

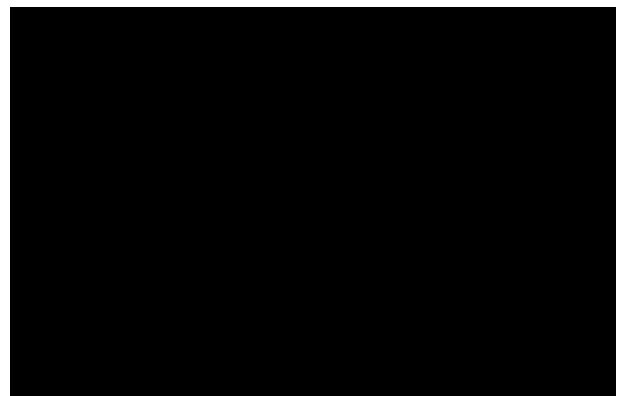

STEELREEF
INFRASTRUCTURE CORP.

SE Saskatchewan Pipelines





Revision History

This Emergency Response Plan is effective March 2021. The company's Emergency Response Program Coordinator is responsible for updating this plan annually or as required. Any errors or omissions in the plan should be brought to their attention.

Date of Issue	Reason For Revision	Section	Affected Pages
June 2024	Annual Update	All	All
December 2023	Add SEEP Pipeline (SK) and Cromer Pipeline (MB)	Foreword	Revision History Distribution List
		Area Specific Information	Update SE Sask. Pipelines Site Section, Map #12067, Hazard Calculations Add: Cromer Pipeline
April 2023	Annual Update	All	All
October 2022	Addition Sinclair CER Pipeline Supplement	Foreword	Revision History Distribution List Table of Contents
		Section 1: Initial Response	External Notification Flowchart
		Section 4: Emergency Response Procedures	Table of Contents Spill Response, Containment & Recovery - All
		Section 5: External Agencies	All
		Area Specific Information	Addition of Sinclair Pipeline Supplement
May 2022	Annual Update	All	All
March 2021	New ERP Manual	All	All

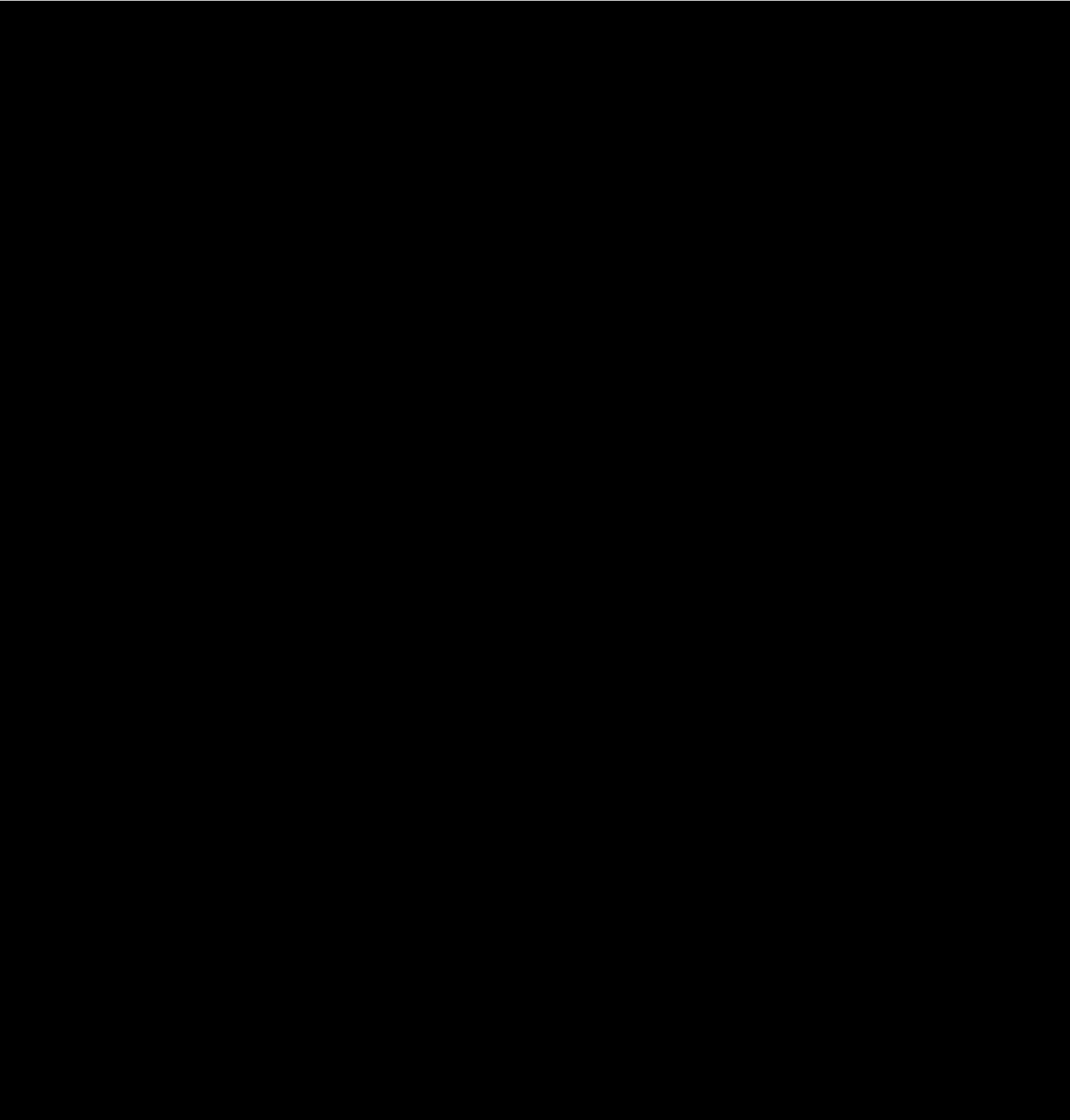

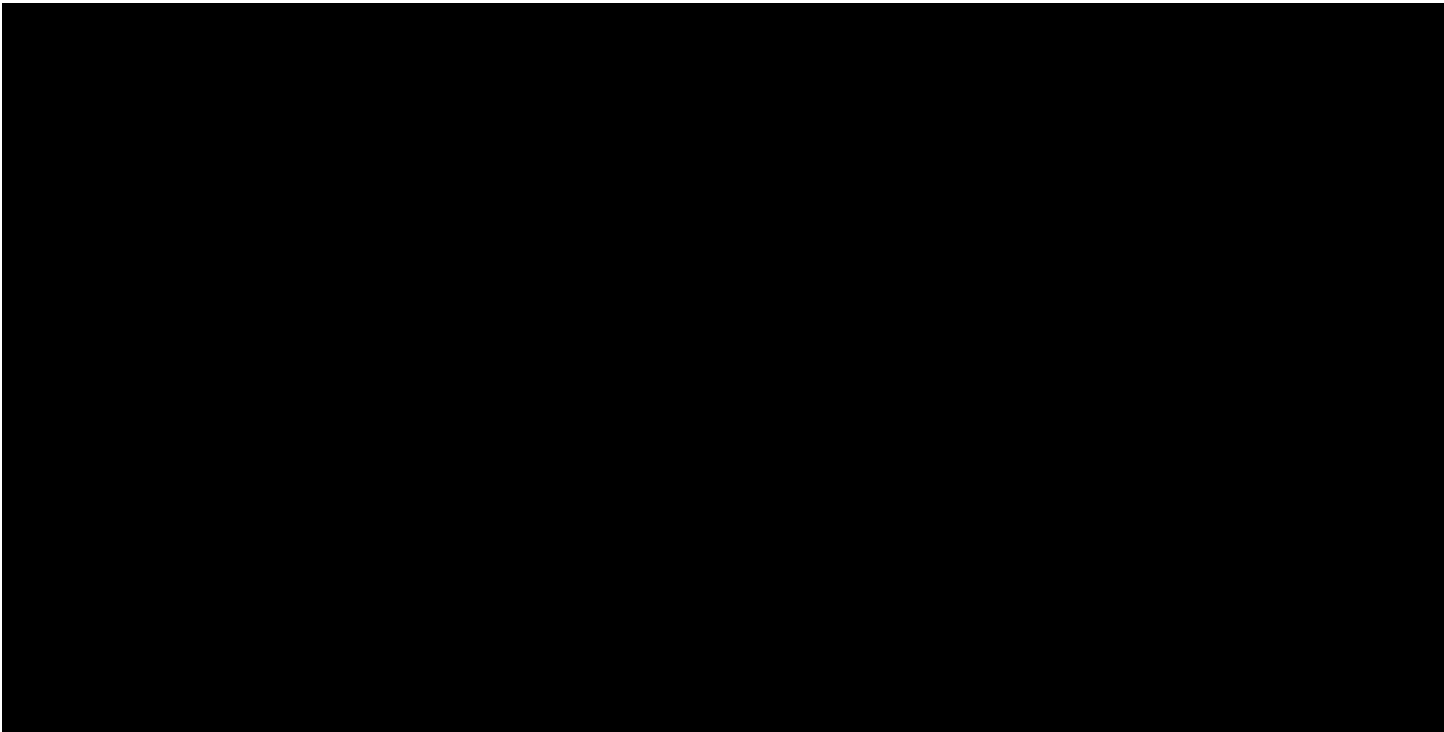

External Manual
15 Digital External Manuals
* CER Digital Copy to be submitted by Steel Reef



Table of Contents

Foreword

Cover Page	
Revision History	1
Distribution List.....	3
Table of Contents.....	5

Section 1: Initial Response

A1 Initial Emergency Report Form	
Five Step Initial Response Guide	
Step 1 - Level of Emergency	
Step 2 - Internal Notification	
Step 3 - External Notification	
Step 4 - Incident Briefing	
Step 5 - Public Safety	

Section 2: Roles and Responsibilities

Field Response Team	
Key Response Personnel	
General Safety Equipment and Resource Lists	
Operator, Truck & Other Safety Equipment	
Response Team Structure	
Quick Reference Guide – Emergency Support Team (EST)	
Field Response Team – Command Staff	
Command Staff Roles Chart	
Field Response Team – General Staff	
Operations Section Roles Chart	
Planning Section Roles Chart	
Logistics Section Roles Chart	
Finance / Admin. Section Roles Chart	
Field Response Team – Public Safety Staff	
Public Safety Staff Roles Chart	
Air Monitors Module	
Reception Centre Rep Module	
Roadblocks Module	
Rovers Module	
Telephoners Module	
Ongoing Response	
Planning “P”	
Five Step Ongoing Response Guide	
Objectives Meeting	



Section 2: Emergency Response Procedures, continued

- Tactics Meeting
- Planning Meeting
- Operations Briefing

Response Team Phone List

Section 3: Communications & Media

Media Relations and Generic Media Statement	1
Generic Media Statement.....	1
Media Management	1
On-Site Media Spokesperson.....	2
Managing the Media On-Site.....	2
Internal Communication	3
Communicating With the Public	3
Information Disseminated to the Public.....	3
Preparing a Preliminary Media Statement	4

Section 4: Emergency Response Procedures

Public Protection Measures	1
Public Protection Measures Flowchart.....	1
Evacuation.....	2
Shelter-in-Place	3
Establishing and Isolating a Perimeter.....	4
Ignition	5
H ₂ S / HVP Ignition Procedure.....	7
Road and Airspace Closures.....	9
Air Monitoring.....	9
Spill Response, Containment and Recovery	1
Spill Response	1
Spill Response Objectives and Strategies.....	1
Control Points	2
Health and Safety.....	4
Initial Site Assessment	4
Safety Briefing.....	4
Initial Site Safety and Hazard Control Plan	4
Western Canadian Spill Services (WCSS).....	5
Provincial Petroleum Release Reporting Requirements Chart.....	7
Containment and Recovery	9
Understanding Environments – Ground and Water	9
Containment of Spilled Product	11
Containment to Recovery Process for Moving Water	15
Recovery of Spilled Product	16
Recovery Techniques.....	17
Spill Control Tactics (Sorbents, Berms, Trench and Bell Hole, Aquadam, Culvert Block, Boom Deployment, and Skimmers / Temporary Storage / Vacuum Units)	



Section 4: Emergency Response Procedures, continued

Post-Incident	1
Call Down Notification.....	1
Public Care and Assistance	1
Clean-up and Repair.....	2
Third Party Investigations.....	2
Review and Debriefing.....	3
Critical Incident Stress Debriefing (CISD).....	3
Post-Incident / Accident Investigation.....	4
Medical Emergencies	1
First Aid Information.....	2
Next-of-Kin Notification	5
Medical Evacuation (MEDEVAC) Procedure	7
Responder Safety	1
Site Safety.....	1
On-Site Work Areas.....	2
Working Alone	4
Missing Persons	6
Rest Periods.....	6
Fire / Explosion	1
Classification of Fires.....	3
Response Actions Based on Type of Fire.....	4
Transportation Incidents	1
First On-Scene Transportation (Road, Rail, Marine) Incident Flowchart.....	1
Loss, Theft or Unlawful Interference Reporting Flowchart.....	2
Motor Vehicle Accidents	3
Emergency Response Assistance Canada (ERAC) plan	4
CANUTEC – Canadian Transport Emergency Centre	4
Dangerous Goods References.....	5
TDG Reportable Quantities.....	5
Rail Car Identification Chart	7
Road Trailer Identification Chart.....	9
Table of Markings, Labels and Placards.....	11
TDG 30 Day Follow-up Report Form.....	13
Weather and Natural Disasters	1
Earthquake	2
Floods	4
Thunderstorm and Lightning Safety	6
Tornados.....	7
Winter Storms: Blizzards, Freezing Rain, Heavy Snow, Blowing Snow	7
After a Disaster.....	9
Security Incidents	1
Responding to Threats.....	1
Bomb Threats.....	2
Suspicious Packages.....	5



Section 4: Emergency Response Procedures, continued

Trespassing	7
Vandalism	8
Terrorism	8
Cyber-Attacks	9
Security Management Program	
Animal Encounters	1
First Responders to Animal Attacks	1
Bears	2
Cougars	4
Large Hooved Animals (Ungulates)	6
Rattle Snakes	7
Wolves	8
Bees and Wasps	9
EpiPens	10

Section 5: External Agencies

SK Provincial Notification Matrix	
MB Provincial Notification Matrix	
ND State Notification Matrix	
SK Provincial Lead Agency Roles	
MB Provincial Lead Agency Roles	
ND State Agency Roles	
Government Consultation Summary	
Specific Government Agency Roles	
Health Services	
Local Authority	
SK Provincial Supporting Agency Roles	
MB Provincial Supporting Agency Roles	
Canada Federal Agency Roles	
US Federal Agency Roles	

Section 6: Forms

Documentation During and After an Incident

Form Descriptions

Incident Command System (ICS) Forms

ICS 201 Incident Briefing	
ICS 202 Incident Objectives	
ICS 203 Organization Assignment List	
ICS 204 Assignment List	
ICS 207 Incident Organization Chart	
ICS 208 Safety Message / Plan	
ICS 209 Incident Status Summary	
ICS 211 Check-In / Out List	
ICS 214 Activity Log	
ICS 215 Operational Planning Worksheet	



Section 6: Forms, continued

- ICS 215A IAP Safety Analysis
- ICS 221 Demobilization Checkout
- ICS 230 Meeting Schedule
- ICS 231 Meeting Summary
- ICS 233 Incident Open Action Tracker

Emergency Forms

- A1 Initial Emergency Report Form
- A2 Odour Complaint Script
- A3 Regulatory First Call Communication
- A4 Incident Action Plan (IAP) Checklist
- A5 Air Monitoring Log
- A6 Threatening Call / Bomb Threat
- A7 STARS Landing Zone Card

Resident Forms

- B1 Reception Centre Registration Log
- B2 Resident Compensation Log
- B3 Resident Contact Log
- B4 Roadblock Log
- B5 Evacuation Notice
- B6 Early Notification / Voluntary Evacuation Phone Message
- B7 Shelter-In-Place Phone Message
- B8 Evacuation Phone Message

Media Forms

- C1 Preliminary Media Statement
- C2 Media Contact Log
- C3 Government Agency Contact Log
- C4 Media Centre Site

Appendices

Appendix A: ERP Scope, Training and Plan Maintenance	1
Scope	1
Plan Objectives.....	1
Purpose	1
HSE Policy	3
Training Requirements.....	5
Plan Maintenance	6
Appendix B: Incident Command Post (ICP)	9
Communication Methods Between Command Posts – Saskatchewan.....	9
ICP Activation and Setup.....	10
Appendix C: Toxic Gases.....	12
Hydrogen Sulphide (H ₂ S).....	12
Sulphur Dioxide (SO ₂).....	18



Appendices, continued

Appendix D: Key Elements of the Incident Command System (ICS)	23
Management by Objectives	23
Unity and Chain of Command	23
Organizational Flexibility	24
Span of Control	24
Common Terminology	24
Incident Action Plan (IAP)	24
Integrated Communications	24
Establishment and Transfer of Command	25
Resources Management	25
Summary of Responsibilities	25
Appendix E: Land Descriptions	26
Dominion Land Survey (DLS) System	26
National Topographic System (NTS)	27
Appendix F: ERP Reference Material	28
Acronyms	28
Glossary of Terms	29



Section 1: Initial Response

A1 Initial Emergency Report Form

Five Step Initial Response Guide

Step 1 – Level of Emergency

Step 2 – Internal Notification

Step 3 – External Notification

Step 4 – Incident Briefing

Step 5 – Public Safety



A1 Initial Emergency Report Form



First On-Scene Actions

Evacuate	<input type="checkbox"/> Get to a safe area immediately. <input type="checkbox"/> Move upwind if release is downwind of you. <input type="checkbox"/> Move crosswind if a release is upwind from you. <input type="checkbox"/> Move to higher ground if possible.
Alarm	<input type="checkbox"/> Call for help ("Man Down"). <input type="checkbox"/> Sound bell, horn or whistle, or call by radio. <input type="checkbox"/> For medical emergencies, call 911.
Assess	<input type="checkbox"/> Take head count, locate any casualties. Consider all of the hazards. <input type="checkbox"/> Fill out information below to complete assessment.
Protect	<input type="checkbox"/> Put on breathing apparatus before attempting rescue.
Rescue	<input type="checkbox"/> Remove any casualties to a safe area.
First Aid	<input type="checkbox"/> Follow the standard first aid protocols at worksite. (CPR, etc.)
Medical Aid	<input type="checkbox"/> Arrange transport of casualties to medical aid. <input type="checkbox"/> Provide information to Emergency Medical Services (EMS).

Incident Details <i>To be completed by the person involved or notified</i>	
Report taken by	Date / Time
Name of person calling	Caller Telephone
Incident Location <div style="text-align: center;">(LSD / NTS)</div>	
Event Summary	
Agencies Notified	<input type="checkbox"/> Yes Who? <input type="checkbox"/> No
Event Status	<input type="checkbox"/> Incident contained or controlled <input type="checkbox"/> Intermittent control possible <input type="checkbox"/> Imminent control possible <input type="checkbox"/> Incident is uncontrolled
Site Type	<input type="checkbox"/> Well <input type="checkbox"/> Pipeline <input type="checkbox"/> Tank Farm/Storage <input type="checkbox"/> Battery/Plant/Facility <input type="checkbox"/> Other _____
Incident Type	<input type="checkbox"/> Sour Gas Release <input type="checkbox"/> Sweet Gas Release <input type="checkbox"/> Pipeline Break <input type="checkbox"/> Security (theft, threat, terrorism) <input type="checkbox"/> Loss of Containment <input type="checkbox"/> Fire/Explosion <input type="checkbox"/> Worker Injury/Fatality <input type="checkbox"/> Vehicle/Transportation <input type="checkbox"/> Liquid Spill <input type="checkbox"/> Other _____

A1 Initial Emergency Report Form



Impacts			
Public Health and Safety	<input type="checkbox"/> Could be jeopardized <input type="checkbox"/> Is jeopardized		
Public Protection Measures Taken	<input type="checkbox"/> Notification <input type="checkbox"/> Evacuation <input type="checkbox"/> Shelter-in-place <input type="checkbox"/> Roadblocks		
Worker Injuries	<input type="checkbox"/> First Aid <input type="checkbox"/> Hospitalized <input type="checkbox"/> Fatality <input type="checkbox"/> Other _____		
Distance to nearest surface development	_____ km	Distance to nearest urban centre _____ km	
Details			
Release Impact	<input type="checkbox"/> On-Lease <input type="checkbox"/> Off-Lease Product _____		Amount _____
Gas Readings	H ₂ S _____ SO ₂ _____ LEL _____ Other _____		
Distance to nearest watercourse	_____ km	Weather Conditions	
Details			
Media Involvement?	<input type="checkbox"/> Yes <input type="checkbox"/> No	Regulator Involvement?	<input type="checkbox"/> Yes <input type="checkbox"/> No
		Public Affairs/Community Relations Issues?	<input type="checkbox"/> Yes <input type="checkbox"/> No
Details			
Notes / Instructions Provided:			

Distribute this completed report to all Key Response Personnel

Note: Ensure the First On-Scene Actions have been completed before proceeding to the Five Step Initial Response Guide.

First On-Scene Actions

- Evacuate
- Alarm
- Assess
- Protect
- Rescue
- First Aid
- Medical Aid
- Refer to A1 Initial Emergency Report Form

Step 1 - Level of Emergency

Determine Level of Emergency:

- Alert / Minor
- Level 1 Emergency
- Level 2 Emergency
- Level 3 Emergency

Use the following resources:

- Section 1: Initial Response (Level of Emergency)
- The Emergency Assessment SmartPhone App. (Search H2Safety or Emergency Assessment in the App Store).



Note: The BCER and the AER state that the licensee must use either the Incident Classification Matrix (BC) or the Assessment Matrix for Classifying Incidents (AB) to determine the Level of Emergency. If the incident overlaps more than one level, always choose the highest level.

Step 2 - Internal Notification

- Follow the Internal Emergency Notification Flowchart to determine who needs to be notified.
- Relay the information in the completed A1 Initial Emergency Report Form.
- Mobilize internal resources to the site, to the Incident Command Post (ICP), to the Corporate Emergency Operations Centre (CEOC), or place them on standby as required.

Use the following resources:

- Section 1: Initial Response (Internal Emergency Notification Flowchart)
- Section 3: Roles & Responsibilities (Response Team Phone List)
- Section 6: Forms (A1)
- Initiate an H2CommandCentre session.

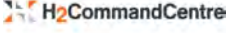

Step 3 - External Notification

- Follow the External Emergency Notification Flowchart to determine which external agencies need to be notified.
 - 911 (police, fire, ambulance)
 - Health Authority / Health Services
 - Regulatory agency to confirm the Level of Emergency
 - Air Monitoring (at all levels of emergency)
 - Local Authority (Cities, Towns, Villages, Counties, M.D.s, R.D.s, R.M.s, Special Areas, Reserves, etc.)
- Use the following resources:
 - Section 1: Initial Response (External Emergency Notification Flowchart)
 - Section 5: External Agencies (Provincial Notification Matrix)
 - Area Specific Information (White tabs)

Step 4 - Incident Briefing

Complete an ICS 201 Incident Briefing Form:

- Define incident details and an operational period (page 1).
 - Establish the On-Site Command Post (OSCP) and ICP.
- Document current incident objectives, strategies and tactics (page 2).
- Prioritize objectives (page 2).
- Define initial Incident Command Structure (page 3).
- Identify required resources and when they'll be available (page 4).

Use the following resources:

- Section 1: Initial Response (ICS 201)
- Section 6: Forms (ICS 201)

Step 5 - Initiate Public Safety

<p>Public Protection Measures</p> <ul style="list-style-type: none"> Determine the hazard area; start with Emergency Planning Zone (EPZ) as default. Identify the affected surface developments and area users. (Houses, businesses, guides/outfitters, trappers, schools, other oil and gas operators, etc.) Determine the appropriate public protection measure for the affected surface developments and area users. (Evacuation, shelter-in-place and/or ignition) Coordinate evacuation outside of the EPZ with the local authority, if required. Utilize broadcast media to notify public outside of the EPZ in immediate evacuation situations. <p>Use the following resources:</p> <ul style="list-style-type: none"> Section 1: Initial Response (Public Protection Measures Flowchart) Section 2: Emergency Response Procedures (Public Protection Measures) Area Specific Information (Map / EPZ calculation tables) 	<p>Rovers</p> <ul style="list-style-type: none"> Dispatch Rovers to patrol the EPZ. Follow safety procedures and have appropriate PPE. Search the EPZ for transients. Assist residences that require evacuation assistance. Investigate surface developments that are identified as vacant or those who were unable to contact. Post notices on all outside doors of empty surface developments, vehicles, etc. Record all contacts, communications and monitoring readings using the following forms: ICS 214, A5, B3 & B5. Monitor and record air quality readings using the following forms: ICS 214 & A5. (Smoke, plumes, wind, etc.) Provide status updates to the Public Safety Group Supervisor at established intervals; utilize H2CommandCentre if available. <p>Use the following resources:</p> <ul style="list-style-type: none"> Section 3: Roles & Responsibilities (Rovers) Section 6: Forms Area Specific Information (Map) 	<p>Telephoners</p> <ul style="list-style-type: none"> Establish a Telephoner Team to notify residents to evacuate or shelter-in-place as required. Notify special needs residents at a Level 1 Emergency and provide the option to evacuate voluntarily. Follow-up phone calls to address resident inquiries. Record all phone calls and communications using the following forms: ICS 214, B3, B6, B7, & B8. Provide status updates to the Public Safety Group Supervisor at established intervals; utilize H2CommandCentre if available. <p>Use the following resources:</p> <ul style="list-style-type: none"> Section 3: Roles & Responsibilities (Telephoners) Section 6: Forms
<p>Roadblocks</p> <ul style="list-style-type: none"> Follow safety procedures to safely establish roadblocks wherever a road intersects with the EPZ and advise vehicles to reroute. Record all vehicle encounters and air monitoring readings. Complete the following forms: ICS 214, A5, B3 & B4. Gain permission from the Public Safety Group Supervisor for response vehicles to enter the hazard area. Provide status updates to the Public Safety Group Supervisor at established intervals; utilize H2CommandCentre if available. <p>Use the following resources:</p> <ul style="list-style-type: none"> Section 3: Roles & Responsibilities (Roadblocks) Section 6: Forms Area Specific Information (Map) 	<p>Air Monitors</p> <ul style="list-style-type: none"> Dispatch Air Monitoring personnel to the nearest residence / public facility downwind of the incident. Follow safety procedures and have appropriate PPE. Monitor and record air quality readings using the following forms: ICS 214 & A5. (Smoke, plumes, wind, etc.) Provide status updates to the Public Safety Group Supervisor at established intervals; utilize H2CommandCentre if available. <p>Use the following resources:</p> <ul style="list-style-type: none"> Section 3: Roles & Responsibilities (Air Monitors) Section 6: Forms 	<p>Reception Centre Rep</p> <ul style="list-style-type: none"> If residents are evacuated, dispatch a Reception Centre Representative to the reception centre location. Meet and register evacuated residents. Record contact information for those who choose to stay elsewhere. Complete the following forms: ICS 214, B1, B2 & C2. Regularly provide status updates to the Public Safety Group Supervisor (those who have arrived and those who have not yet arrived); utilize H2CommandCentre if available. <p>Use the following resources:</p> <ul style="list-style-type: none"> Section 3: Roles & Responsibilities (Reception Centre Rep) Section 6: Forms

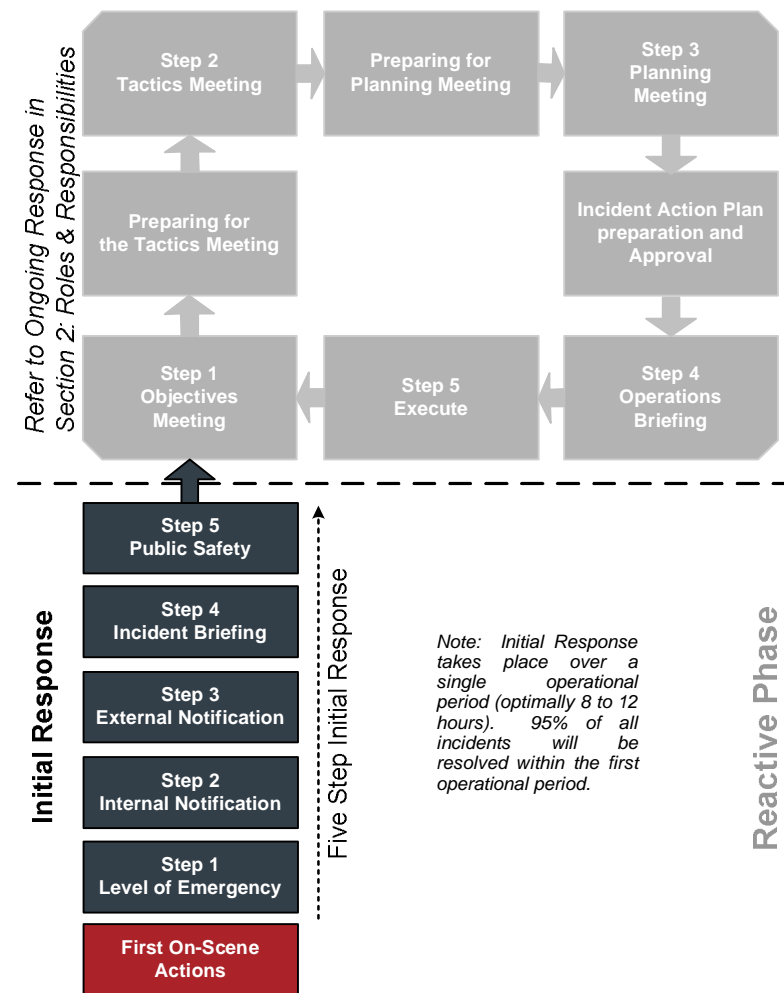

Five Step Initial Response Guide



Step 1 – Level of Emergency



Assessment Matrix for Classifying Incidents

Follow these 3 steps to determine the Level of Emergency

Step 1		Table 1 – Consequence of Incident
Rank	Category	Example of Consequence in Category
1	Minor	<input type="checkbox"/> No worker injuries. <input type="checkbox"/> Nil or low media interest. <input type="checkbox"/> Liquid release contained on lease. <input type="checkbox"/> Gas release impact on lease only.
2	Moderate	<input type="checkbox"/> First Aid treatment required for on-site worker(s). <input type="checkbox"/> Local and possible regional media interest. <input type="checkbox"/> Liquid release not contained on lease. <input type="checkbox"/> Gas release impact has potential to extend beyond site.
3	Major	<input type="checkbox"/> Worker(s) requires hospitalization. <input type="checkbox"/> Regional and national media interest. <input type="checkbox"/> Liquid release extends beyond lease – not contained. <input type="checkbox"/> Gas release impact extends beyond lease – public health / safety could be jeopardized.
4	Catastrophic	<input type="checkbox"/> Fatality. <input type="checkbox"/> National and international media interest. <input type="checkbox"/> Liquid release off lease not contained – potential for, or is, affecting water or sensitive terrain. <input type="checkbox"/> Gas release impact extends beyond lease – public health / safety jeopardized.

Under “Example of Consequence in Category” column, select the box with the worst consequence that currently fits the incident. For example, if there is a fatality on site you must select the “Catastrophic” category which would give you a “Rank” of 4.

Step 2		Table 2 – Likelihood of Incident Escalating *
Rank	Descriptor	Example of Consequence in Category
1	Unlikely	The incident is contained or controlled, and is unlikely to escalate. There is no chance of additional hazards. Ongoing monitoring required.
2	Moderate	Control of the incident may have deteriorated but imminent control of the hazard by the duty holder is probable. It is unlikely that the incident will escalate.
3	Likely	Imminent or intermittent control of the incident is possible. The duty holder has the capability of using internal and external resources to manage and bring the hazard under control in the near term.
4	Almost Certain or Currently Occurring	The incident is uncontrolled and there is little chance that the duty holder will be able to bring the hazard under control in the near term. The duty holder will require assistance from outside parties to remedy the situation.

* What is the likelihood that the incident will escalate, resulting in an increased exposure to public health, safety, or the environment?

Sum the “Rank” from Table 1 and Table 2 to obtain the Risk Level and the Incident Classification

Combine the two rankings from the above tables to obtain the “Risk Level” and “Level of Emergency”.

For example, if the “Consequence Rank” is 4 and the “Likelihood Rank” is 1 then the combined score or “Risk Level” is 5.

A “Risk Level” of 5 would be classified as a Level 1 Emergency.

Refer to the appropriate column in Table 4 (reverse of this page) for responses to the Level of Emergency that has been determined.

Note:

- In Alberta, the duty holder **must** use the Assessment Matrix for Classifying Incidents to classify an incident.
- In Alberta, the duty holder **must** contact the Alberta Energy Regulator (AER) after it has communicated and activated internal response resources to confirm the level of emergency and convey the specifics of the incident.
- After contacting the Alberta Energy Regulator (AER), the duty holder in Alberta, must notify the local authority, the RCMP/police and the local health authority if the hazardous release goes off lease and has the potential to impact the public or if the duty holder has contacted members of the public or the media.
- Once the situation improves, the duty holder must make the decision to downgrade or stand down an emergency in consultation with the government regulator.

Step 3	Table 3 – Incident Classification
Risk Level	Assessment Results
Very Low 2 – 3	Alert
Low 4 – 5	Level – 1 Emergency
Medium 6	Level – 2 Emergency
High 7 – 8	Level – 3 Emergency

The H₂Safety Services Inc. Emergency Assessment Smart Phone app is the preferred method for determining the level of emergency. Search H₂Safety or Emergency Assessment in the Apple or Android app store.



Step 1 – Level of Emergency







Step 4		Table 4 – Incident Response – Incident Classification		
Responses	Alert	Level – 1 Emergency	Level – 2 Emergency	Level – 3 Emergency
Communications				
Internal	Discretionary, depending on the duty holder policy.	Notification of off-site management.	Notification of off-site management.	Notification of off-site management.
Public	Courtesy, at duty holder's discretion.	Mandatory for individuals in the EPZ who have requested notification.	Planned and instructive in accordance with the specific ERP.	Planned and instructive in accordance with the specific ERP.
Media	Reactive	Reactive, as required.	Proactive media management to local or regional interest.	Proactive media management to national interest.
Government	Reactive. Notify AER if public or media is contacted.	Notify local AER field centre. Call local authority and health authority if public or media is contacted.	Notify local AER field centre, local authority & health authority.	Notify local AER field centre, local authority & health authority.
Actions				
Internal	On site, as required by duty holder.	On site, as required by the duty holder. Initial response is in accordance with the AER-approved ERP or corporate ERP.	Predetermined public safety actions are under way. Corporate management team alerted and may be engaged to support on-scene responders.	Full implementation of incident command system.
External	On site, as required by the duty holder.	On site, as required by the duty holder.	Potential for multiagency response (i.e., operator, municipal, provincial, federal).	Immediate multiagency response (i.e., operator, municipal, provincial, federal).
Resources				
Internal	Immediate and local. No additional personnel required.	Establish what resources are required.	Limited supplemental resources or personnel are required.	Significant resources are required.
External	None.	Begin to establish resources that may be required.	Possible assistance from government agencies and external support services.	Assistance from government agencies and external support services are required.

Responses	Alert	Level – 1 Emergency	Level – 2 Emergency	Level – 3 Emergency
Definition	An incident that can be handled on site by the duty holder through normal operating procedures and is deemed a very low risk to the public.	The incident presents no danger outside the duty holder's property or threat to the public and has a minimal environmental impact. Duty-holder personnel can manage the incident themselves with immediate control of the hazard. There is little or no media interest.	The incident presents no immediate danger outside the duty holder's property but could potentially extend beyond the duty holder's property. Outside agencies must be notified. Imminent control of the hazard is probable, but there is a moderate threat to the public or the environment or both. There may be local and regional media interest in the event.	The safety of the public is in jeopardy from a major uncontrolled hazard. There are likely significant and ongoing environmental impacts. Immediate multiagency municipal and provincial government involvement is required.
Responses	Investigate and escalate level if required initiate control procedures	In addition to Alert level responses: <ul style="list-style-type: none"> - Isolate the hazard area - Activate the ERP - Conduct public safety actions for special needs residents - If special needs residents decide to voluntarily evacuate, activate a reception centre - Notify appropriate internal personnel and government agencies - Have air monitoring conducted at the site if necessary 	In addition to Level-1 responses: <ul style="list-style-type: none"> - Fully activate emergency response procedures with command centres established or on standby - Inform government agencies of situation and incorporate support (government regulator, local authority, health authority, RCMP) - Identify the hazard and emergency operating areas and take any required action to protect the public through shelter or evacuation. - Prepare ignition team (butane gas related) - Respond to media, company and public questions - Prepare for the potential of the situation to escalate to a Level-3 - Record activities and keep government and municipal agencies advised, if applicable - Establish roadblocks - Activate the EOC, if it has not already been established at a Level-1 emergency 	In addition to Level-2 responses: <ul style="list-style-type: none"> - Emergency response plan and command centres are fully activated - Company Management has been notified and all internal support positions staffed - Continue to monitor and adjust hazard and emergency operating areas (maintain security) - Mobilize additional people and resources - Ignite a gas release if ignition criteria are met - Continue to advise company and government - Activate the reception centre, if it has not already been established at a Level-1 or Level-2 emergency - Continue to maintain the EOC, once it is activated

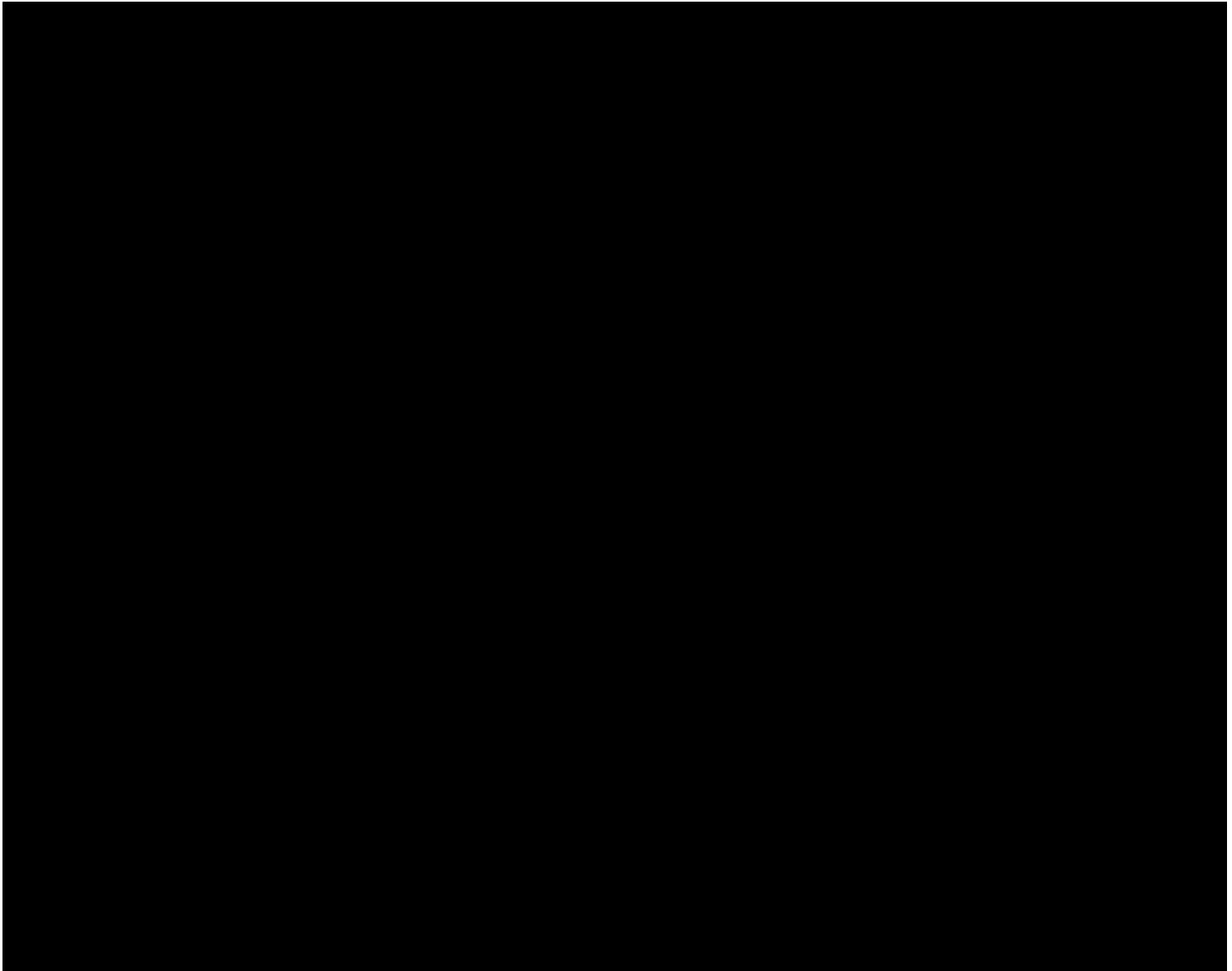

Internal Emergency Notification Flowchart



- | | |
|---|-----------------------|
|  | Steel Reef |
|  | External Notification |
|  | External Agencies |

Note: After Initial Notifications are complete, please reference Step 4 – Incident Briefing and begin building the initial Organizational Structure (pg 3) within the ICS 201 Incident Briefing form.

Step 3 – External Notification



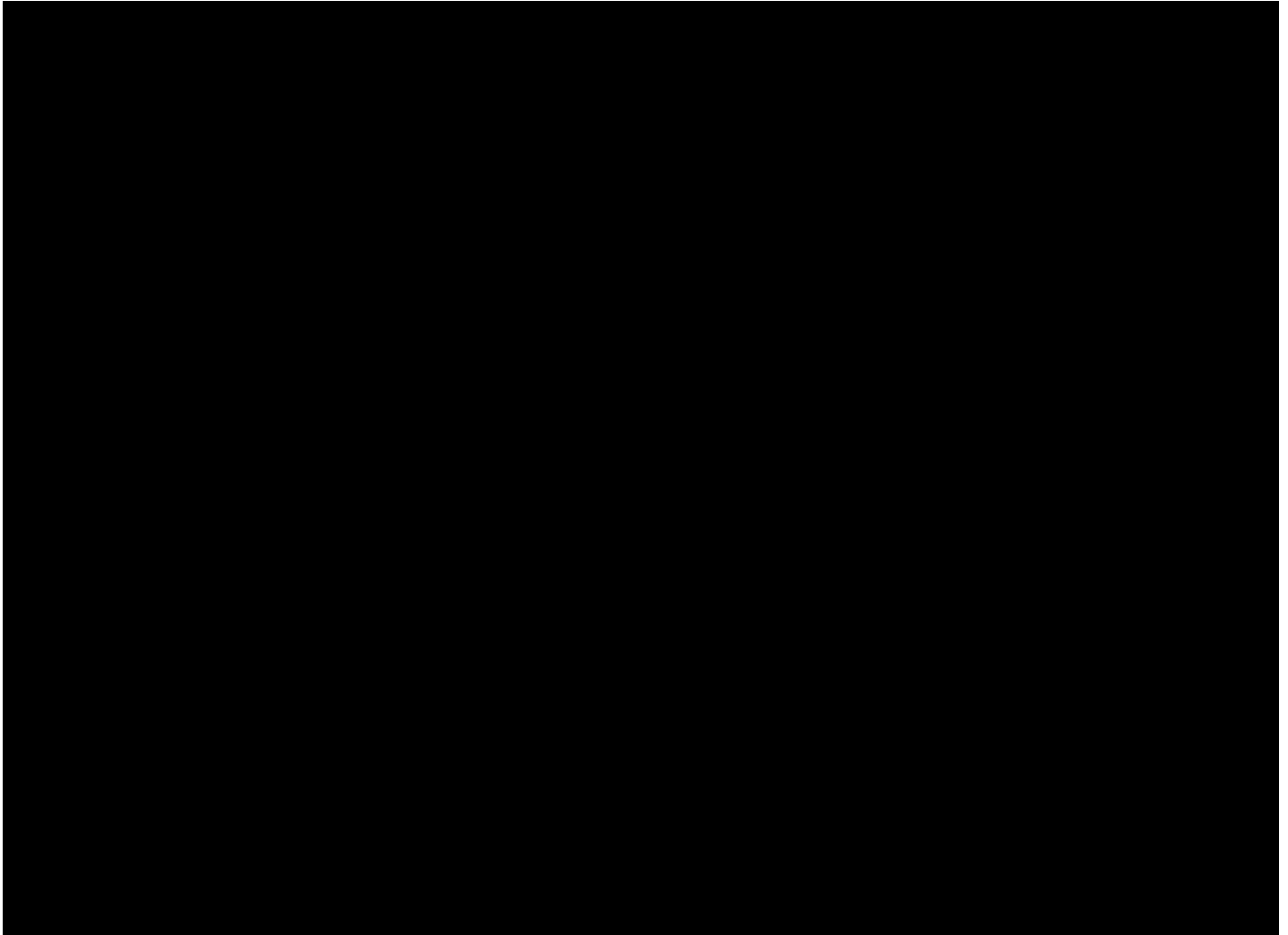

External Emergency Notification Flowchart

Prior to commencing contact of the agencies below, make sure a completed A1 Initial Emergency Report Form is available and at hand for reference.



Refer to Section 5: External Agencies for the Government Notification Matrix, Provincial Lead and Supporting Agencies and Federal Agencies required to be contacted or notified.

-  Steel Reef
-  External Notification
-  External Agencies

Note: After Initial Notifications are complete, please reference Step 4 – Incident Briefing and begin building the initial Organizational Structure (pg 3) within the ICS 201 Incident Briefing form.

Step 4 – Incident Briefing



Incident Name:				
Date/Time Initiated:				
Prepared By:			ICS Position:	
Level of Emergency	Alert / Minor	Level 1	Level 2	Level 3
Map Sketch:				
<i>Note: Maps can be drawn or attached here.</i>				
Situation Summary: (Write description or attach A1)				
Safety Briefing:				

Step 4 – Incident Briefing



Current and Planned Objectives:	
Priorities: (1) Life Safety (2) Incident Stabilization (3) Environment & Property	
1. Ensure Safety of Citizens and Response Personnel:	4. Minimize Economic Impacts:
<input type="checkbox"/> 1a. Identify hazard(s) of released product.	<input type="checkbox"/> 4a. Consider tourism and local economic impacts.
<input type="checkbox"/> 1b. Establish site control (hot zone, warm zone, cold zone, & security).	<input type="checkbox"/> 4b. Protect public and private assets, as resources permit.
<input type="checkbox"/> 1c. Establish an Emergency Response Zone and Initiate Public Safety Actions.	<input type="checkbox"/> 4c. Establish damage claims process.
<input type="checkbox"/> 1d. Consider evacuations if needed.	5. Keep Stakeholders and Public Informed of Response Activities:
<input type="checkbox"/> 1e. Establish aircraft restrictions.	<input type="checkbox"/> 5a. Provide forum to obtain stakeholder input and concerns.
<input type="checkbox"/> 1f. Monitor air in impacted areas	<input type="checkbox"/> 5b. Provide stakeholders with details of response actions.
<input type="checkbox"/> 1g. Develop site safety plan for personnel and ensure safety briefings are conducted.	<input type="checkbox"/> 5c. Identify stakeholder concerns and issues, and address as practical.
2. Control the Source of the Release:	<input type="checkbox"/> 5d. Provide timely safety announcements.
<input type="checkbox"/> 2a. Complete emergency shutdown.	<input type="checkbox"/> 5e. Conduct regular news briefings.
<input type="checkbox"/> 2b. Conduct firefighting.	<input type="checkbox"/> 5f. Conduct public meetings, as appropriate.
<input type="checkbox"/> 2c. Initiate temporary repairs.	
3. Manage a Coordinated Response Effort:	
<input type="checkbox"/> 3a. Complete or confirm notifications.	
<input type="checkbox"/> 3b. Establish a unified command organization and facilities (command post, etc.).	
<input type="checkbox"/> 3c. Ensure mobilization and tracking of resources and account for personnel and equipment.	
<input type="checkbox"/> 3d. Complete documentation.	
Current and Planned Actions, Strategies and Tactics:	
Time:	Actions:
HHMM	
HHMM	
HHMM	
HHMM	
HHMM	
HHMM	
HHMM	
HHMM	
HHMM	

Step 4 – Incident Briefing



*** This is a condensed Organizational Chart to account for all currently responding personnel during the Initial Response.**

```

graph TD
    IC[Incident Commander] --- IO[Information Officer]
    IC --- LO[Liaison Officer]
    IC --- SO[Safety Officer]
    IC --- OSGS[On-Site Group Supervisor]
    IC --- PSGS[Public Safety Group Supervisor]
    IC --- DOC[Documentation]
    
    OSGS --- SS[Site Safety]
    OSGS --- C[Control]
    OSGS --- CO[Containment]
    OSGS --- O1[Other]
    OSGS --- O2[Other]
    OSGS --- O3[Other]
    
    PSGS --- AM[Air Monitors]
    PSGS --- RB[Roadblocks]
    PSGS --- R[Rovers]
    PSGS --- T[Telephoners]
    PSGS --- RCR[Reception Centre Representative]
    PSGS --- O4[Other]
  
```

Incident Commander
Name _____
Number _____

Information Officer
Name _____
Number _____

Liaison Officer
Name _____
Number _____

Safety Officer
Name _____
Number _____

On-Site Group Supervisor
Name _____
Number _____

Public Safety Group Supervisor
Name _____
Number _____

Documentation
Name _____
Number _____

Site Safety
Name _____
Number _____

Control
Name _____
Number _____

Containment
Name _____
Number _____

Other
Name _____
Number _____

Other
Name _____
Number _____

Other
Name _____
Number _____

Air Monitors
Name _____
Number _____

Roadblocks
Name _____
Number _____

Rovers
Name _____
Number _____

Telephoners
Name _____
Number _____

Reception Centre Representative
Name _____
Number _____

Other
Name _____
Number _____

Note: Refer to ICS 207 Incident Organization Chart in Section 6: Forms (Blue Tab) for full command structure.

Resources Summary:

Step 4 – Incident Briefing



Resources Summary:				
Resource(s)	Time Called	ETA	On-Site	Notes (Location/Assignment/Status)
			<input type="checkbox"/>	
			<input type="checkbox"/>	
			<input type="checkbox"/>	
			<input type="checkbox"/>	
			<input type="checkbox"/>	
			<input type="checkbox"/>	
			<input type="checkbox"/>	
			<input type="checkbox"/>	
			<input type="checkbox"/>	
			<input type="checkbox"/>	
			<input type="checkbox"/>	
			<input type="checkbox"/>	
			<input type="checkbox"/>	
			<input type="checkbox"/>	
			<input type="checkbox"/>	
			<input type="checkbox"/>	
			<input type="checkbox"/>	
			<input type="checkbox"/>	
			<input type="checkbox"/>	
			<input type="checkbox"/>	
			<input type="checkbox"/>	
			<input type="checkbox"/>	
External Notifications: (Government)				
Agency	Time Called	Notes		

Step 4 – Incident Briefing



Site Safety and Hazard Control Analysis	
Site Control	
1. Is Site Control set-up? <input type="checkbox"/> Yes <input type="checkbox"/> No	2. Is there an On-Scene Command Post? <input type="checkbox"/> Yes <input type="checkbox"/> No If so, where?
3. Have all personnel been accounted for? <input type="checkbox"/> Yes <input type="checkbox"/> No <input type="checkbox"/> Don't Know	Injuries: Unaccounted: Fatalities: Trapped:
4. Are observers involved or rescue attempts planned? Observers: <input type="checkbox"/> Yes <input type="checkbox"/> No Rescuers: <input type="checkbox"/> Yes <input type="checkbox"/> No	5. Are Decontamination areas setup? <input type="checkbox"/> Yes <input type="checkbox"/> No If so, where?
Hazard Identification, immediate signs of: (if yes, explain in remarks)	
1. Electrical line(s) down or overhead? <input type="checkbox"/> Yes <input type="checkbox"/> No	2. Unidentified liquid or solid products visible? <input type="checkbox"/> Yes <input type="checkbox"/> No
3. Wind direction across incident: <input type="checkbox"/> Towards your position Wind Speed: <input type="checkbox"/> Away from your position	4. Is a safe approach possible? <input type="checkbox"/> Yes <input type="checkbox"/> No
5. Odours or smells? <input type="checkbox"/> Yes <input type="checkbox"/> No	6. Vapours visible? <input type="checkbox"/> Yes <input type="checkbox"/> No
7. Holes, ditches, fast water, cliffs, etc. nearby? <input type="checkbox"/> Yes <input type="checkbox"/> No	8. Fire, sparks, sources of ignition nearby? <input type="checkbox"/> Yes <input type="checkbox"/> No
9. Is local traffic a potential problem? <input type="checkbox"/> Yes <input type="checkbox"/> No	10. Product placards, colour codes visible? <input type="checkbox"/> Yes <input type="checkbox"/> No
11. Other Hazards? <input type="checkbox"/> Yes <input type="checkbox"/> No	12. As you approach the scene from the upwind side, do you note a change in the status of any of the above? <input type="checkbox"/> Yes <input type="checkbox"/> No
13. Remarks:	
Hazard Mitigation: have you determined the necessity for any of the following?	
1. Entry Objectives:	
2. Warning sign(s), barriers, colour codes in place? <input type="checkbox"/> Yes <input type="checkbox"/> No	
3. Hazardous material being monitored? <input type="checkbox"/> Yes <input type="checkbox"/> No 3a. Sampling equipment: 3b. Sampling location(s): 3c. Sampling frequency: 3d. Peak reading: 3e. Personal exposure monitoring:	
4. Protective gear / level: 4b. Respirators 4d. Boots:	4a. Gloves: 4c. Clothing: 4e. Chemical cartridge change frequency:
5. Decontamination 5a. Instructions: 5b. Decontamination equipment and materials:	
6. Emergency escape route established? <input type="checkbox"/> Yes <input type="checkbox"/> No Route?	
7. Field responders briefed on hazards? <input type="checkbox"/> Yes <input type="checkbox"/> No	
8. Remarks:	
Protective Zones: record initial control perimeters (see Figure 1)	

Step 4 – Incident Briefing



<p style="text-align: center;">Figure 1 Protective Zones</p>	<p>1. Is there a Hot Zone established? <input type="checkbox"/> Yes <input type="checkbox"/> No If so, Where?</p>
	<p>2. Is there a Warm Zone established? <input type="checkbox"/> Yes <input type="checkbox"/> No If so, Where?</p>
	<p>3. Is there a Cold Zone established? <input type="checkbox"/> Yes <input type="checkbox"/> No If so, Where?</p>
	<p>4. Remarks: (Include any information on evacuation route, etc.)</p>
<p>5. Include any site sketches or photos of the protective zones (if available):</p>	



Public Protection Measures Flowchart

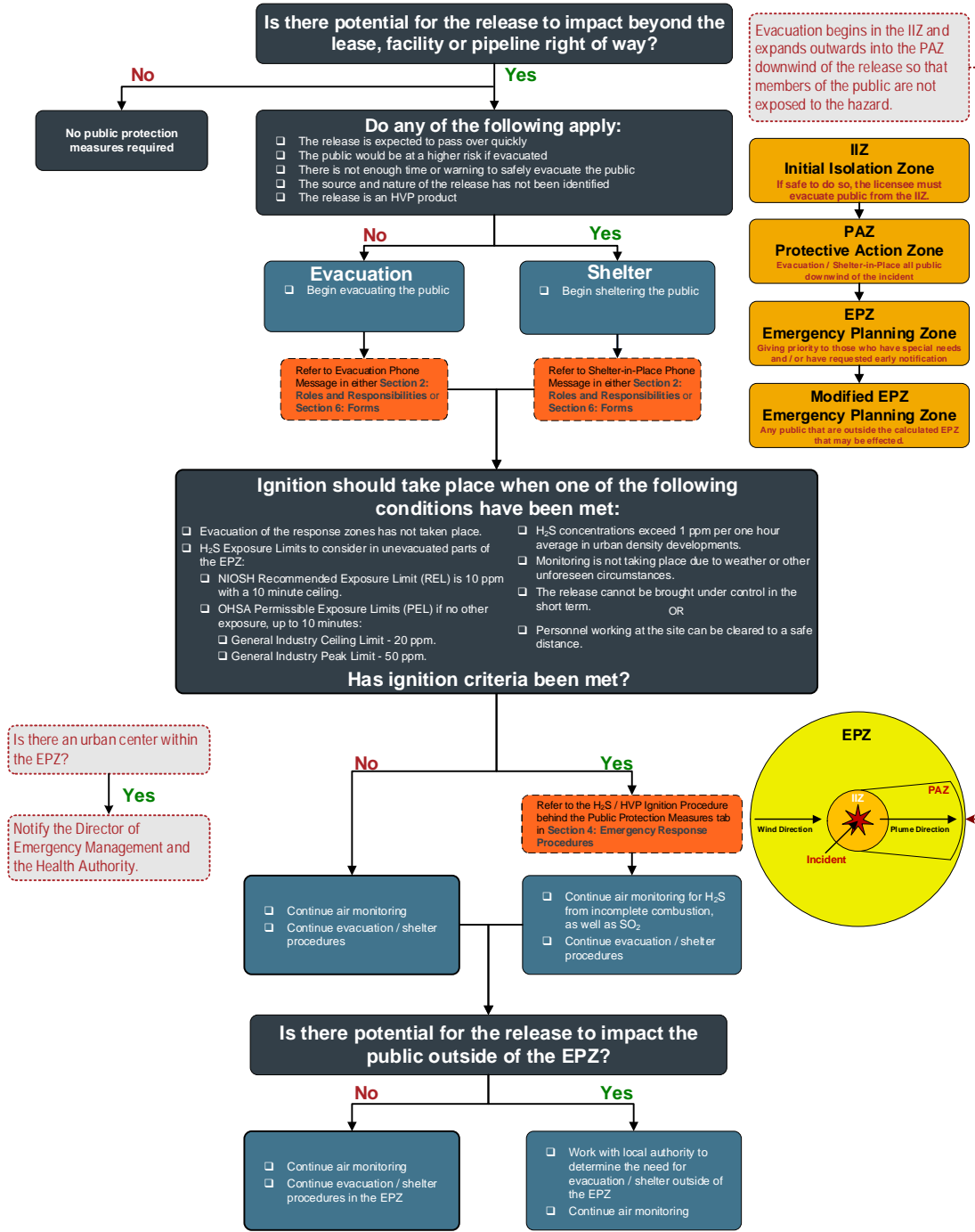

Evacuation Standards

For a sour gas release, the licensee must continuously assess and act on the need to expand the evacuation area based on the monitored levels of H₂S and SO₂. In the absence of monitored readings, responders should advise residents to Shelter-in-Place.

H ₂ S Standards		SO ₂ Standards	
NIOSH REL 1-10 ppm OSHA PEL 1-20 ppm (10 minute ceiling average)	Individuals who requested notification so that they can voluntarily evacuate before any exposure to H ₂ S should be notified.	NIOSH REL (10-hour TWA) 2 ppm TWA / 5 ppm STEL	Immediate evacuation of the area should take place.
Above 20 ppm (10 minute ceiling average)	Local conditions should be assessed and all persons should be advised to evacuate and/or shelter.	OSHA PEL (8-hour TWA) 5 ppm TWA	
If monitored levels over the 10 minute interval are declining (i.e., three readings show a decline from 20 ppm to 15 ppm to 10 ppm over 10 minutes), evacuation may not be necessary even though the average over the 10 minute interval would be 15 ppm. Licensees should use proper judgement in determining if evacuation is required.		PEL = Permissible Exposure Limit REL = Recommended Exposure Limit STEL = Short Term Exposure Limit TWA = Time-Weighted Average	

Revised March 2023



Section 2: Roles and Responsibilities

Field Response Team

Key Response Personnel

General Safety Equipment and Resource Lists

Operator, Truck & Other Safety Equipment

Response Team Structure

Quick Reference Guide – Emergency Support Team (EST)

Field Response Team – Command Staff

Command Staff Roles Chart

Field Response Team – General Staff

Operations Section Roles Chart

Planning Section Roles Chart

Logistics Section Roles Chart

Finance / Admin. Section Roles Chart

Field Response Team – Public Safety Staff

Public Safety Roles Chart

Air Monitors Module

Reception Centre Rep Module

Roadblocks Module

Rovers Module

Telephoners Module

Ongoing Response

Planning “P”

Five Step Ongoing Response Guide

Objectives Meeting

Tactics Meeting

Planning Meeting

Operations Briefing

Response Teams Phone List



Field Response Team

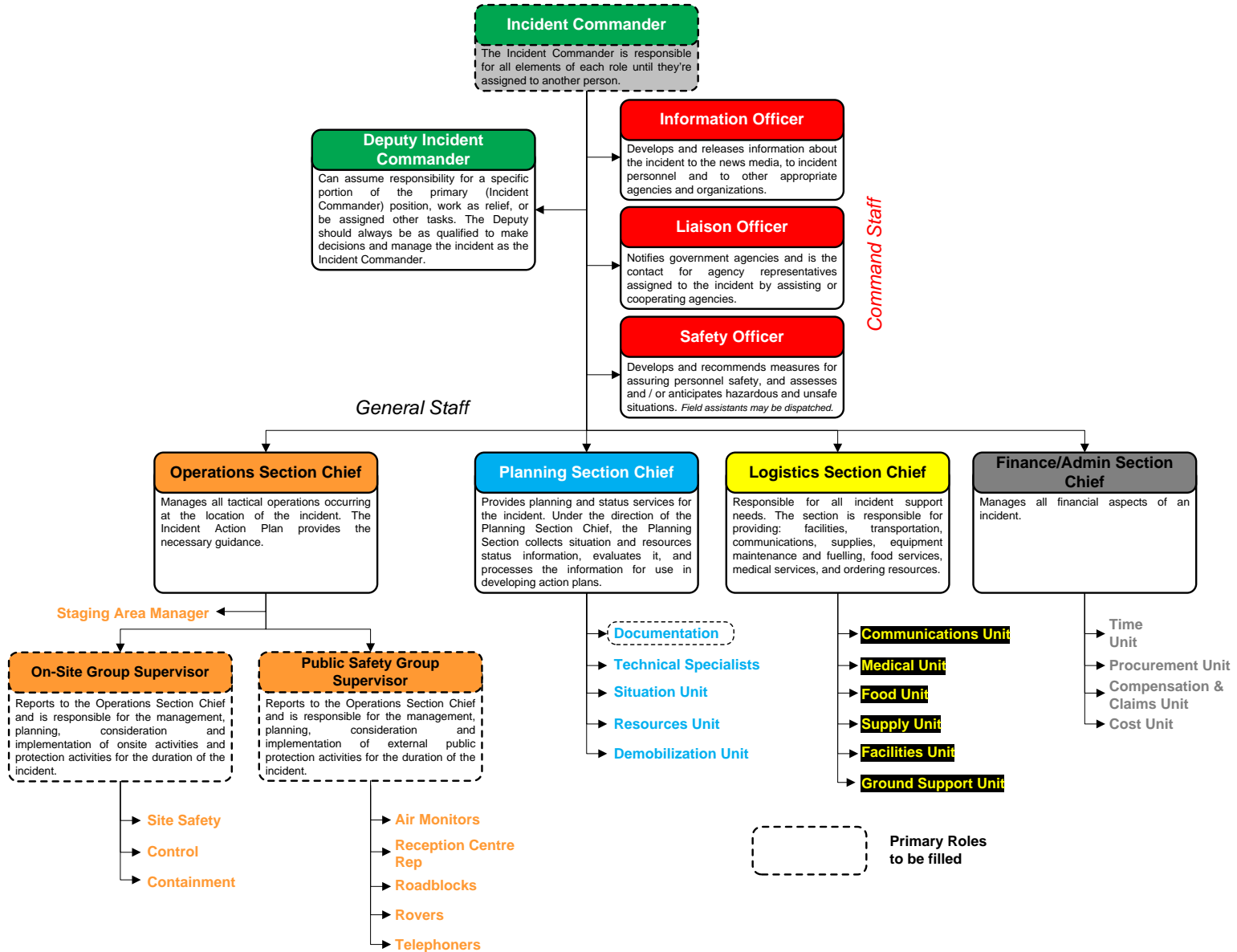

Section 2: Roles and Responsibilities



Key Response Personnel

The following individuals are likely to fill the key response roles identified:

Command Staff	Incident Commander	Area Superintendent Area Foreman (Alternate Incident Commander)
On-Site	On-Site Group Supervisor	Lead Operators Please see the Response Teams Phone List (Yellow tab) or Area Specific Information (White tabs) for a list of Area Operators.
	Trained in Ignition (H₂S & HVP)	Lead Operator Lead Operator
Public Safety	Public Safety Group Supervisor	Area Foreman Area Superintendent
	Air Monitors / Roadblock / Rovers	Area Operators Please see the Response Teams Phone List (Yellow tab) or Area Specific Information (White tabs) for a list of Area Operators.
	Telephoners	Operations Technician
	Reception Centre Representative	Area Operators Please see the Response Teams Phone List (Yellow tab) or Area Specific Information (White tabs) for a list of Area Operators.
Emergency Support Team (EST)	EOC Director	VP & COO VP Operations & Facilities
	Communications / Media	Media Representative

Please refer to the **Response Teams Phone List (Yellow tabs)** or **Area Specific Information (White tabs)** for the full list of personnel and their contact information.

General Safety Equipment and Resource Lists

Operator, Truck & Other Safety Equipment

Each operator is required to drive a suitable vehicle (4x4 truck) for their service areas and should carry the following equipment: 20-30lb fire extinguisher, vehicle emergency roadside kit, cell phone and a 4 head monitor.

Refer to **Area Specific Information Section (white tabs)** for further details on specific air monitoring equipment, back-up communication methods, ignition and roadblock kit contents as well as their locations, specialty fire-fighting equipment and/or service companies and their contact information for if the aforementioned equipment is not available.



Response Team Structure

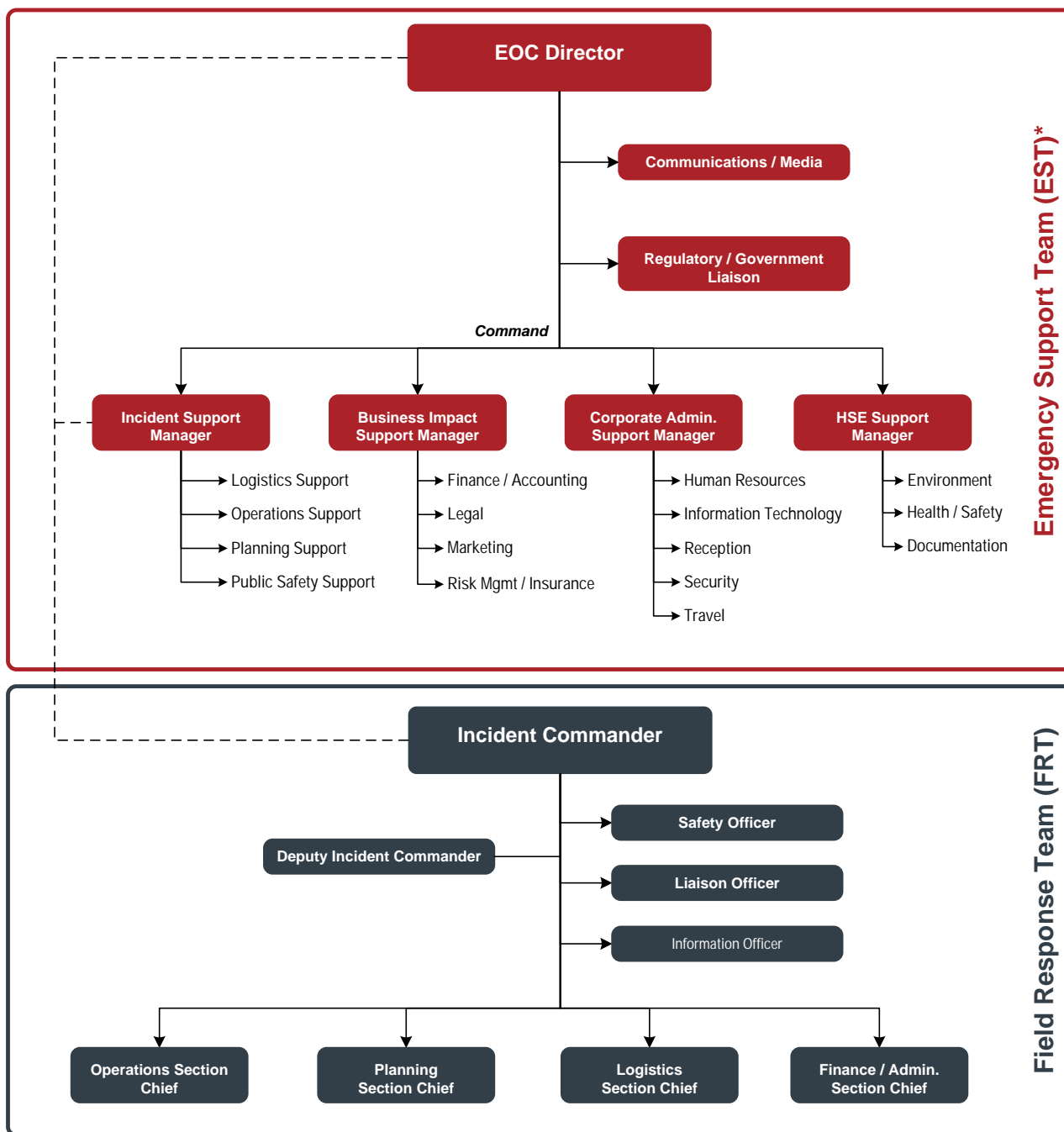



Quick Reference Guide – Emergency Support Team (EST)

(Located at the Corporate Emergency Operations Centre)

The **EOC Director** is responsible for all elements of each role until they're assigned to another person. Below are brief descriptions of each of the key roles that the EOC Director might choose to assign right away.

EOC Director	The EOC Director is responsible for coordination of response efforts from corporate to support the Field Response Team (FRT) and for efforts to ensure business continuity during the incident. The EOC Director determines the level of activation of the Emergency Support Team (EST) and assigns all positions to meet the required level of activation.
Communications & Media	Serves as the coordination point for all public information, media relations and internal information sources. Communications & Media is responsible for preparing the FRT and the EST to deal successfully with internal and external communication.
Regulatory / Government Liaison	Provides regulatory guidance and advice to the EST as well as to be a liaison between responding government agencies and the company. The Regulatory / Government Liaison is responsible for providing support to the field Liaison Officer.
Incident Support Manager	The Incident Support Manager is the main link between the FRT and the EST and is the main informant for the EST. The Incident Support Manager speaks directly with the field Deputy Incident Commander, if assigned, or the field Incident Commander. The Incident Support Manager provides operational, public safety, planning and logistics advice and support to assist the FRT with developing an effective field Incident Action Plan (IAP).
Business Impact Support Manager	The role of business impact is to identify and work to mitigate all of the negative impacts of the incident on the business as well as to provide business advice and support. The Business Impact Support Manager provides support to the company in the areas of finance / accounting, legal, marketing, risk management and insurance.
Corporate Admin Support Manager	The Corporate Admin Support Manager provides administrative and technical support to the company in the areas of human resources, information technology, travel, security and reception.
Health, Safety & Environment Support Manager	The Health, Safety & Environment Support Manager is responsible for providing Health, Safety & Environmental support to the FRT. The Health, Safety & Environment Support Manager is also responsible for managing the health / safety / environmental / planning / documentation activities of the EST.

Command Staff Roles

Incident Commander	Deputy Incident Commander	Information Officer	Liaison Officer	Safety Officer
<p>The Incident Commander is in charge of overall management of the incident and must be fully qualified to manage the incident. As incidents grow in size or complexity, a more highly qualified Incident Commander may be assigned by the company.</p> <p><i>Note: The highest ranking authority arriving at the site of the incident (first on-scene) becomes the Incident Commander and establishes command and control. The first on-scene will remain the Incident Commander until there is formal transfer of command to a more senior company employee and / or qualified personnel.</i></p> <p>Initial Response - *Refer to the 5 Step Initial Response Guide in Section 1: Initial Response*</p> <p>Step 1: Level of Emergency</p> <ul style="list-style-type: none"> ❑ If necessary, investigate and confirm the emergency. If the incident involves a release of sour product, the investigation should be conducted in teams of two. Take appropriate safety precautions (PPE, SCBA, etc.). Ensure personal safety at all times. ❑ Determine the Level of Emergency using the OGC Incident Classification Matrix for BC or AER's Assessment Matrix for Classifying Incidents for all other provinces (e.g. Alert/Minor, Level 1, 2, 3) found in Section 1: Initial Response or using the Emergency Assessment SmartPhone App. (Search H₂Safety or Emergency Assessment in the App Store). <p>Step 2: Internal Notification</p> <ul style="list-style-type: none"> ❑ Follow the Internal Emergency Notification Flowchart outlined in Section 1: Initial Response to contact required field resources. Refer to the Section 2: Roles and Responsibilities / Response Team Phone List. Relay the information from the A1 Initial Notification Form. Mobilize internal resources to the site, to the Incident Command Post (ICP) or place them on standby as required. ❑ Contact required company resources and communicate the level of emergency. Refer to Section 2: Roles and Responsibilities / Response Team Phone List. <p>Step 3: External Notification</p> <ul style="list-style-type: none"> ❑ Follow the External Emergency Notification Flowchart in Section 1: Initial Response for communication structure and the Provincial Notification Matrix in Section 5: External Agencies to determine which external agencies need to be notified. Reference Section 5: External Agencies and the Area Specific Information for the location of the incident. <p>Step 4: Incident Briefing</p> <ul style="list-style-type: none"> ❑ The following positions are always filled regardless of the size of the incident: Incident Commander, On-Site Group Supervisor and Documentation. ❑ Assess the situation, identify the incident source, and consider how to stop the source. Carry out a site assessment that includes the following: identify hazardous materials, evaluate risk to workers and the public, determine the potential for the incident to escalate, identify safety concerns, determine which other company's facilities are involved. ❑ Detail and prioritize the objectives for the next operational period taking into consideration the priorities of (1) Life Safety, (2) Incident Stabilization, (3) Property & Environment using the ICS 201 Incident Briefing Form. ❑ Assign other positions as required to meet the identified objectives. Review and complete the ICS 207 Incident Organization Chart in Section 6: Forms. Depending on the scale of emergency, all positions may not be assigned. The Incident Commander assumes responsibility for all unassigned roles until personnel have been assigned to them. ❑ Conduct a role review with each of the positions above to ensure they clearly understand their roles and responsibilities. ❑ Develop detailed plans of action (strategies) to achieve the objectives and determine what tactics and resources are required to implement the strategies (oil spill services, safety services, etc.). ❑ Activate the Incident Command Post (ICP). Refer to the Appendices for Incident Command Post activation guidelines. ❑ Ensure the Planning Section posts and updates the status board with incident details. <p>Step 5: Public Safety</p> <ul style="list-style-type: none"> ❑ Determine the size of the Emergency Planning and Response Zones around the incident. Refer to the EPZ calculation tables and map in Area Specific Information. ❑ Use the Public Protection Measures Flowchart located in Section 1: Initial Response to assist with determining if evacuation / shelter / ignition are required. ❑ Ensure the affected public are contacted and advised to shelter or evacuate as required. ❑ Establish Air Monitoring, Reception Centre Representatives, Roadblocks, Rovers, and Telephoners as required. <p>Ongoing Response - *Refer to the Five Step Ongoing Response Guide in Section 2: Ongoing Response*</p> <ul style="list-style-type: none"> ❑ Establish a method to track responders and resources to ensure they are accounted for at all times. ❑ Monitor implementation of IAP and revise as the situation dictates. Prepare for next operational period. ❑ Support the Operations Section Chief in the preparation of an incident control and containment action plan. ❑ Ensure each section chief has adequate staff, is not violating span of control and clearly understands the roles and responsibilities. ❑ Conduct frequent Command Staff and General Staff meetings and regularly update the Emergency Support Team. ❑ If transfer of command occurs, an incident status briefing must take place. Provide all documentation and review situation status, objectives and priorities, current organization and resources, facilities, communications plan, concerns and introductions to staff. ❑ As the emergency is brought under control, the decision to downgrade the level and/or stand down the emergency will be based on air monitoring readings in consultation with the Incident Commander and the applicable government regulator. ❑ The Demobilization Unit will develop and implement objectives/strategies for demobilization. 	<p>The Deputy Incident Commander may assume responsibility for a specific portion of the primary position, work as relief, or be assigned other tasks. The Deputy should always be as qualified to make decisions and manage the incident as the Incident Commander.</p> <ul style="list-style-type: none"> ❑ If no scribe has been assigned to the Incident Commander, support the Incident Commander by documenting details of the emergency, focusing on activities and decisions made. ❑ Record, update and maintain a chronological summary of the incident including: <ul style="list-style-type: none"> ❑ Names of personnel in each assigned position and their location ❑ Control and containment measures ❑ Environmental monitoring information ❑ Injuries / deaths / missing persons ❑ Phone calls ❑ Actions and decisions ❑ Status of the public protection actions ❑ Manage the flow of traffic to and communication with the Incident Commander so that he can focus on managing the incident. ❑ Conduct status update meetings. ❑ Provide status to head office. ❑ Deal with some day-to-day decision making. ❑ Assume duties of the Incident Commander, if required. ❑ Maintain communication with the Incident Commander. <div style="border: 2px solid red; padding: 5px; margin-top: 10px;"> <p style="text-align: center; color: red; font-weight: bold;">Important</p> <p>Prior to beginning any activities, each person in a role must:</p> <ul style="list-style-type: none"> ❑ Obtain a completed ICS 201 Incident Briefing and ICS 207 Incident Organization Chart from the Incident Commander. <p>Throughout the duration of the incident, each person in a role must:</p> <ul style="list-style-type: none"> ❑ Chronologically document all actions, decisions, contacts and requests on an ICS 214 Activity Log. Copies can be found in Section 6: Forms. <p>After the incident is over, each person in a role must:</p> <ul style="list-style-type: none"> ❑ Assist with post-incident activities. <p style="text-align: center; color: red; font-weight: bold;">All forms referenced can be found in Section 6: Forms</p> </div>	<p>The Information Officer is responsible for developing and releasing information about the incident to the news media, to incident personnel and to other appropriate agencies and organizations.</p> <ul style="list-style-type: none"> ❑ Receive incident briefing from the Incident Commander before contacting external agencies. ❑ Prepare regular status updates that will be provided to internal company personnel to keep them apprised of the situation. ❑ Identify and document any media involvement that has already taken place ❑ If the media statement hasn't yet been prepared ensure that the generic media statement from the ERP is communicated and being used in the field. ❑ Assist head office with the preparation of a preliminary media statement if required using the Preliminary Media Statement form. ❑ Document all communications with the media using the Media Contact Log. ❑ Develop a detailed media strategy for the incident. ❑ Designate and prepare media briefing rooms away from the Incident Command Post. ❑ Organize tours and photo opportunities if required. ❑ Maintain communication with the Incident Commander. ❑ Media releases must be coordinated with applicable regulatory agency. ❑ If necessary, coordinate with and use broadcast media to notify residents in the hazard area. ❑ Work with Communications / Media to develop a communications plan that includes establishing protocols for responders and all company personnel as required to ensure incident information remains confidential (i.e. restriction on cell phone usage for photography, social media, speaking to the media, etc.). 	<p>The Liaison Officer is responsible for notifying government agencies and is the contact for agency representatives assigned to the incident by assisting or cooperating agencies.</p> <ul style="list-style-type: none"> ❑ Complete Regulatory First Call Communication Form. Form A3 ❑ Refer to Section 5: External Agencies for the Government Notification Matrix. Notify as soon as possible and provide status updates at agreed upon intervals to: <ul style="list-style-type: none"> ❑ Government regulator ❑ Local authorities (counties, cities, towns, MDS, First Nations Reserves, etc.) ❑ Health authority ❑ Environment ❑ Provincial emergency management organization ❑ Other agencies ❑ Keep track of all government correspondence using the Government Agency Contact Log. Form C3 ❑ Obtain cooperating and assisting agency information that includes: contact information, radio frequencies, cooperative agreements, equipment type, number of personnel, condition of equipment and personnel, agency constraints, etc. ❑ Conduct appropriate periodic briefings to keep agencies informed of planning actions. ❑ Coordinate with any government agency representatives attending the ICP or REOC. ❑ Coordinate with mutual aid groups. 	<p>The Safety Officer develops and recommends measures for assuring personnel safety, and assesses and / or anticipates hazardous and unsafe situations.</p> <ul style="list-style-type: none"> ❑ Ensure the site is evacuated if unsafe. ❑ Initiate rescue plans if safe to do so. ❑ Review the Incident Action Plan to identify and correct any potential occupational and health hazards. ❑ Ensure work / rest guidelines are followed. ❑ Continuously monitor workers for exposure to ensure they are wearing the required PPE. ❑ Take appropriate action to mitigate or eliminate unsafe conditions, operations, or hazards. ❑ Immediately stop any unsafe practices. ❑ Conduct a general inspection of the facilities, food services and sanitation services soon after they become operational and follow up on a periodic basis throughout the incident for compliance to all health and safety standards. Provide a report of deficiencies. ❑ Document both safe and unsafe acts, corrective actions taken on the scene, accidents or injuries, and ways to improve safety on future incidents. ❑ Investigate accidents that have occurred within the incident area. ❑ Identify "Hot Zone" and declare when responders may enter it. ❑ Ensure that responders inside the "Hot Zone" are accounted for and initiate search if required. ❑ Prepare a site-specific health and safety plan.

All team members are located at the Incident Command Post (ICP), unless otherwise noted.

Revised October 2018

Escalate, Downgrade or Stand-Down Levels of Emergency: As the emergency is brought under control, the decision to downgrade the level and/or stand down the emergency will be based on air monitoring readings in consultation with the **Incident Commander** and the applicable government regulator. All affected persons and the media must be kept informed of the status of an emergency. **Emergency Follow-up:** Once the emergency is over, the area residents, transients, industrial users, involved government agencies, and any individual notified will be informed of the stand-down by the **Information Officer** or **Public Safety Group Supervisor**.

General Staff Roles – Operations Section

Operations Section Chief	On-Site Group Supervisor	Staging Area Manager	Site Safety	Control	Containment
<p>The Operations Section Chief is responsible for managing all tactical operations occurring at the location of the incident. The Incident Action Plan provides the necessary guidance. The need to expand the Operations Section is generally dictated by the number of tactical resources involved and is influenced by span of control considerations.</p>	<p>On-Site Group Supervisor is responsible for coordinating all activities of Control, Containment and Site Safety at the scene of the emergency / incident.</p>	<p>The Staging Area Manager is responsible for managing all activities within a Staging Area.</p>	<p>Site Safety is responsible for responder safety and safety advice at all times at the scene of the emergency / incident.</p>	<p>Control is responsible for implementing measures designed to bring the incident under control or stop the incident.</p>	<p>Containment is responsible for implementing measures designed to reduce the impact of the incident on and prevent the spread of the incident to the surrounding areas.</p>
<ul style="list-style-type: none"> ❑ Identify and confirm communication links. ❑ Ensure the On-Site Command Post (OSCP) is established. ❑ Manage the following positions, as required: On-Site Group Supervisor, Public Safety Group Supervisor. ❑ In conjunction with the Incident Commander, the Planning Section Chief, and the Public Safety Group Supervisor, develop and implement an Incident Action Plan (IAP). ❑ Ensure responder safety at all times. ❑ Oversee control / containment procedures; ensure the hazard is isolated. ❑ Determine the current and potential environmental impact of product released, response activities, or waste disposal. ❑ Ensure that all environmental laws and regulations are complied with during emergency response operations. ❑ Provide technical advice to Incident Commander to determine public protection measures. ❑ Assess the requirements for on-site safety supervision, personnel, equipment, and other contract services. Coordinate with Logistics to obtain equipment and resources. ❑ Assist the On-Site Group Supervisor in determining whether ignition is appropriate. If at all possible, input is to be obtained from the Incident Commander, the EOC Director and the applicable government regulator. ❑ Maintain continuous communications with the Incident Commander. 	<ul style="list-style-type: none"> ❑ Ensure all personnel are accounted for. Release nonessential personnel from the site. ❑ Oversee and maintain control of all on-site personnel. ❑ Establish On-Site Command Post (OSCP). ❑ Obtain incident briefing and environmental impact information. ❑ Coordinate activities of Staging Area Manager, Site Safety, Control and Containment. ❑ Report air monitoring to Incident Commander (third party and regulatory). ❑ Call police, fire and ambulance as needed. ❑ Coordinate with ambulance / fire / police / regulatory agencies / OSROs. ❑ Conduct meetings with on-site personnel to review action plans, communication, and safety. ❑ Request additional resources needed to implement on-site response actions. ❑ Supervise the execution of the on-site response actions. ❑ The On-Site Group Supervisor has the authority to ignite the release if ignition criteria are met. If at all possible, the On-Site Group Supervisor must consult with higher authority individuals within the company (ideally the Operations Section Chief, Incident Commander, EOC Director, etc.) and the applicable government regulator before making the decision to ignite a release. Refer to Section 4: Emergency Response Procedures. 	<ul style="list-style-type: none"> ❑ Establish a staging area near the incident site and outside of the EPZ. When choosing a site for the staging area ensure the following conditions are met: <ul style="list-style-type: none"> ❑ Adequate sized site that is stable and level with suitable access roads ❑ No entry problems such as narrow approach ways, gates, power lines, buried pipelines, etc. ❑ Approval has been received from landowner ❑ Reception of communication equipment is adequate ❑ Erect staging area information and directional signs to the staging area, if required. ❑ Flag the perimeter of the staging area. ❑ Obtain an office trailer and emergency lighting, if required. ❑ Coordinate traffic and maintain a log of personnel and services dispatched to or arriving from the site of the emergency. Communicate this information to the Logistics Section Chief. ❑ Respond to Operations Section Chief or Incident Commander requests for resources. ❑ Confirm all workers have required training before they are dispatched to the incident. ❑ Maintain and provide status to the Planning Section of all resources in Staging Area. ❑ Demobilize or move Staging Area as required. 	<ul style="list-style-type: none"> ❑ Assess hazards & potential risks e.g. fire/explosion, toxicity, oxygen deficiency, ignition sources, access/egress. ❑ Ensure responder safety at all times. ❑ Ensure that on-site personnel are taking appropriate safety actions: PPE, SCBA / SABA, Safe Work Procedures, proper grounding / bonding procedures, work in teams, etc. ❑ Maintain security of the site to ensure authorized personnel are allowed access and to protect response personnel. ❑ Ensure security of any evidence for investigative purposes. ❑ Ensure workers that show signs of stress, fatigue, and other symptoms are demobilized and sent for treatment if necessary. ❑ Maintain records of all injuries and on-site medical treatments. ❑ Conduct responder safety orientations. ❑ Monitor activities and conduct a head count on a regular basis. ❑ Continually evaluate risks and stop unsafe activities immediately. ❑ Recommend alternatives for activities that are considered to be unsafe. 	<ul style="list-style-type: none"> ❑ Assist with the development of control procedures. ❑ Identify immediate response tactics (i.e. offensive / defensive response tactics). Only when safety is assured, take immediate operational actions to bring the incident under control (i.e. shut down, isolate, de-pressure, etc.). ❑ Provide or seek technical / engineering advice around all control-related issues. ❑ Inform Operations Section Chief of any interactions with regulatory agencies or environmental personnel. 	<ul style="list-style-type: none"> ❑ Assist with the development of containment procedures. ❑ Identify immediate response tactics (i.e. offensive / defensive response tactics). Only when safety is assured, take actions to contain the incident so as to prevent the incident from spreading offsite and to reduce the impact on the public, sensitive terrain, watercourses, etc. ❑ Provide or seek technical / engineering advice around all containment-related issues. ❑ Secure the scene and restrict access to essential and authorized personnel only. ❑ Inform Operations Section Chief of any interactions with regulatory agencies or environmental personnel. ❑ Coordinate oil spill cooperative activities (booms, dams, etc.).
<p>Important</p> <p>Prior to beginning any activities, each person in a role must:</p> <ul style="list-style-type: none"> ❑ Obtain a completed ICS 201 Incident Briefing and ICS 207 Incident Organization Chart from the Incident Commander. <p>Throughout the duration of the incident, each person in a role must:</p> <ul style="list-style-type: none"> ❑ Chronologically document all actions, decisions, contacts, and requests on an ICS 214 Activity Log. Copies can be found in Section 6: Forms. <p>After the incident is over, each person in a role must:</p> <ul style="list-style-type: none"> ❑ Assist with post-incident activities. <p style="color: red; font-weight: bold;">All forms referenced can be found in Section 6: Forms</p>					
Located at the Incident Command Post (ICP)	Located at the On-Site Command Post (OSCP)	Located at the Staging Area	Located at the On-Site Command Post (OSCP)	Located at the On-Site Command Post (OSCP)	Located at the On-Site Command Post (OSCP)

Revised April 2022

Escalate, Downgrade or Stand-Down Levels of Emergency: As the emergency is brought under control, the decision to downgrade the level and/or stand down the emergency will be based on air monitoring readings in consultation with the **Incident Commander** and the applicable government regulator. All affected persons and the media must be kept informed of the status of an emergency. **Emergency Follow-up:** Once the emergency is over, the area residents, transients, industrial users, involved government agencies, and any individual notified will be informed of the stand-down by the **Information Officer** or **Public Safety Group Supervisor**.

General Staff Roles – Planning Section

Planning Section Chief	Documentation Unit	Technical Specialists Unit	Situation Unit	Resources Unit	Demobilization Unit																			
<p>The Planning Section Chief is responsible for providing planning and status services for the incident. Under the direction of the Planning Section Chief, the Planning Section collects situation and resources status information, evaluates it, and processes the information for use in developing action plans. Dissemination of information can be in the form of the Incident Action Plan, formal briefings, or through map and status board displays.</p>	<p>The Documentation Unit is responsible for the maintenance of accurate, up-to-date incident files. Duplication services will also be provided by the Documentation Unit.</p>	<p>Certain incidents or events may require the use of Technical Specialists who have specialized knowledge and expertise. Technical Specialists may function within the Planning Section, or be assigned wherever their services are required.</p>	<p>The collection, processing, and organization of all incident information. The Situation Unit may prepare future projections of incident growth, maps, and intelligence information.</p>	<p>The Resources Unit is responsible for maintaining the status of all assigned resources at an incident.</p>	<p>The Demobilization Unit is responsible for developing the Incident Demobilization Plan.</p>																			
<ul style="list-style-type: none"> <input type="checkbox"/> Identify and confirm communication links. <input type="checkbox"/> Assign personnel to assume the following positions, as required: Documentation, Technical, Situation, Resources, and Demobilization. <input type="checkbox"/> Assist with setup of the Incident Command Post. <input type="checkbox"/> Review the details of the incident and support the Incident Commander with the development of a preliminary response strategy. <input type="checkbox"/> Identify the need for technical specialists. <input type="checkbox"/> Collect and analyze information on the current situation, prepare situation displays and situation summaries, and develop maps and projections. <input type="checkbox"/> Establish special information collection activities as necessary, e.g., weather, environmental, toxics, etc. <input type="checkbox"/> Provide technical support to the Incident Commander and work with Incident Commander to develop the Incident Action Plan (IAP). <input type="checkbox"/> Review any changes to the Incident Action Plan (IAP) to ensure consistency. <input type="checkbox"/> Assemble information on alternative strategies. <input type="checkbox"/> Coordinate with Logistics to determine current available resources and resource availability for future plans of action. <input type="checkbox"/> Establish reporting schedules. <input type="checkbox"/> Conduct long-range and / or contingency planning. <input type="checkbox"/> Develop plans for demobilization. <input type="checkbox"/> Maintain continuous communications with the Incident Commander. <div style="text-align: right; margin-top: 10px;"> <table border="1" style="display: inline-table; border-collapse: collapse;"> <tr> <td>Form ICS 202</td> <td>Form ICS 214</td> <td>Form ICS 215</td> <td>Form ICS 215a</td> <td>Form ICS 230</td> </tr> </table> </div>	Form ICS 202	Form ICS 214	Form ICS 215	Form ICS 215a	Form ICS 230	<ul style="list-style-type: none"> <input type="checkbox"/> Document the Incident Action Plan (IAP) strategies using the ICS 201 Incident Briefing Form provided in Section 1: Initial Response or Section 6: Forms and disseminate them to all key responders. <ul style="list-style-type: none"> <input type="checkbox"/> Be prepared to document the Incident Commander's status update meetings using whiteboards, PC or Action Logs. <input type="checkbox"/> Ensure consistent documentation. <input type="checkbox"/> Ensure timely dissemination of all documentation. <input type="checkbox"/> Participate in planning meetings, capturing key information, decisions made, commitments and status. <input type="checkbox"/> Collect documentation from response team members and maintain a consistent system for organizing the data. <ul style="list-style-type: none"> <input type="checkbox"/> Records must be held for a minimum of 5 years as it may be requested by the regulatory agency at any point during that time. <input type="checkbox"/> Establish duplication services. <input type="checkbox"/> Incident files will be stored for legal, analytical, and historical purposes. <input type="checkbox"/> Post and maintain all Emergency Status Boards and other laminated charts in the Incident Command Post. <div style="text-align: right; margin-top: 10px;"> <table border="1" style="display: inline-table; border-collapse: collapse;"> <tr> <td>Form ICS 201</td> <td>Form ICS 214</td> <td>Form ICS 231</td> <td>Form ICS 233</td> </tr> </table> </div>	Form ICS 201	Form ICS 214	Form ICS 231	Form ICS 233	<ul style="list-style-type: none"> <input type="checkbox"/> Determine what technical support is available now and in the future. <input type="checkbox"/> Work with Logistics to determine the key locations for the required technical support and appropriate time to acquire. <input type="checkbox"/> Gather data (weather, etc.) and forecast changes considering incident potential and develop new or modified response strategies. <input type="checkbox"/> As required, obtain plume dispersion modelling. 	<ul style="list-style-type: none"> <input type="checkbox"/> Collect and evaluate information to establish an accurate picture of the situation and creates a detailed summary. Use this information to create maps and projections. <input type="checkbox"/> Prepare, post, or disseminate resources and situation status information as required, including special requests. <input type="checkbox"/> Provide photographic services and maps if required. <div style="text-align: right; margin-top: 10px;"> <table border="1" style="display: inline-table; border-collapse: collapse;"> <tr> <td>Form ICS 201</td> <td>Form ICS 209</td> <td>Form ICS 214</td> </tr> </table> </div>	Form ICS 201	Form ICS 209	Form ICS 214	<ul style="list-style-type: none"> <input type="checkbox"/> Monitor the status and location of all incident resources / personnel responding to the incident. <input type="checkbox"/> Oversee the check-in of all resources. <input type="checkbox"/> Maintenance of a master list of all resources, e.g., key supervisory personnel, primary and support resources, etc. <input type="checkbox"/> May assist in preparing the written Incident Action Plan. <input type="checkbox"/> Maintain and post the current status and location of all resources. <div style="text-align: right; margin-top: 10px;"> <table border="1" style="display: inline-table; border-collapse: collapse;"> <tr> <td>Form ICS 203</td> <td>Form ICS 204</td> <td>Form ICS 207</td> <td>Form ICS 211</td> <td>Form ICS 214</td> </tr> </table> </div>	Form ICS 203	Form ICS 204	Form ICS 207	Form ICS 211	Form ICS 214	<ul style="list-style-type: none"> <input type="checkbox"/> Prepare plan for the demobilization of all personnel and equipment upon resolution of the incident. <input type="checkbox"/> Ensure resources in available status are still required. Identify surplus resources and probably release time. <input type="checkbox"/> Debrief non-required resources and dismiss resources being demobilized. <input type="checkbox"/> Coordinate demobilization with agency representatives. <input type="checkbox"/> Develop incident check-out function for all units. <input type="checkbox"/> Ensure the demobilization process is organized, safe and cost effective. <div style="text-align: right; margin-top: 10px;"> <table border="1" style="display: inline-table; border-collapse: collapse;"> <tr> <td>Form ICS 214</td> <td>Form ICS 221</td> </tr> </table> </div>	Form ICS 214	Form ICS 221
Form ICS 202	Form ICS 214	Form ICS 215	Form ICS 215a	Form ICS 230																				
Form ICS 201	Form ICS 214	Form ICS 231	Form ICS 233																					
Form ICS 201	Form ICS 209	Form ICS 214																						
Form ICS 203	Form ICS 204	Form ICS 207	Form ICS 211	Form ICS 214																				
Form ICS 214	Form ICS 221																							
<div style="border: 2px solid red; padding: 5px; margin: 0 auto; width: 80%;"> <p style="text-align: center; margin: 0;">Important</p> <p>Prior to beginning any activities, each person in a role must:</p> <ul style="list-style-type: none"> <input type="checkbox"/> Obtain a completed ICS 201 Incident Briefing and ICS 207 Incident Organization Chart from the Incident Commander. <p>Throughout the duration of the incident, each person in a role must:</p> <ul style="list-style-type: none"> <input type="checkbox"/> Chronologically document all actions, decisions, contacts and requests on an ICS 214 Activity Log. Copies can be found in Section 6: Forms. <p>After the incident is over, each person in a role must:</p> <ul style="list-style-type: none"> <input type="checkbox"/> Assist with post-incident activities. <p style="text-align: center; color: red; font-weight: bold; margin: 0;">All forms referenced can be found in Section 6: Forms</p> </div>																								

All team members are located at the Incident Command Post (ICP), unless otherwise noted.

Revised October 2018

Escalate, Downgrade or Stand-Down Levels of Emergency: As the emergency is brought under control, the decision to downgrade the level and/or stand down the emergency will be based on air monitoring readings in consultation with the **Incident Commander** and the applicable government regulator. All affected persons and the media must be kept informed of the status of an emergency. **Emergency Follow-up:** Once the emergency is over, the area residents, transients, industrial users, involved government agencies, and any individual notified will be informed of the stand-down by the **Information Officer** or **Public Safety Group Supervisor**.

General Staff Roles – Logistics Section

Logistics Section Chief	Communications Unit	Medical unit	Food Unit	Supply Unit	Facilities Unit	Ground Support Unit
<p>All incident support needs are provided by the Logistics Section. The section is responsible for providing: facilities, transportation, communications, supplies, equipment maintenance and fuelling, food services, medical services, and ordering resources. Six units may be established within the Logistics Section and the Logistics Section Chief will determine the need to activate or deactivate a unit. If a unit is not activated, responsibility for that unit's duties will remain with the Logistics Section Chief.</p>	<p>The Communications Unit is responsible for developing plans for the use of incident communications equipment and facilities; installing and testing of communications equipment; supervision of the Incident Communications Centre, if established; and the distribution and maintenance of communications equipment.</p>	<p>The Medical Unit is responsible for all medical services for incident assigned personnel. The unit will develop procedures for managing major medical emergencies; and provide medical aid.</p> <p><i>Note: Medical assistance to the public or victims of the emergency is an operational function.</i></p>	<p>Responsible for supplying the food needs for the entire incident, including all remote locations, (e.g., Camps, Staging Areas), as well as providing food for personnel unable to leave tactical field assignments. The Food Unit interacts with the Facilities Unit for location of fixed-feeding site; the Supply Unit for food ordering; and the Ground Support Unit for transporting food.</p>	<p>The Supply Unit is responsible for ordering, receiving, processing, and storing all incident-related resources.</p>	<p>The Facilities Unit is responsible for set-up, maintenance, and demobilization of all incident support facilities except staging areas. The Facilities Unit will also provide security services to the incident as needed.</p>	<p>The Ground Support Unit is primarily responsible for the maintenance, services, and fuelling of all mobile equipment and vehicles, with the exception of aviation resources. The unit also has responsibility for the ground transportation of personnel, supplies, and equipment.</p>
<ul style="list-style-type: none"> <input type="checkbox"/> Identify and confirm communication links. <input type="checkbox"/> Assign personnel as required. <input type="checkbox"/> List and obtain all immediate resources requested by the Incident Commander or Operations Section Chief. <input type="checkbox"/> Identify anticipated and known incident service and support requirements. <input type="checkbox"/> Maintain continuous communications with the Incident Commander. <input type="checkbox"/> Develop plans to move required resources to site. <input type="checkbox"/> Confirm spending authorities with the Finance / Admin Section. <input type="checkbox"/> Mobilize resources. <input type="checkbox"/> Move required resources to site. <input type="checkbox"/> Coordinate spending with the Finance / Admin Section Chief. 	<ul style="list-style-type: none"> <input type="checkbox"/> Establish the communications plan for the use of incident communications equipment and facilities. <input type="checkbox"/> Install, test, distribute, and maintain all communications equipment. <input type="checkbox"/> Advise on communications capabilities and limitations. <input type="checkbox"/> Establish telephone, communication links, and public address systems. <input type="checkbox"/> Establish clear and widespread communication throughout the incident. 	<ul style="list-style-type: none"> <input type="checkbox"/> Arrange and provide response personnel with first aid and minor medical services. <input type="checkbox"/> Develop Incident Medical Plan. <input type="checkbox"/> Develop procedures for handling serious injuries of responder personnel. <input type="checkbox"/> Provide medical aid to personnel. <input type="checkbox"/> Assist the Finance / Administration Section with processing injury-related claims. <p><i>Note: Provision of medical assistance to the public or victims of the emergency is an operational function and would be done by the Operations Section Medical Unit. If there is a requirement for victims of an incident the local public ambulance service is most often utilized.</i></p>	<ul style="list-style-type: none"> <input type="checkbox"/> Responsible for supplying the food needs for the entire incident, including all remote locations (e.g., Camps, Staging Areas), as well as providing food for personnel unable to leave tactical field assignments. <input type="checkbox"/> Works with the Planning Section - Resources Unit to anticipate the numbers of personnel to be fed and develop plans for supplying food to all incident areas. <input type="checkbox"/> Interacts with the Facilities Unit for location of fixed-feeding site; the Supply Unit for food ordering; and the Ground and Air Support Units for transporting food. <input type="checkbox"/> Obtain necessary equipment and supplies and establish cooking facilities. <input type="checkbox"/> Order sufficient food and potable water from the Supply Unit. <input type="checkbox"/> Maintain inventory of food and water. <input type="checkbox"/> Maintain food services areas, ensuring that all appropriate health and safety measures and being followed. <input type="checkbox"/> Supervise caterers, cooks, and other Food Unit personnel as appropriate. 	<ul style="list-style-type: none"> <input type="checkbox"/> Order, receive, distribute and track all incident equipment and supplies. <input type="checkbox"/> Ordered all off-incident resources including: tactical and support resources (including personnel), all expendable and non-expendable support supplies. <input type="checkbox"/> Management of tool operations, including the storage, disbursement, and service of all tools and portable non-expendable equipment. 	<ul style="list-style-type: none"> <input type="checkbox"/> Set-up, maintain, and demobilize incident support facilities with the exception of staging areas. <input type="checkbox"/> Facilities may include: Incident Command Post, Incident Base, Camps, and other facilities within the incident area to be used for feeding, sleeping and sanitation services. <input type="checkbox"/> Prepare layout of facilities; inform appropriate unit leaders. <input type="checkbox"/> Will provide security services to the incident as needed. <input type="checkbox"/> Contact local law enforcement agencies as required. <input type="checkbox"/> Investigate and document all complaints and suspicious occurrences. <input type="checkbox"/> Ensure strict compliance with applicable safety regulations. <input type="checkbox"/> Provide facility maintenance services, e.g., sanitation, lighting, etc. <input type="checkbox"/> Demobilize base and camp facilities. 	<ul style="list-style-type: none"> <input type="checkbox"/> Responsible for the maintenance, service and fuelling of all mobile equipment and vehicles, with the exception of aviation resources. <input type="checkbox"/> Coordinates the transportation of all personnel, supplies, and equipment. <input type="checkbox"/> Update the Resources Unit with the status (location and capability) of transportation vehicles. <input type="checkbox"/> Develop the Incident Traffic Plan as required.
<p style="text-align: center;">Important</p> <p>Prior to beginning any activities, each person in a role must:</p> <ul style="list-style-type: none"> <input type="checkbox"/> Obtain a completed ICS 201 Incident Briefing and ICS 207 Incident Organization Chart from the Incident Commander. <p>Throughout the duration of the incident, each person in a role must:</p> <ul style="list-style-type: none"> <input type="checkbox"/> Chronologically document all actions, decisions, contacts and requests on an ICS 214 Activity Log. Copies can be found in Section 6: Forms. <p>After the incident is over, each person in a role must:</p> <ul style="list-style-type: none"> <input type="checkbox"/> Assist with post-incident activities. <p style="text-align: center; color: red;">All forms referenced can be found in Section 6: Forms</p>						

All team members are located at the Incident Command Post (ICP), unless otherwise noted.

Revised October 2018

Escalate, Downgrade or Stand-Down Levels of Emergency: As the emergency is brought under control, the decision to downgrade the level and/or stand down the emergency will be based on air monitoring readings in consultation with the **Incident Commander** and the applicable government regulator. All affected persons and the media must be kept informed of the status of an emergency. **Emergency Follow-up:** Once the emergency is over, the area residents, transients, industrial users, involved government agencies, and any individual notified will be informed of the stand-down by the **Information Officer** or **Public Safety Group Supervisor**.

General Staff Roles – Finance / Admin Section

Finance / Admin Section Chief	Time Unit	Procurement Unit	Compensation & Claims Unit	Cost Unit
<p>The Finance / Administration Section Chief is responsible for managing all financial aspects of an incident. The Finance / Administration Section Chief will determine the need to activate or deactivate a unit.</p>	<p>The Time Unit is responsible for ensuring the accurate recording of daily personnel time, compliance with specific agency time recording policies and managing commissary operations if established at the incident.</p>	<p>All financial matters pertaining to vendor contracts, leases and fiscal agreements are managed by the Procurement Unit. The unit is also responsible for maintaining equipment time records. The Procurement Unit establishes local sources for equipment and supplies; manages all equipment rental agreements; and processes all rental and supply fiscal document billing invoices.</p>	<p>This unit oversees the completion of all forms required by workers' compensation and local agencies. A file of injuries and illnesses associated with the incident will also be maintained and all witness statement will be obtained in writing. Close coordination with the medical Unit is essential. The Compensation & Claims Unit is also responsible for investigating all claims involving property associated with or involved in the incident.</p>	<p>The Cost Unit provides all incident cost analysis. It ensures the proper identification of all equipment and personnel requiring payment; records all cost data; analyzes and prepares estimates of incident costs; and maintains accurate records of incident costs.</p>
<ul style="list-style-type: none"> <input type="checkbox"/> Identify and confirm communication links. <input type="checkbox"/> Assign personnel to assume the following positions, as required: Time Unit, Procurement Unit, Compensation & Claims Unit, and Cost Unit. <input type="checkbox"/> Review legal issues with the Incident Commander and EOC Director. <input type="checkbox"/> Maintain continuous communications with the Incident Commander. <input type="checkbox"/> Brief agency administrative personnel on all incident-related financial issues needing attention or follow-up. <input type="checkbox"/> Manage all financial aspects of an incident. 	<ul style="list-style-type: none"> <input type="checkbox"/> Record daily personnel time, ensure compliance with specific agency time recording policies, and manage commissary operations if established at the incident. <input type="checkbox"/> Submit cost estimate data forms to Cost Unit as required. <input type="checkbox"/> Ensure that all records are current and complete prior to demobilization. 	<ul style="list-style-type: none"> <input type="checkbox"/> Manage finances relating to vendor contracts, leases and fiscal agreements. <input type="checkbox"/> Maintain equipment time records. <input type="checkbox"/> Establish local sources for equipment and supplies. Coordinate with local jurisdiction on plans and supply sources. <input type="checkbox"/> Manage all equipment rental agreements. Establish contracts and agreement with supply vendors. <input type="checkbox"/> Processes all rental and supply fiscal document billing invoices. <input type="checkbox"/> Prepare and authorize contracts and land use agreements, as needed. 	<ul style="list-style-type: none"> <input type="checkbox"/> Handle all matters relating to compensation for injury or property damage due to the incident. <input type="checkbox"/> Oversees the completion of all forms required by workers' compensation and local agencies. <input type="checkbox"/> Maintain a file with all the injuries and illnesses associated with the incident. <input type="checkbox"/> Obtain witness statements in writing. <input type="checkbox"/> Investigate all claims involving property associated with or involved in the incident. <input type="checkbox"/> Ensure the completion of a Resident Compensation Log for any out-of-pocket expenses incurred by evacuees. Form B2 <input type="checkbox"/> All claims must be submitted to the Finance and Legal departments for processing and disbursement of funds. <input type="checkbox"/> If applicable, Finance and Legal will deal with insurers as well as any other extraneous circumstances (affected parties want more, etc.). 	<ul style="list-style-type: none"> <input type="checkbox"/> Collect and evaluate cost data to establish an accurate picture of the incident costs. <input type="checkbox"/> Create cost summaries, cost estimates, and cost saving recommendations. <input type="checkbox"/> Prepare resources-use cost estimates for the Planning Section. <input type="checkbox"/> Identify all equipment and personnel requiring payment.

Important

Prior to beginning any activities, each person in a role must:

- Obtain a completed ICS 201 Incident Briefing and ICS 207 Incident Organization Chart from the **Incident Commander.**

Throughout the duration of the incident, each person in a role must:

- Chronologically document all actions, decisions, contacts and requests on an ICS 214 Activity Log. Copies can be found in **Section 6: Forms.**

After the incident is over, each person in a role must:

- Assist with post-incident activities.

All forms referenced can be found in Section 6: Forms

All team members are located at the Incident Command Post (ICP), unless otherwise noted.

Revised October 2018

Escalate, Downgrade or Stand-Down Levels of Emergency: As the emergency is brought under control, the decision to downgrade the level and/or stand down the emergency will be based on air monitoring readings in consultation with the **Incident Commander** and the applicable government regulator. All affected persons and the media must be kept informed of the status of an emergency. **Emergency Follow-up:** Once the emergency is over, the area residents, transients, industrial users, involved government agencies, and any individual notified will be informed of the stand-down by the **Information Officer** or **Public Safety Group Supervisor.**

Operations Section - Public Safety Roles

Public Safety Group Supervisor	Air Monitors	Reception Centre Rep	Roadblocks	Rovers	Telephoners	
<p>The Public Safety Group Supervisor is responsible for the management, planning, consideration, and implementation of external public protection activities for the duration of the incident.</p>	<p>Air Monitoring personnel are responsible for acquiring and providing air quality readings to the Public Safety Group Supervisor.</p>	<p>Reception Centre Reps are responsible for establishing reception centres, managing evacuee accommodation, communication and documentation for compensation purposes.</p>	<p>Roadblock personnel are responsible for restricting unauthorized entry into the hazard areas during an incident that could potentially jeopardize public safety.</p>	<p>Rovers travel to assigned locations to locate the public and personally provide public safety instructions and assistance as required. This may be completed via truck, ATV, boat, helicopter, etc.</p>	<p>Telephoners are responsible for the notification of impacted residences and businesses to provide public safety instructions.</p>	
<ul style="list-style-type: none"> <input type="checkbox"/> Confirm communication links with the Incident Commander and Operations Section Chief. <input type="checkbox"/> In conjunction with the Incident Commander: determine the size of the EPZ; identify the residents, businesses, industrial operators, and / or transients in the area; and determine the initial public protection measures to be taken. Consider the impact of major highways, navigable water courses, cleared pipeline rights of way & railways in the hazard area. Refer to Section 4: Emergency Response Procedures for guidelines on evacuation / shelter, ignition, roadblocks, rovers, public concerns, etc. Additional information for Air Monitors, Reception Centre Representative, Roadblocks, Rovers, and Telephoners can be found in Section 2: Roles & Responsibilities. <input type="checkbox"/> In conjunction with the Incident Commander, Planning Section Chief, and Operations Section Chief, develop and implement an Incident Action Plan (IAP). <input type="checkbox"/> Review resident lists, area user lists, reception centres, and telephone numbers within the ERP. <input type="checkbox"/> If required, establish a Regional Emergency Operations Centre (REOC). <input type="checkbox"/> Assign personnel to assume the following positions as required: Air Monitors, Reception Centre Representative, Roadblocks, Rovers, and Telephoners. <ul style="list-style-type: none"> <input type="checkbox"/> The Telephoners must have sufficient personnel to accommodate the following ratios when contacting residents: 1 Telephoner to every 7 residences; and 1 Supervisor for every 10 Telephoners. <input type="checkbox"/> Dispatch Air Monitors at a Level 1 emergency (hand-held and mobile). <ul style="list-style-type: none"> <input type="checkbox"/> Dispatch trained personnel with the appropriate hand-held gas monitors to record concentrations of LEL and H₂S at the nearest un-evacuated residences downwind of the incident site. <input type="checkbox"/> Mobilize third party mobile air monitoring units which can measure in parts per billion (ppb) <input type="checkbox"/> Maintain communication with the applicable government regulator and environment agency regarding air monitoring needs and activities. <input type="checkbox"/> Consult with the Operations Section Chief to determine the need for evacuation / sheltering. This is based on air monitoring readings at the nearest downwind residence. <input type="checkbox"/> Prioritize public closest to, downwind, those that have requested early notification, and those with special needs to establish the order of evacuation. Coordinate evacuation or shelter of residents, area users, and transients (via Telephoners and Rovers). <ul style="list-style-type: none"> <input type="checkbox"/> Determine who needs to be notified and what script will be used: Early Notification / Voluntary Evacuation Message, Shelter-in-Place Phone Message, Evacuation Phone Message. Form B6 Form B7 Form B8 <input type="checkbox"/> At a Level 1 Emergency it is required to notify any special needs residents and give them the option to evacuate. <input type="checkbox"/> If residences are evacuated, a reception centre must be established. <input type="checkbox"/> Determine and notify landowner / occupant(s) as soon as possible. <input type="checkbox"/> Ensure the schools / school buses are contacted to make arrangements for school age children (if applicable). <input type="checkbox"/> If a large number of people need to be evacuated (large industrial operations and/or public facilities) refer to the Area Specific Information section (white tabs) for contacts to obtain charter buses or changes to the normal notification procedures. <input type="checkbox"/> Send Rovers (if required) to identify human activity in the area which is not already identified within the ERP (drilling, pipeline construction, logging, hunting, farming, camping, fishing, etc.). <input type="checkbox"/> Prepare Evacuation Notices and provide copies to Rovers. Form B5 <input type="checkbox"/> Rovers can be used to assist with notifications, assist with evacuating special needs residents, assist with air monitoring, etc. <input type="checkbox"/> Continually assess the need for additional evacuation, shelter or ignition based on air monitoring readings. <input type="checkbox"/> Determine the need for helicopters to identify human activity in the area. <input type="checkbox"/> Determine the need for and location of Roadblocks to isolate and secure the area. <ul style="list-style-type: none"> <input type="checkbox"/> Dispatch trained personnel with the appropriate equipment to establish roadblocks on the roads entering/exiting the hazard area. <input type="checkbox"/> Contact the RCMP & Ministry of Transportation for permission to close 1, 2, or 3 digit provincial or secondary highways. <input type="checkbox"/> Assess and expand the incident response to include those outside of the EPZ if required by air monitoring readings. Coordinate public protection measures outside the EPZ with the local authority. <input type="checkbox"/> Ensure security of evacuated homes, at roadblocks, and at the reception centre. <input type="checkbox"/> Regularly update the Incident Commander. <input type="checkbox"/> Confirm communication links with: Air Monitors, Reception Centre, Roadblocks, Rovers, and Telephoners. Personnel should check in at scheduled intervals. <input type="checkbox"/> Review and confirm evacuation of residents, area industrial users, transients, etc. from the area. <input type="checkbox"/> Request that a Notice to Airmen (NOTAM) is issued to restrict the airspace above the EPZ. 	<ul style="list-style-type: none"> <input type="checkbox"/> Provide air monitoring readings to assist with decision making (evacuation / shelter / ignition). <input type="checkbox"/> Obtain and check equipment and information (maps, forms, communications, reports, monitors, safety, and breathing equipment). <input type="checkbox"/> Confirm communication links. <input type="checkbox"/> Monitor closest downwind public location or residence. <input type="checkbox"/> Monitor environment for adverse effects. <ul style="list-style-type: none"> <input type="checkbox"/> Record all readings on the Air Monitoring Log. Form A5 <input type="checkbox"/> Report all readings at established intervals to the Public Safety Group Supervisor. <input type="checkbox"/> For your own safety, ensure Public Safety Group Supervisor is notified immediately if readings are approaching 10% LEL and / or 10 ppm H₂S. <ul style="list-style-type: none"> <input type="checkbox"/> Prepare Mobile Monitoring Plan. Form A5 	<p style="text-align: center;">Important</p> <p>Prior to beginning any activities, each person in a role must:</p> <ul style="list-style-type: none"> <input type="checkbox"/> Obtain a completed ICS 201 Incident Briefing and ICS 207 Incident Organization Chart from the Incident Commander. <p>Throughout the duration of the incident, each person in a role must:</p> <ul style="list-style-type: none"> <input type="checkbox"/> Chronologically document all actions, decisions, contacts and requests on an ICS 214 Activity Log. Copies can be found in Section 6: Forms. <p>After the incident is over, each person in a role must:</p> <ul style="list-style-type: none"> <input type="checkbox"/> Assist with post-incident activities. <p style="text-align: center;">All forms referenced can be found in Section 6: Forms</p>	<ul style="list-style-type: none"> <input type="checkbox"/> Confirm reception centre is available for use. <input type="checkbox"/> Establish reception centre. Refer to Section 2: Roles & Responsibilities. <input type="checkbox"/> Confirm communication links. <input type="checkbox"/> Receive evacuees and maintain a Reception Centre Registration Log. Form B1 <input type="checkbox"/> Arrange for food and accommodations for the evacuees. <ul style="list-style-type: none"> <input type="checkbox"/> Provide evacuees with a place to request counselling services, if required. <input type="checkbox"/> Record and follow up on all evacuees who choose to make their own accommodation arrangements. <input type="checkbox"/> Arrange for temporary care of livestock (if possible) and the security of evacuated property. <input type="checkbox"/> Establish and oversee compensation administration activities at the reception centre. <ul style="list-style-type: none"> <input type="checkbox"/> Reimburse evacuees for their immediate out-of-pocket expenses and log details on a Resident Compensation Log. Form B2 <input type="checkbox"/> Where possible, provide evacuees with information regarding their property, livestock, and the incident. <input type="checkbox"/> Forward all media and incident inquiries to the Information Officer. <input type="checkbox"/> Report all names of evacuees who have registered at the reception centre to the Public Safety Group Supervisor. <input type="checkbox"/> Address resident concerns and forward them to the Public Safety Group Supervisor. 	<ul style="list-style-type: none"> <input type="checkbox"/> In conjunction with the Public Safety Group Supervisor determine the need for and location of roadblocks. <input type="checkbox"/> Pickup and check roadblock kits. <input type="checkbox"/> Proceed to roadblock locations. <input type="checkbox"/> Determine driving directions to assigned roadblock location that does not have you pass through the hazard area. <input type="checkbox"/> Confirm communication links. <input type="checkbox"/> Establish roadblocks to secure the EPZ. <input type="checkbox"/> Follow the scripts and procedures in the ERP. Refer to either Section 2: Roles & Responsibilities or Section 6: Forms. <ul style="list-style-type: none"> <input type="checkbox"/> If media personnel show up at your roadblock, forward all requests to your direct supervisor who'll direct them to the Information Officer. Form A5 <input type="checkbox"/> Monitor area for H₂S and / or LEL with personal monitors and document readings on the Air Monitoring Log. Form A5 <input type="checkbox"/> Report all H₂S and / or LEL reading changes / increases to the Public Safety Group Supervisor. <input type="checkbox"/> For your own safety, ensure the Public Safety Group Supervisor is notified immediately if readings are approaching 10% LEL and / or 10 ppm H₂S. <ul style="list-style-type: none"> <input type="checkbox"/> Record all incoming and outgoing traffic, personnel, and equipment on the Roadblock Log. Form B4 <input type="checkbox"/> Forward information given to you by people passing through your location to the Public Safety Group Supervisor. <input type="checkbox"/> Report any person that insists on going through the roadblock into the hazard area as well as any suspicious activity to the Public Safety Group Supervisor. <input type="checkbox"/> Maintain communication with the Public Safety Group Supervisor. <input type="checkbox"/> Maintain roadblock locations. Do not leave until requested to do so by the Public Safety Group Supervisor or until relieved by other Roadblock personnel. <p><i>Note: See Section 2: Roles & Responsibilities for a media script for Roadblock and Rover personnel.</i></p>	<ul style="list-style-type: none"> <input type="checkbox"/> Confirm resident contact lists are available. <input type="checkbox"/> Confirm communication links. <input type="checkbox"/> Know safe routes in and out of the EPZ. <input type="checkbox"/> Search for residents and transients in the Emergency Response and Planning Zones. <input type="checkbox"/> Check all buildings including barns, shops, sheds, etc. <input type="checkbox"/> Assist, as required, with the notification, evacuation or sheltering of persons within the EPZ. Record all contact with residents using the Resident Contact Log. Form B3 <input type="checkbox"/> Post Evacuation Notices for residents that are not at their residence. Form B5 <input type="checkbox"/> Follow the scripts and procedures in the ERP. Refer to Section 2: Roles & Responsibilities or Section 6: Forms. <input type="checkbox"/> Monitor area for H₂S and / or LEL with personal monitors and document readings on the Air Monitoring Log. Form A5 <input type="checkbox"/> Report all H₂S and / or LEL reading changes / increases to the Public Safety Group Supervisor. <input type="checkbox"/> For your own safety, ensure the Public Safety Group Supervisor is notified immediately if readings are approaching 10% LEL or 10 ppm H₂S. <input type="checkbox"/> Report any suspicious behaviour to the Public Safety Group Supervisor who will notify the police as required. <input type="checkbox"/> Maintain communication with the Public Safety Group Supervisor. <p><i>Note: See Section 2: Roles & Responsibilities for a media script for Roadblock and Rover personnel.</i></p>	<ul style="list-style-type: none"> <input type="checkbox"/> Confirm resident contact lists are available. <input type="checkbox"/> Confirm communication links. <input type="checkbox"/> In conjunction with the Public Safety Group Supervisor, determine who needs to be notified (residents, businesses, area users, etc.). <input type="checkbox"/> Review with the Public Safety Group Supervisor which telephoner scripts to use: Early Notification / Voluntary Evacuation Message, Shelter-in-Place Phone Message, Evacuation Phone Message. Form B6 Form B7 Form B8 <input type="checkbox"/> Contact special needs residents at a Level 1 Emergency and provide them with the option to evacuate. <input type="checkbox"/> Contact the other residents and area users in the EPZ and advise them to evacuate or shelter. <input type="checkbox"/> Contact the schools / school buses to make arrangements for school age children (if applicable). <ul style="list-style-type: none"> <input type="checkbox"/> Advise that buses in the affected area leave immediately and that buses should not enter the area. <input type="checkbox"/> Request a school administrator for the reception centre to assist in managing the children and releasing them to their guardians. Form B3 <input type="checkbox"/> Document all resident interactions using the Resident Contact Log and report this information to the Public Safety Group Supervisor. Immediately advise the Public Safety Group Supervisor about unsuccessful contacts and any residents requiring assistance.
<p>Located at the Incident Command Post (ICP) or the Regional Emergency Operations Centre (REOC).</p>	<p>Location will be assigned.</p>	<p>Location will be the reception centre.</p>	<p>Location will be assigned.</p>	<p>Location will be assigned.</p>	<p>Location will be Incident Command Post (ICP) or Regional Emergency Operations Centre (REOC).</p>	

Escalate, Downgrade or Stand-Down Levels of Emergency: As the emergency is brought under control, the decision to downgrade the level and/or stand down the emergency will be based on air monitoring readings in consultation with the **Incident Commander** and the applicable government regulator. All affected persons and the media must be kept informed of the status of an emergency. **Emergency Follow-up:** Once the emergency is over, the area residents, transients, industrial users, involved government agencies, and any individual notified will be informed of the stand-down by the **Information Officer** or **Public Safety Group Supervisor**.

Overview

H₂S, SO₂, LEL or other toxic substance concentrations will be monitored continuously during the incident response. It is crucial that **Air Monitors** continuously update the **Public Safety Group Supervisor** with monitored results. If air monitoring readings show high levels of H₂S, SO₂, or LEL the **Public Safety Group Supervisor** may need to initiate evacuation / shelter of additional residences, change the location of the roadblocks, or ignite the release.

Air Monitor Roles

- Obtain and check equipment and information (maps, forms, communications, reports, monitors, safety, and breathing equipment).
- Confirm communication links.
- Monitor closest downwind public location or residence.
- Monitor environment for adverse effects. Form A5
- Record all readings on the Air Monitoring Log provided.
- Report all readings at established intervals to the **Public Safety Group Supervisor**.
- For your own safety, ensure the **Public Safety Group Supervisor** is notified immediately if readings are approaching the following levels: 10% LEL or 10 ppm H₂S.
- Prepare Mobile Monitoring Plan.
- Document activities using the ICS 214 Activity Log. Form ICS 214
- Assist with post-incident activities.
- Monitor H₂S and LEL concentrations along the edge of the EPZ to determine if sheltering and/or evacuation criteria has been met beyond the EPZ.

Air Monitoring Equipment

Air monitoring equipment is used to:

- Track the plume.
- Determine if ignition criteria are met.
- Determine whether evacuation and / or shelter-in-place criteria have been met.
- Determine roadblock locations.
- Determine concentrations in areas being evacuated to ensure that evacuation is safe.
- Assist in determining when the emergency can be downgraded.

Tips

- Air monitors should be dispatched at a Level 1 Emergency.
- Ensure all equipment is operational and the appropriate documentation is available to verify testing and calibration requirements.
- Use the buddy system where possible.
- Breathing apparatus – be prepared to don apparatus quickly.
- Ensure all personnel have a personal gas monitor.
- Speed and direction of wind may vary, therefore, be prepared to track gas plume.
- Record all information:
 - Concentrations in ppm or ppb
 - Location and time of readings
 - Wind speed and direction

Regulatory Requirements

Drilling & Completions

Critical / Special Sour Wells

If the EPZ includes a portion of urban density development or urban centre:

- There must be minimum of two mobile air monitors:
 - One to monitor the boundary of the urban density development or urban centre and the other to track the plume.
- Ensure that one unit is in the area during drilling and / or completion, testing, and workover operations in potentially critical sour zones.
- Dispatch a mobile air quality monitoring unit(s) at a level 1 emergency and request additional units as required.
- Dispatch a mobile air quality monitoring unit(s) when it is evident that well control measures are deteriorating and that a sour gas release is likely to occur.
- Prior to conducting operations in the sour zone, determine where the monitoring equipment is located and what the estimated travel time is to the well site.

If the EPZ **DOES NOT** include a portion of urban density development or urban centre:

- Dispatch a mobile air quality monitoring unit(s) at a level 1 emergency and request additional units as required.
- Dispatch a mobile air quality monitoring unit(s) when it is evident that well control measures are deteriorating and that a sour gas release is likely to occur.
- Prior to conducting operations in the sour zone, determine where the monitoring equipment is located and what the estimated travel time is to the well site.

Continuous Detection Devices

A continuous H₂S/LEL system must be used while in the critical sour zone. The detection system requirements are as follows:

- A minimum of four sensors able to detect H₂S concentrations of 5 ppm or greater.
- Audible and visual alarms near the driller's station.
- Set alarms at 10 ppm.
- Locate sensors at the shale shaker, near the bell nipple, on the rig floor, and at the mud mixing unit.

Portable Detection Devices

- One portable H₂S detection device is required while drilling in the critical sour zone.

Production Operations & General Information

Sour Gas Release

- If notified of a release by alarm or by a reported odour, the licensee must investigate the source of the release and dispatch air monitors upon confirmation of the release location or when it is evident that spill control measures are not effective.
- Air quality monitoring occurs downwind with priority being directed to the nearest un-evacuated residence or area where people may be present.
- Air monitors (personal handheld, stationary, and mobile) should be dispatched at a level 1 emergency.
- Dispatch a mobile air quality monitoring unit(s) when it is evident that spill control measures are not effective and that a sour gas release is likely to occur.
- Licensee personnel will monitor and record the concentrations until a mobile air monitoring unit arrives or until the incident is over. At minimum, these readings must include LEL and H₂S.
- If a sour gas release has been ignited, the licensee should continue to monitor response zones for H₂S from incomplete combustion, as well as SO₂.
- The licensee is expected to provide monitored H₂S and SO₂ information on a regular basis throughout a sour gas emergency to the relevant government regulator, environmental agency, health authority, local authorities, and on request to the public.

HVP Product Release

- Air quality monitoring may occur downwind or upwind depending on how the plume is tracking, with priority being directed to the nearest un-evacuated residence or areas where people may be present.
- The licensee is expected to provide monitored HVP product LEL information on a regular basis throughout the emergency to the relevant government regulator, environmental agency, health authority, local authorities, and on request to the public.

Downgrading Level of Emergency

- The decision to downgrade an incident will be based on the air monitoring results.

Air Monitoring Log - Example Form A5

Time	Location of Samples	H ₂ S (ppm)	LEL (%)	O ₂ (%)	SO ₂ (ppm)	Other	Temp (°C)	Wind Conditions *		Comments
								From	Speed (km/hr)	
19:06	12-05-13-16 W5M	5	4		10		19	NW	12	Picked up 5 ppm reading upon entering lease access. Contacted control room at plant.
19:15	12-05-13-16 W5M	6	7		12		18	NW	11	H ₂ S reading increased 1 ppm at the access point.
19:25	12-05-13-16 W5M	6	7		12		17	NW	11	No change in readings. Wind and temperature is down.

* Estimate meteorological conditions where accurate readings are not available.

1. Choosing a Position

1. Using your map and the current wind conditions, travel downwind, with priority being directed to the nearest un-evacuated residence or area where people may be present.
2. Confirm the location with the **Public Safety Group Supervisor** and make sure you have a safe route to the assigned location that does not cross the hazardous area.

2. Record Information

- Record information on the following forms located within this Section:
- Air Monitoring Log Form A5
 - ICS 214 Activity Log Form ICS 214

Reporting and Contacts

Air Monitors report to the **Public Safety Group Supervisor**.

Name:
 Phone Number:
 Reception Centre
 Location:
 Phone Number:
 Wind Direction:

Overview

In the event of an emergency in which residents need to be evacuated, a Reception Center must be established to receive and register the evacuees. A **Reception Center Representative** is assigned to manage / coordinate activities at the Reception Center. The **Reception Center Representative** continuously updates the **Public Safety Group Supervisor** with a list of those who have, and have not, checked in at the Reception Center.

Reception Center Rep Roles

- Confirm Reception Center is available for use.
- Establish Reception Center.
- Confirm communication links.
- Receive evacuees and maintain a Reception Center Registration Log. Form B1
- Arrange for food and accommodations for the evacuees.
- Provide evacuees with a place to request counselling services, if required.
- Record and follow up on all evacuees who choose to make their own accommodation arrangements. Form B2
- Arrange for temporary care of livestock (if possible) and the security of evacuated property.
- Establish and oversee compensation administration activities at the reception center.
- Reimburse evacuees for their immediate out-of-pocket expenses and log details on a Resident Compensation Log.
- Where possible, provide evacuees with information regarding their property, livestock, and the incident.
- Forward all media and incident inquiries to the **Information Officer**. Form C2
- Report all names of evacuees who have registered at the Reception Center to the **Public Safety Group Supervisor**.
- Document activities using the ICS 214 Activity Log. Form ICS 214
- Assist with post-incident activities.
- Confirm information to be released to public with the **Information Officer**.
- Address resident concerns and forward them to the **Public Safety Group Supervisor**.

1. Choosing a Reception Center

- Reception Centers are usually located in schools, hotels / motels, or community halls.
- It may be useful to coordinate the location of the Reception Center with the local authority (city, town, county, state etc.).
- See Area Specific Information (white tabs) for pre-identified Reception Centers in your area.

A Reception Center should:

- Have a conference room of some type where a large number of people can gather.
- Have conferencing services including fax machine, internet access, and phone access.
- Be large enough to house all of the evacuees.
- Be outside of the hazard area.
- Allow residents to evacuate to the Reception Center without travelling through the hazard area.
- Allow pets.

Tips

- Ensure you have enough staff to handle the needs of all of the evacuees.
- Allow evacuees to vent their emotions.
- Do not make any promises that cannot be kept.
- Attempt to reunite families as quickly as possible.
- Document the details of anyone who may have trouble coping with the incident so that they can be given proper psychological support.
- Monitor whether residents that have been contacted by the **Telephoners, Rovers, and Roadblock** personnel have checked in at the Reception Center.

2. Reception Center Feedback Loop

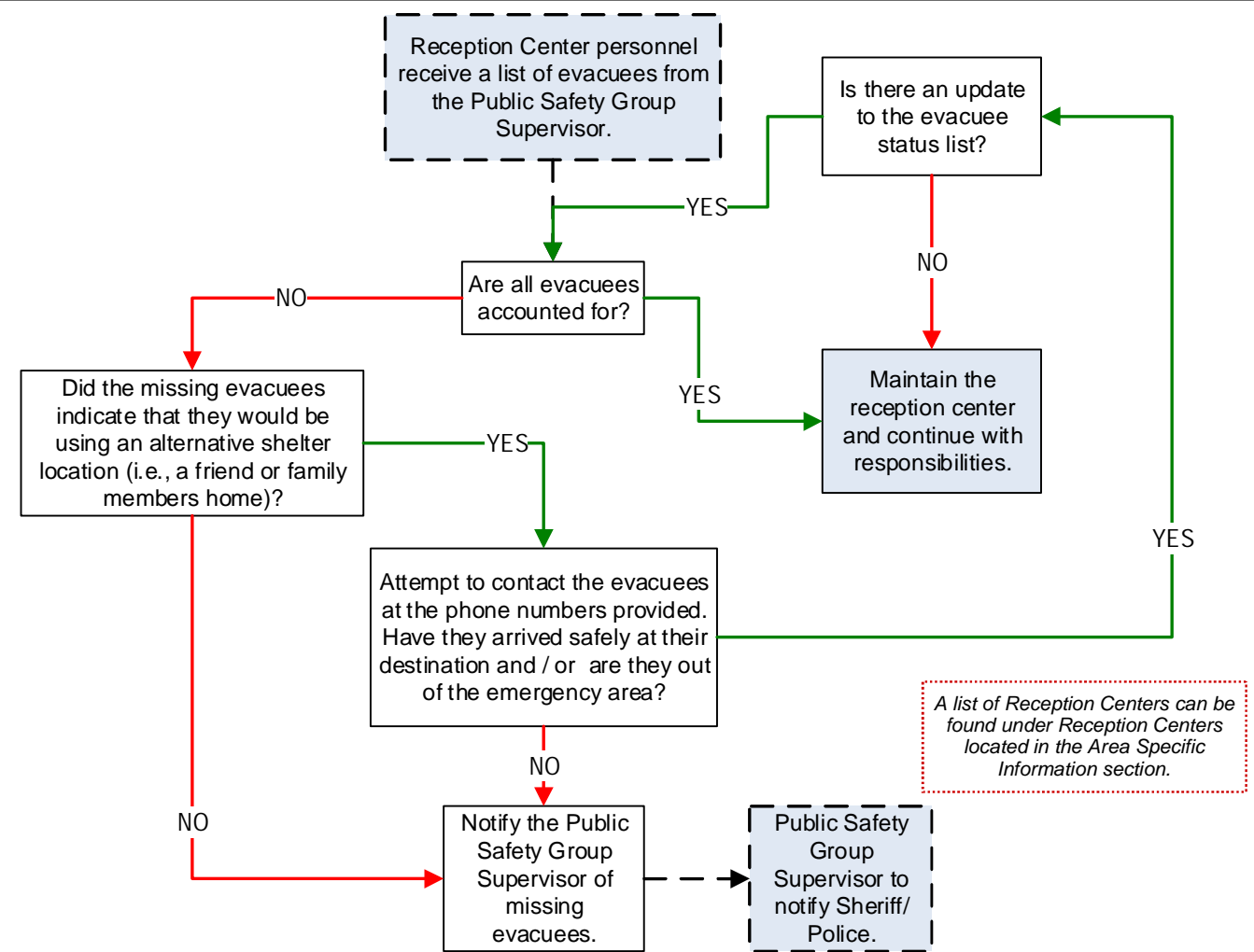

Reception Center Registration Log - Example

Resident ID	Name (List all names in party)		# of Occupants	Number Arrived	Arrival Time	Depart Time	Destination Phon # (Where they can be reached)	Comments
	First	Last						
G124-A	John	Doe	2	2	19:06	19:21	555-555-5555	John and his wife arrived safely then left to stay at a friend's house in Red Deer.
H131-B	Jane	Doe	3	3	19:12	19:28	555-555-5555	Jane and her 2 children arrived safely then left to stay with her mother in Bentley.
F122-A	James	Doe	5	3	19:20		555-555-5555	James, his wife and 1 child arrived safely. The other two children are away on a school trip. They will stay at the reception center for the night.

Media Statement

Refer all media inquiries to the Media Representative. However, if they insist on a statement, please use the following:

“We are currently dealing with the situation at hand to ensure the safety of the public, our personnel, and the environment. A statement will be released by the company once the facts have been determined. If you would like to leave your business card or phone number, a company representative will provide you with more information as it becomes available.”

Note: See Section 3.0 Communication & Media for more information on media.

3. Record Information

Record information on the following forms located within this Section:

- Reception Center Registration Log
- Resident Compensation Log
- ICS 214 Activity Log
- Media Contact Log

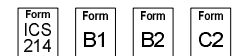

Reporting and Contacts

Reception Center Reps report to the **Public Safety Group Supervisor**.

Name: _____

Phone Number: _____

Reception Center

Location: _____

Phone Number: _____

Wind Direction: _____

Overview

In the event of an emergency, roadblock locations and road detours will be established. The company will initially establish and maintain roadblocks until relieved by highway maintenance contractors or the RCMP. **Roadblock** personnel will be assigned in teams of two, one member to stop approaching traffic, the other will record the information gathered and relay to The Public Safety Group Supervisor. The **Public Safety Group Supervisor** must be continuously updated by **Roadblock** personnel so that all vehicles entering and exiting the EPZ are accounted for.

Roadblock Personnel Roles

- In conjunction with the **Public Safety Group Supervisor**, determine the need for and location of roadblocks.
- Pickup and check roadblock kits.
- Proceed to roadblock locations.
- Determine driving directions to assigned roadblock location that does not have you pass through the hazard area.
- Confirm communication links and establish communication interval times.
- Establish roadblocks to secure the EPZ.
- Follow the scripts and procedures in the ERP.
- If media personnel show up at your roadblock, forward all requests to your direct supervisor who'll direct them to the **Information officer** or **Corporate Comm/Media team**.
- Knowledge and ability to communicate safest route away from hazard.
- Monitor area for H₂S and / or LEL with personal monitors and document readings on the Air Monitoring Log. Form A5
- Report all reading changes / increases to the **Public Safety Group Supervisor**.
- For your own safety, ensure the **Public Safety Group Supervisor** is notified immediately if readings are approaching 10% LEL and / or 10 ppm H₂S.
- Move location of Roadblock immediately if readings are approaching 10% LEL and / or 10 ppm H₂S. Form B4
- Record all incoming and outgoing traffic, personnel, and equipment on the Roadblock Log.
- Forward information given to you by people passing through your location to the **Public Safety Group Supervisor**. Form ICS 214
- Document activities using the ICS 214 Activity Log.
- Report any person that insists on going through the roadblock into the hazard area as well as any suspicious activity to the **Public Safety Group Supervisor**.
- Maintain communication with the **Public Safety Group Supervisor**.
- Maintain roadblock locations. Do not leave until requested to do so by the **Public Safety Group Supervisor** or until relieved by other **Roadblock** personnel.
- Assist with post-incident activities.

Roadblock Kit Contents - Sample

- The roadblock kit may contain the following items:
- Recommended**
- Direct communication capability (radio, cell phone, etc.)
 - ERP maps and roadblock forms
 - Flashlight and batteries
 - High visibility / reflective vests
 - Orange traffic cones / reflectors
 - Pens and / or pencils
 - Personal Air Monitoring Device (H₂S, CO, O₂, LEL)
 - Portable rotating emergency light
 - SCBA
 - Hand-held stop sign with reflective tape
 - Waterproof bag
- Optional**
- Caution tape
 - Rain suit
 - Road barrier

Tips

- When talking to motorists at the roadblock, **ONLY** provide them with the information as directed by the **Public Safety Group Supervisor**.
- Ask for identification prior to granting access.
- You do not have the legal authority to restrict access to the area without an order from the relevant authority. Report any person who chooses to proceed, without permission, through the roadblock.
- Check with the motorists and ensure all members of their residence are accounted for and documented on the Resident Contact Log. Report any resident that is left behind in the EPZ. Form B3
- The roadblock should be setup to allow optimal visibility and sufficient distance for traffic to come to a safe and complete stop.
- Roadblock** personnel should be highly visible on the side of the road and have an escape route in case of an emergency.
- DO NOT** leave your position until you are directed to do so.

1. Choosing a Roadblock

- Roadblocks should be established:
 - Approximately where the EPZ intersects any highways / roads.
 - Outside of the hazard area.
 - At a conspicuous location where the **Roadblock** personnel will be visible to approaching traffic, providing them with enough time to safely stop.
 - At a location where traffic can easily turn around or detour (consider the potential for larger vehicles such as buses, semi-trailers, drilling rigs, etc.).
 - Where possible at natural roadblock locations (e.g., gates, bridges, junctions, etc).

2. Before Departure

- Make sure your vehicle is equipped and suitable for the travel conditions.
- Check roadblock kit to confirm all items are present (see sample of roadblock kit contents to left).
- Confirm that your handheld monitor for H₂S and / or LEL is functioning properly.
- Check all communications devices.
- Check that the red signaling baton flashlight is working and has spare batteries.
- Confirm that you have enough copies of the Roadblock Log form.
- Confirm the location of the roadblock with the **Public Safety Group Supervisor** and make sure you have a safe route to the assigned location that does not cross the hazardous area.

3. Setting up a Roadblock

- Park vehicle as illustrated, activating four way flashers and roof mounted rotating beacon.
- Put on reflective vests.
- Take a reading with your handheld monitor for H₂S and / or LEL; ensuring your roadblock is not too close to the edge of the EPZ. Record readings on the Air Monitoring Log. Form A5
- Notify the **Public Safety Group Supervisor** once your roadblock is set up.
- Continue to monitor and record H₂S and / or LEL levels at scheduled intervals. Report to the **Public Safety Group Supervisor** at scheduled intervals.
- Maintain roadblock until the emergency is over and the "all clear" message is given or until relieved by other **Roadblock** personnel.

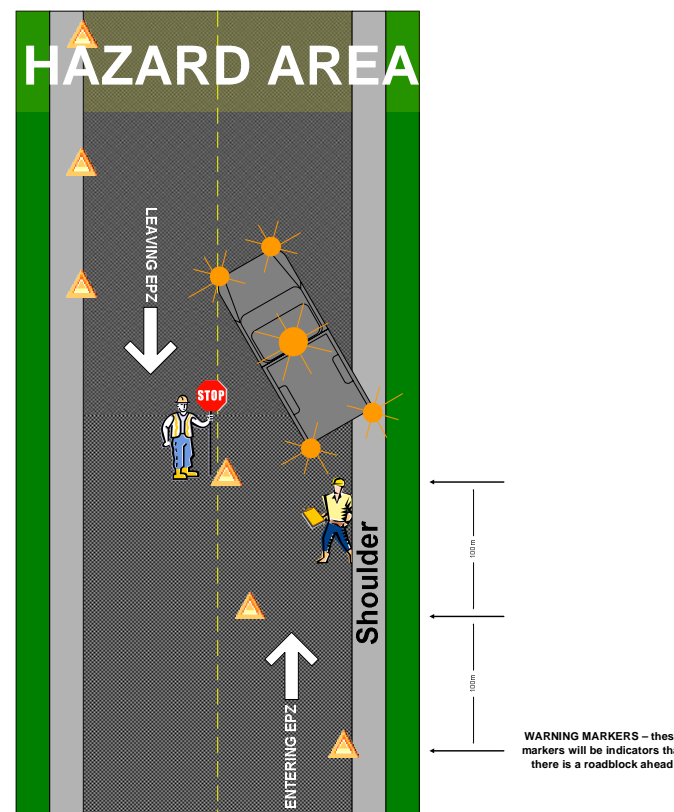

Reporting and Contacts

Roadblock personnel report to the **Public Safety Group Supervisor**.

Name: _____

Phone Number: _____

Reception Centre

Location: _____

Phone Number: _____

Wind Direction: _____

To give motorists time to prepare to come to a stop, it is recommended that the **Roadblock** personnel set up all available collapsible reflective triangles 100 metres apart, at a minimum distance of 200 metres before the roadblock.

Roadblock personnel cannot force an evacuation or restrict access to the area unless proper authority has been granted. The authority for forced evacuation is gained only through the declaration of a State of Local Emergency by the local authority.

When establishing a roadblock consider:

- Visibility
- Distance
- Bends in the road
- Level of the ground

Remember to:

- Remain calm
- Be courteous
- Record names
- Notify the **Public Safety Group Supervisor**

4. How to Stop Traffic

1. Hold the reflective stop / slow paddle erect and away from your body. Never wave the sign.
2. Look directly at the approaching driver.
3. Raise your free arm with the palm of your hand exposed to the driver.
4. Bring the vehicle to a full stop.
5. After the first vehicle has stopped, move to a spot (near the centre line of the roadway) where you can be seen by other approaching vehicles.

Because visibility is reduced at night, it is important that you use utmost care when stopping traffic through a roadblock area, and that you protect yourself from injury by:

- Standing in a safe position on the shoulder of the road.
- Waving the red signaling baton flashlight back and forth.

Note: The red signaling baton flashlight should only be used in place of the reflective stop / slow paddle at night or in conditions of low / poor visibility.

5a. Roadblock Script

"I am representing [Insert Company Name] and we are presently experiencing control problems ahead. This situation is serious enough to warrant restricted access beyond this point. For your own safety I must ask you not to proceed."

Note:

- ◆ Record driver's name, vehicle make, color, etc. and at least the license plate number of all vehicles approaching your roadblock; also make a note of the time and of the direction the vehicle took when leaving (e.g., east, south, west, north) on your log sheet.
- ◆ Remember you have no legal position to restrict access to the general public. You are there to protect and notify – to protect the health and safety of the people by notifying them of the danger and secondly to protect the property of the residents who have evacuated the area.
- ◆ Should someone continue into the restricted area, regardless of your warning about personal safety, then use the 2-way radio or cell phone to notify the **Public Safety Group Supervisor** and the matter shall be immediately turned over to the Police.

5b. Media Statement

If the media arrives at your roadblock location, company personnel may give the following statement:

"We are currently dealing with the situation at hand to ensure the safety of the public, our personnel, and the environment. A statement will be released by the company once the facts have been determined. If you would like to leave your business card or phone number, a company representative will provide you with more information as it becomes available."

Contact the **Public Safety Group Supervisor** if a media representative arrives at your roadblock.

NEVER offer your opinion of what is happening at the location to a media person or stranger. This can be interpreted as the company's position. **DO NOT** give statements, other than the above message, regarding the emergency situation to the MEDIA. Refer them to the Information Officer.

Be courteous but firm.

If the questioning persists, just keep politely repeating word for word the statement above.

6. Record Information

Record information on the following forms located within this section:

- Roadblock Log
- Resident Contact Log
- Air Monitoring Log
- ICS 214 Activity Log

Form ICS 214 Form A5 Form B3 Form B4

Possible Scenarios for Roadblock Personnel:

- ◆ Motorist obeys request and drives away from the EPZ.
- ◆ Motorist is leaving the EPZ and agrees not to return until further notice.
- ◆ Emergency responders (service companies, fire, ambulance, etc.) are entering the EPZ to help respond to the incident.
- ◆ Motorist disobeys request to leave the area and enters the EPZ.

In all cases, notify the **Public Safety Group Supervisor** and log all information.

Overview

Rovers are responsible for patrolling the Emergency Planning Zone to locate and notify residents, businesses, industrial operators, transients (i.e. hunters, trappers, recreational users, non-resident landowners), and the general public. This may be completed via truck, ATV, boat, helicopter, etc. The **Public Safety Group Supervisor** must be continuously updated by the **Rovers** so that unsuccessful attempts to evacuate residents, transients, etc. can be followed up on immediately.

Rover Personnel Roles

- Confirm resident contact lists are available.
- Confirm communication links.
- Know safe routes in and out of the EPZ.
- Search for residents and transients in the Emergency Planning and Response Zones.
- Check all buildings including barns, shops, sheds, etc.
- Assist, as required, with the notification, evacuation or sheltering of persons within the Emergency Planning Zone. Record all contact with residents using the Resident Contact Log. Form B3
- Post Evacuation Notices for residents that are not at their residence. Form B5
- Follow the scripts and procedures in the ERP.
- Monitor area for H₂S and / or LEL with personal monitors and document readings on the Air Monitoring Log. Form A5
- Report all reading changes / increases to the **Public Safety Group Supervisor**.
- For your own safety, ensure the **Public Safety Group Supervisor** is notified immediately if readings are approaching the following levels: 10% LEL and / or 10 ppm H₂S.
- Report any suspicious behaviour to the **Public Safety Group Supervisor** who will notify the police as required.
- Document all activities using the ICS 214 Activity Log. Form ICS 214
- Maintain communication with the **Public Safety Group Supervisor**.
- Assist with post-incident activities.

Media Statement

If a media representative approaches you, company personnel may give the following statement:

“We are currently dealing with the situation at hand to ensure the safety of the public, our personnel, and the environment. A statement will be released by the company once the facts have been determined. If you would like to leave your business card or phone number, a company representative will provide you with more information as it becomes available.”

Contact the **Public Safety Group Supervisor** if a media representative approaches you.

NEVER offer your opinion of what is happening at the location to a media person or stranger. This can be interpreted as the company's position. **DO NOT** give statements, other than the above message, regarding the emergency situation to the MEDIA. Refer them to the Information Officer.

Be courteous but firm.

If the questioning persists, just keep politely repeating word for word the statement above.

Reporting and Contacts

Rovers report to the **Public Safety Group Supervisor**.

Name: _____

Phone Number: _____

Reception Centre:

Location: _____

Phone Number: _____

Wind Direction: _____

Evacuation Notice - Example

Form
B5

DATE: _____
TIME: _____

EVACUATION NOTICE

[Insert Company Name] has an emergency at its nearby location.

As a safety precaution, please leave the area in a (north / east / south / west) direction and proceed to the Reception Centre located at _____.

[Insert Company Name] representatives will be available at the Reception Centre to address your questions or concerns.

For assistance, call *[Insert Company Name]* at _____.

Thank you

Tips

- Remember to:
- Remain calm
 - Be courteous
 - Document all actions and comments
 - Notify the **Public Safety Group Supervisor**

Remember to use a handheld H₂S and / or LEL monitor to continually test the atmosphere. Report all H₂S and / or LEL reading changes / increases to the **Public Safety Group Supervisor**.

Response personnel cannot force an evacuation or restrict access to the area unless proper authority has been granted. The authority for forced evacuation is gained only through the declaration of a State of Local Emergency by the local authority.

Before Departure

1.

- Protect yourself
- Ensure you are equipped with all necessary equipment:
 - SCBA
 - Gas monitors
 - Mobile communications or other form of communication
 - Forms
 - Vehicle (4x4) with full tank of fuel
 - Map
- Confirm that your handheld monitor for H₂S and / or LEL is functioning properly.
- Confirm that you have enough copies of the Evacuation Notice.
- Confirm your assignments with the **Public Safety Group Supervisor** and make sure you have a safe route to the assigned location that does not cross the hazardous area.

Notifying Residents / Transients

2.

The **Public Safety Group Supervisor** may request you to patrol the Emergency Planning and Response Zones in search of transients (people passing through the area) and / or residents that couldn't be reached by phone. Make contact with residents / transients and after providing an explanation record their names, contact information, purpose for being in the area (travelling through, live in the area, etc.), current condition, timing of your arrival, and whether or not they require evacuation assistance.

“Hi, I am *[Insert Name]* representing *[Insert Company Name]*. The company is presently experiencing control problems at a nearby location. The situation is serious enough that we are evacuating the public in the area. For your own safety I must ask you to leave the area immediately and check in with a company representative at the Reception Centre. Representatives at the Reception Centre will address any questions you may have and will make arrangements for your temporary accommodations.”

- Ask if they will require evacuation assistance and arrange additional transportation assistance if necessary.
- Make sure they are all accounted for.
- Ensure they gather any supplies they will need for the next 24 hours (medicines, baby food, diapers, etc.).
- If they are able to transport themselves to the Reception Centre provide them with directions that will keep them away from the hazard.
- Ask them if they have any questions.
- Provide them with your name and contact information in case they need assistance later.
- Report to the **Public Safety Group Supervisor**.

Requested Evacuation Assistance

3.

The **Public Safety Group Supervisor** may request you to provide evacuation assistance for residents that have requested it. Ensure you obtain the number of residents requiring assistance, resident's names, location (legal and address), and the reason evacuation assistance is required (medical issue, children home alone, etc). A **Telephoner** should have already contacted and explained the situation to the residents; however, it is a good idea to confirm with the **Public Safety Group Supervisor** that they know you are coming to assist them. If they have not already been informed, contact the resident to tell them you are on your way and provide an estimated time of arrival.

“Hi, I am *[Insert Name]* representing *[Insert Company Name]*. I am here to help you evacuate out of the hazard area and make sure you arrive safely at the Reception Centre. A company representative at the Reception Centre will address any questions you may have and will make arrangements for your temporary accommodations.”

- Try not to scare them. They are aware you might be coming but don't know what to expect.
- Make sure they are all accounted for.
- Ensure they gather any supplies they will need for the next 24 hours (medicines, baby food, diapers, etc.).
- Ask them if they have any questions.
- Once you are satisfied that all personnel from the residence are accounted for, deliver them to the Reception Centre.
- On the way to the Reception Centre, notify the **Public Safety Group Supervisor** of your progress and estimated time of arrival at the Reception Centre.
- Ensure that the residents check in at the Reception Centre with the **Reception Centre Representative** before you leave for your next assignment.

Record Information

4.

Record information on the following forms located within this section:

- Resident Contact Log
- Air Monitoring Log
- ICS 214 Activity Log
- Evacuation Notice

Form ICS 214 Form A5 Form B3 Form B5

Overview

In the event of an emergency in which residents and area users need to be sheltered and / or evacuated, a team of **Telephoners** will be established to contact people in the area and provide instructions to ensure their safety. The **Public Safety Group Supervisor** must be continuously updated with the **Telephoners** progress so that unsuccessful contact attempts and requests for evacuation assistance can be followed up on immediately.

Telephone Personnel Roles

- Confirm resident contact lists are available.
- Confirm communication links.
- In conjunction with the **Public Safety Group Supervisor**, determine who needs to be notified (residents, businesses, area users, etc.). Form B6
- Review with the **Public Safety Group Supervisor** the telephoner scripts to be used: Early Notification / Voluntary Evacuation Message, Shelter-in-Place Phone Message, Evacuation Phone Message. Form B7
- Contact special needs residents at a Level 1 Emergency and provide them with the option to evacuate. Form B8
- Contact the other residents and area users in the EPZ and advise them to evacuate or shelter.
- Contact the schools / school buses to make arrangements for school age children (if applicable).
 - Advise that buses in the affected area leave immediately and that buses should not enter the area.
 - Request a school administrator for the reception centre to assist in managing the children and releasing them to their guardians.
- Document all resident interactions using the Resident Contact Log and report this information to the **Public Safety Group Supervisor**. Immediately advise the **Public Safety Group Supervisor** about unsuccessful contacts and any residents requiring assistance. Form B3
- Document all activities using the ICS 214 Individual Activity Log. Form ICS 214
- Assist with post-incident activities.

Shelter-In-Place Instructions

- Immediately gather everyone indoors and stay there. Do not leave even if you see people outside.
- Close and lock all outside doors and windows. Tape gaps around doors and windows. Leave all inside doors open.
- Turn off appliances or equipment that blows out indoor air or sucks in outside air.
- Turn down furnace thermostats to the minimum setting and turn off air conditioners.
- Extinguish all potential sources of ignition (do not smoke or attempt to start your vehicle).
- Stay off of the phone so that you can be contacted by emergency personnel.
- Stay tuned to local radio and television for possible updates.

Note: For the full Shelter-In-Place instructions see page 2 of the Shelter-In-Place Telephoner Text form located in SECTION 6.0: FORMS.

Who to Contact

- Residents
- Schools / School Bus Transportation
- Businesses
- Public Facilities
- Recreation Areas
- Urban Centres (contact local authority to coordinate)
- Area Users (other oil and gas operators, rail, logging, etc.)
- Trappers
- Guides / Outfitters
- Grazing Lease / Allotment Holders

Priority is given to:

- Those closest to the hazard
- Those downwind of the hazard
- Those with sensitivity issues (health issues, require assistance, etc.)

Tips

- Ensure you have enough personnel to quickly and efficiently shelter / evacuate the required residents / area users.
- A general guideline is to have one **Telephoner** for every seven residences that need to be contacted and one **Telephoners Leader** for every ten **Telephoners**.
- Special needs residents should be contacted at a Level 1 Emergency and given the option to evacuate.

Response personnel cannot force an evacuation or restrict access to the area unless proper authority has been granted. The authority for forced evacuation is gained only through the declaration of a Local State of Emergency by the local authority.

2a. Shelter-In-Place Phone Message

Hello, this is _____ (your name) of _____ (company name).
Is this the _____ (name) residence at _____ (telephone number) ?
_____ (company name) is responding to a (potential) emergency at _____ (location) in your area.

For your safety, it is extremely important that you, and those with you, stay indoors until the potential hazard no longer exists, or you are advised to evacuate.

To help us understand your immediate needs, we need to know:

How many people are at your location now?

Adults _____
Children _____

Is there anyone in your household that you cannot contact to inform them of the situation and advise them to get in doors or stay out of the area?

Yes No

IF YES Whom? _____

Location of the person(s) _____

We will send someone to find them as soon as possible.

Do you have children in school at this time?

Yes No

IF YES What school? _____

Children's names _____

We will contact the school to ensure the safety of your children. Buses will be directed to leave the area immediately. If school is in session, your children will be redirected to the reception centre by their regular bus driver when the school day is over.

Do you have the "Shelter-in-Place" instructions previously provided to you by _____ (company name) ?

Yes No

IF YES Please follow the Shelter-in-Place instructions located inside the resident pamphlet.

IF NO Verbally walk the resident through the Shelter-in-Place instructions on the next page.

Do you understand what I have told you?

Is there an alternate number we can contact you at? _____

If you have any urgent questions, please contact _____ (company name) at _____ (telephone number).

Thank you for your cooperation.

(Pass on all information regarding this call to the Public Safety Group Supervisor immediately)

Note: Refer to Shelter-in-Place instructions on page 2 of the Shelter-in-Place Phone Message located in this section.

Telephoner Communication Flow

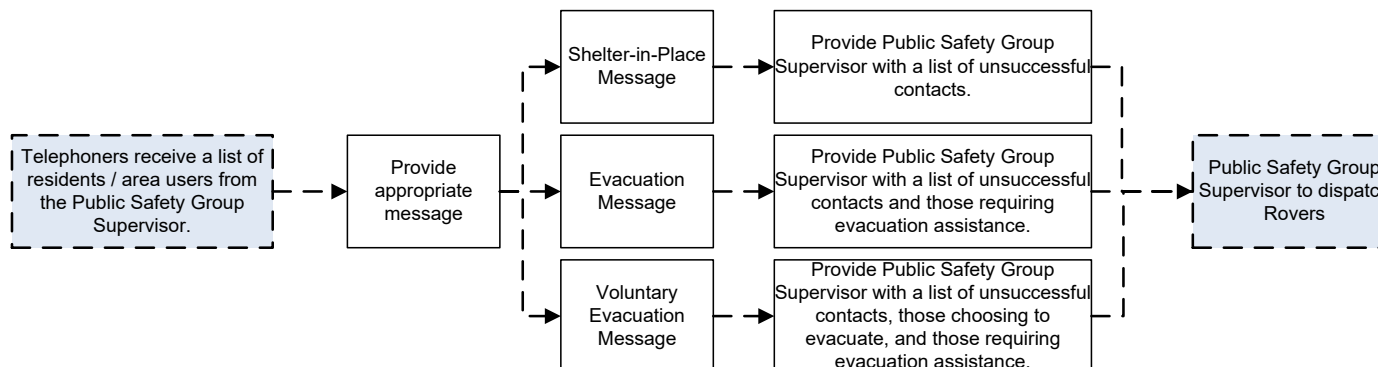

2b. Evacuation Phone Message

Hello, this is _____ (your name) of _____ (company name).
Is this the _____ (name) residence at _____ (telephone number) ?
_____ (company name) is responding to a (potential) emergency at _____ (location) in your area.

For your safety, it is extremely important that you and your family leave your residence immediately and travel in a north / east / south / west direction to our reception centre located at:

To help us understand your immediate needs, we need to know:

How many people are at your location now?

Adults _____
Children _____

Is there anyone in your household that you cannot contact to inform them of the situation and advise them to evacuate away from the area?

Yes No

IF YES Whom? _____

Location of the person(s) _____

We will send someone to find them as soon as possible.

Do you have children in school at this time?

Yes No

IF YES What school? _____

Children's names _____

We will contact the school to ensure the safety of your children. Buses will be directed to leave the area immediately. If school is in session, your children will be redirected to the reception centre by their regular bus driver when the school day is over.

Do you require evacuation / transportation assistance?

Yes No

IF YES We are sending someone to assist you. Please stay indoors and close all doors and windows until a Rover or the local police arrive to evacuate you.

IF NO Provide the resident with:

- Directions to safely travel to the reception centre
- A list of items to bring with them to the reception centre (medications, cell phone, etc.)
- An idea of how long they may be expected to stay at the reception centre
- The option to bring their house pets to the reception centre

Please contact _____ (company name) if you are unable to make it to the reception centre for any reason. Please keep your phone line free so that we can contact you if necessary.

Is there an alternate number we can contact you at? _____

A company representative at the reception centre will address any questions you may have and will make arrangements for your temporary accommodations. Do you understand everything I have told you? Are you leaving immediately?

If you have any urgent questions, please contact _____ (company name) at _____ (telephone number).

Thank you for your cooperation.

(Pass on all information regarding this call to the Public Safety Group Supervisor immediately)

3. Record Information

Record information on the following forms located within this section:

- Resident Contact Log
- ICS 214 Individual Activity Log
- Voluntary Evac Message
- Shelter-in-Place Message
- Evacuation Message

Form ICS 214 Form B3 Form B6 Form B7 Form B8

Reporting and Contacts

Telephoners report to the Public Safety Group Supervisor.

Name: _____

Phone Number: _____

Reception Centre
Location: _____

Phone Number: _____

Wind Direction: _____



Initial Response:

All incidents begin with the initial response (reactive phase) during the first operational period. At the onset of an emergency response an Initial Emergency Report (A1) Form is completed to determine the severity of the emergency and extent of the response. 95% of emergency responses begin and end in the first operational period.

After response personnel ensure their own personal safety by following the First On-Scene Actions, the Five Step Initial Response Guide, and associated tools, provide a structure for the Incident Commander to formulate a response and outlines the steps (key considerations) that need to be addressed and re-addressed when evaluating the incident and associated emergency response.

Ongoing Response:

An ongoing response (proactive phase) is required for an extended emergency response that spans over multiple operational periods and revolves around establishing the objectives, strategies, and tactics for the next upcoming operational period. 5% of incidents require an ongoing response, but once engaged emergency responders will circulate through this cycle multiple times.

After the initial response has been completed, the Five Step Ongoing Response Guide and associated tools provide a cycle to plan the next steps of the emergency response. This continual cycle provides a structure for the Command Staff and General Staff to complete the Incident Action Plan (IAP) and associated documents. The ongoing response cycle and an associated IAP must be completed for each operational period until the incident is stood down.

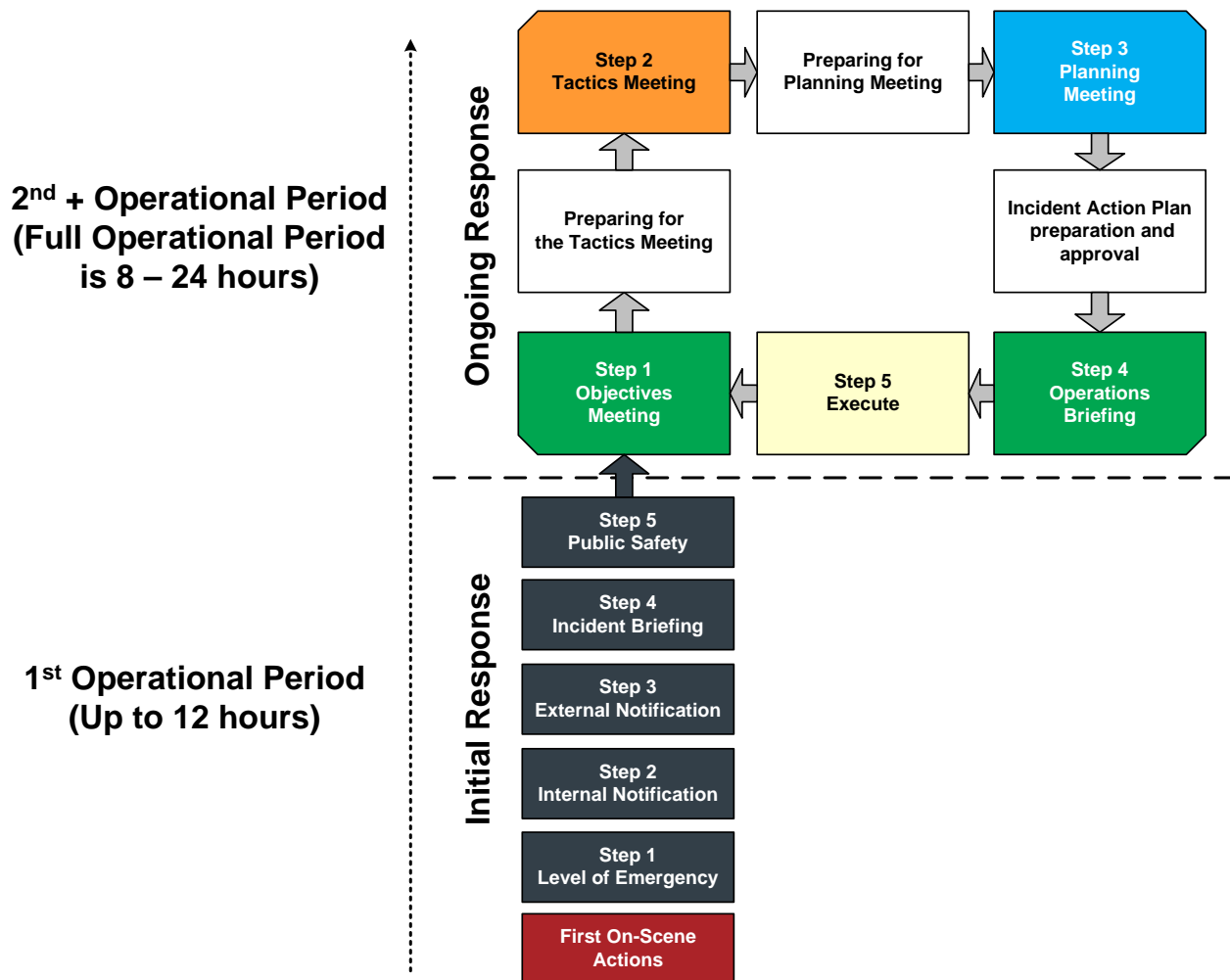

Step 1 - Objectives Meeting

- Incident Commander conducts the meeting.
- Review the ICS 201 form completed during the Initial Response phase and begin the ICS 209 form by evaluating the current incident status.
- Identify issues/problems to resolve using the PPOST methodology.
- Develop SMART (Specific, Measurable, Attainable, Realistic, & Time-Sensitive) objectives to mitigate the identified problems.
- Prioritize the objectives using the ICS 202 form.
- Complete the ICS 202 form and identify initial staffing on the ICS 207 form.
- Utilize IAP Checklist (A4) to complete the IAP.

Prepare for Tactics Meeting

- Develop draft strategies and tactics for each defined objective.
- Outline work assignments and develop an operations organization chart using the ICS 207 form.
- Identify future tactical plans to optimize the Tactics Meeting.
- Begin to prepare a safety analysis once all hazards have been identified using ICS 215A form.

Step 2 - Tactics Meeting

- Operations Section Chief conducts the meeting.
- Review the incident status using the ICS 209 form that was completed during the Objectives Meeting.
- Operations Section Chief proposes strategies and tactics.
- Evaluate and assign resources and personnel.
- Ensure that all strategies have associated tactics to ensure responder safety and complete the ICS 215A form.
- Complete the ICS 215 form and update the ICS 207 form started during the Objectives Meeting.

Prepare for Planning Meeting

- Review and update the ICS 209 form.
- Confirm availability of resources and locations.
- Prepare all information for review at the Planning Meeting.
- Gather any additional incident documentation (i.e., maps and status boards).

Step 3 - Planning Meeting

- Planning Section Chief conducts the meeting.
- Review the incident status using the updated ICS 209 form.
- Confirm the strategies and tactics assigned to achieve the defined objectives.
- Ensure that all assigned tactics can be performed safely and follow the defined safety analysis using the ICS 215A form.
- Incident Commander to give tentative approval of proposed plan and review with key response personnel.

Incident Action Plan Preparation and Approval

- Produce a coordinated and sustainable Incident Action Plan using the IAP Checklist (A4), ICS forms 202, 207, 209, 215, 215A, and gather any additional incident documentation (i.e., maps and status boards).
- Receive final approval from the Incident Commander.
- Define work assignments and break the work into manageable units.
- If necessary, other documents may be included such as a Demobilization plan.

Step 4 - Operations Briefing

- Incident Commander conducts the meeting.
- Provide personnel with work assignments from the IAP.
- Operations Section Chief to brief the organization and provide clarification on all tactical assignments.
- Ensure that all responders know and understand the safety analysis, hazards, and controls.

Step 5 - Execute

- Perform work assignments according to assigned roles.
- Document all actions, decisions, and conversations.
- Constantly evaluate how well the plan is designed and being conducted.
- Adjust the plan and associated actions accordingly.
- Identify additional objectives for the upcoming operational period.
- Schedule next Objectives Meeting if applicable.

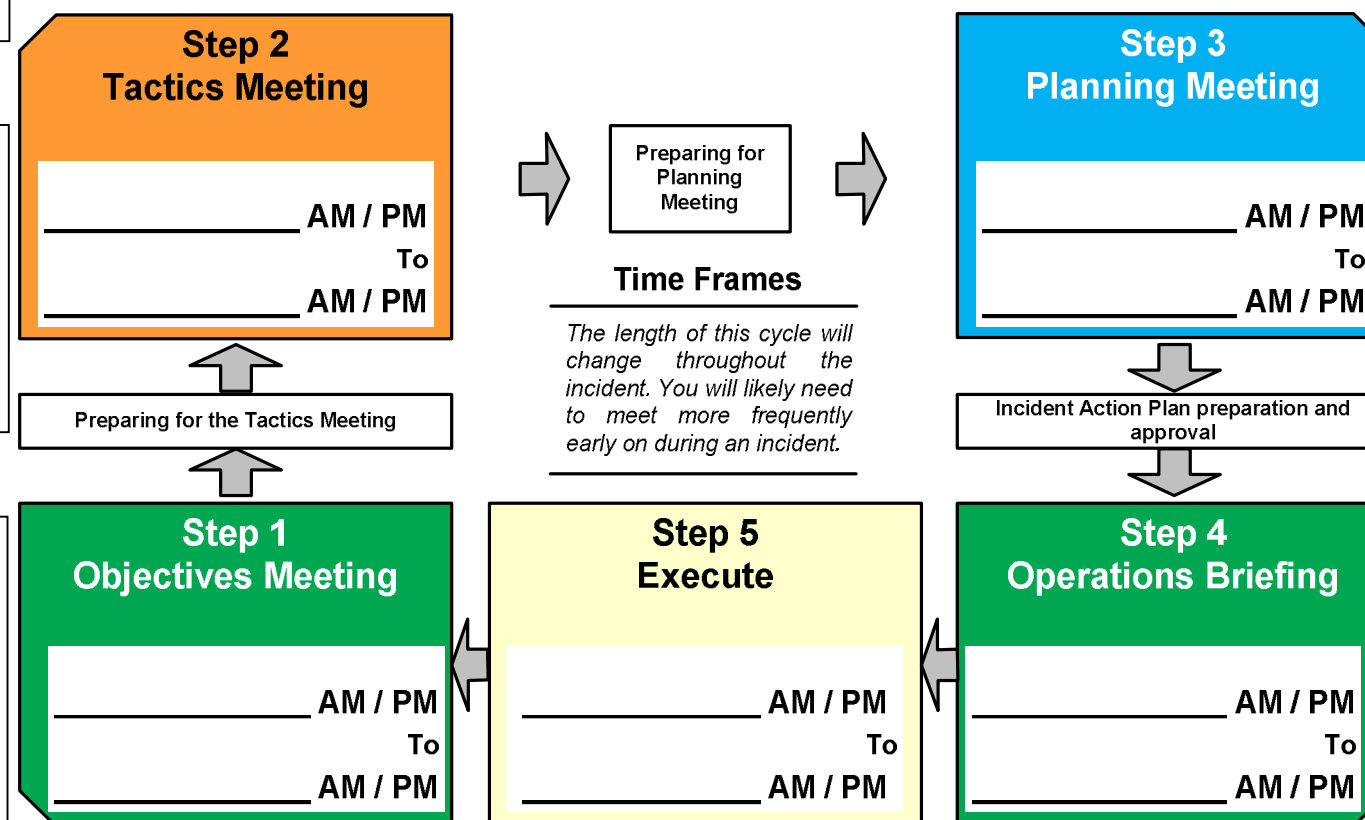
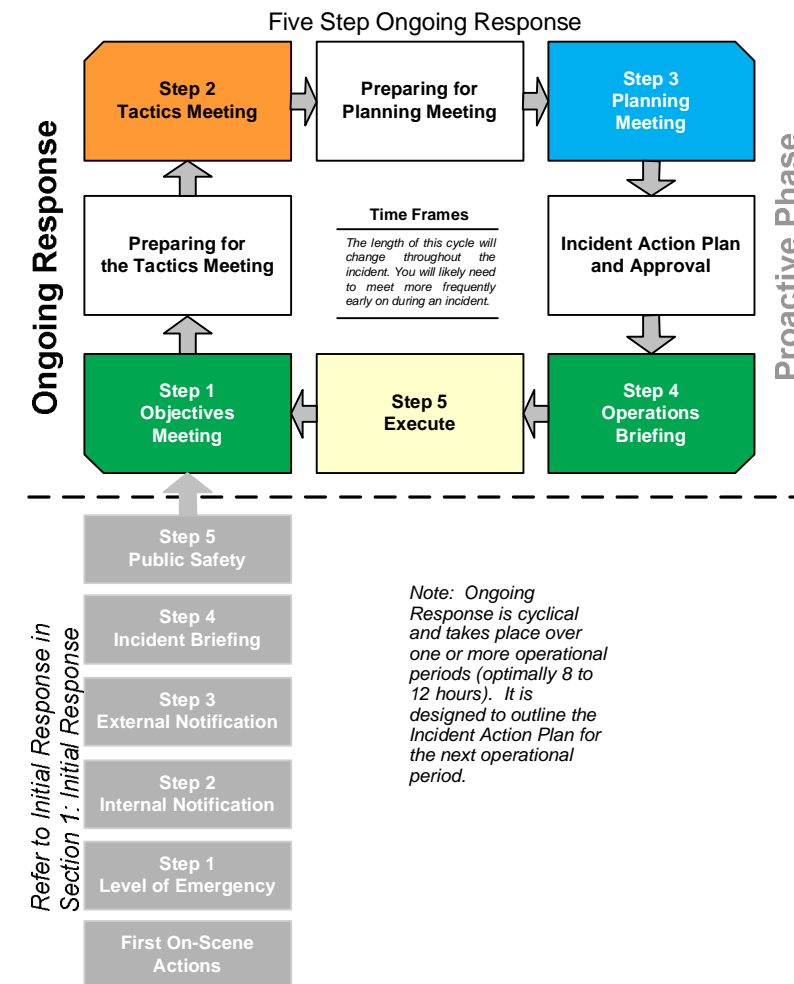

Five Step Ongoing Response Guide



Objectives Meeting



Owner: Incident Commander	Date:	Time:
Roles below will attend only if designated and available		
Attendees:		
<input type="checkbox"/> <i>Incident Commander:</i>	<input type="checkbox"/> <i>Planning Section Chief:</i>	
<input type="checkbox"/> <i>Deputy Incident Commander:</i>	<input type="checkbox"/> <i>Logistics Section Chief:</i>	
<input type="checkbox"/> <i>Operations Section Chief:</i>	<input type="checkbox"/> <i>Finance/Admin. Section Chief:</i>	
<input type="checkbox"/> <i>Planning Section Chief:</i>	<input type="checkbox"/> <i>Safety Officer:</i>	
<input type="checkbox"/> <i>Liaison Officer:</i>	<input type="checkbox"/> <i>Other:</i>	
<input type="checkbox"/> <i>Information Officer:</i>	<input type="checkbox"/> <i>Other:</i>	
Summary:		
<p>The objectives of this meeting are to:</p> <ul style="list-style-type: none"> • Have a completed ICS 202 form agreed upon by all attendees (Command and General Staff). • Establish objectives and priorities for the upcoming operational period. • Begin an ICS 209 Incident Status Summary report. • Begin identifying all required roles on the ICS 207 form. • Begin addressing the Incident Action Plan Checklist (A4). • Schedule and prepare for the Tactics Meeting. 		
Resources:	ICS 202, 207, 209 forms, and the IAP Checklist (A4)	
Agenda Items:		
<input type="checkbox"/> Status Update and review the ICS 201 Incident Briefing form.		
<input type="checkbox"/> Determine incident priorities. Reference the PPOST methodology.		
<input type="checkbox"/> Establish an incident organization that is capable of meeting initial and long-term challenges required to mitigate the incident.		
<input type="checkbox"/> Determine the incident response objectives and complete and ICS 202 Incident Objectives form. They must be SMART (Specific, Measurable, Attainable, Realistic, & Time Sensitive).		
<input type="checkbox"/> Identify initial staffing requirements and begin filling out the ICS 207 Incident Organizational Chart.		
<input type="checkbox"/> Identify and select incident support facilities.		
<input type="checkbox"/> Review the incident objectives for the next operational period so your management team can begin work on the IAP.		
<input type="checkbox"/> Document the incident status to relay to all responding personnel.		
Key Points:		
<ul style="list-style-type: none"> • Ensure that the meeting is documented / recorded. (Utilize the back side of this page.) • Define the hours of work and operational period. • Utilize Incident Action Plan Checklist (A4). • Identify constraints and limitations. • Clarify any staff roles and responsibilities. • Determine expectations of the team for how all communications are to be made. • Discuss and agree on process issues such as resource ordering, cost accounting, operations security, and sensitive information. • Continue to develop tasks for Command and General Staff. • Agree on division of command workload, such as press and agency briefings. 		



Notes:

Empty space for taking notes during the meeting.

Tactics Meeting



Owner: Operations Section Chief	Date:	Time:
Roles below will attend only if designated and available		
Attendees:		
<input type="checkbox"/> <i>Incident Commander:</i>	<input type="checkbox"/> <i>Planning Section Chief:</i>	
<input type="checkbox"/> <i>Deputy Incident Commander:</i>	<input type="checkbox"/> <i>Logistics Section Chief:</i>	
<input type="checkbox"/> <i>Operations Section Chief:</i>	<input type="checkbox"/> <i>Finance/Admin. Section Chief:</i>	
<input type="checkbox"/> <i>Planning Section Chief:</i>	<input type="checkbox"/> <i>Safety Officer:</i>	
<input type="checkbox"/> <i>Liaison Officer:</i>	<input type="checkbox"/> <i>Other:</i>	
<input type="checkbox"/> <i>Information Officer:</i>	<input type="checkbox"/> <i>Other:</i>	
Summary:		
<p>The objectives of this meeting are to:</p> <ul style="list-style-type: none"> • Define tactics, work assignments, and resources to meet actions identified during the Objectives Meeting. • Have completed ICS 215 and 215A forms agreed upon by all attendees (Command and General Staff). • Update the ICS 207 Incident Organization Chart. • Refer to Incident Action Plan Checklist (A4) and continue to add to items accomplished. • Schedule and prepare for the Planning Meeting. 		
Resources:	ICS 209, 215, 215A, and IAP Checklist (A4)	
Agenda Items:		
<input type="checkbox"/> Review ICS 209 Incident Status Summary.		
<input type="checkbox"/> Review incident objectives.		
<input type="checkbox"/> Define tactics to complete objectives set out during the Objectives Meeting.		
<input type="checkbox"/> Provide an operational update and identify tactics to deal with incident.		
<input type="checkbox"/> Identify roles and responsibilities that have to be performed to implement tactics.		
<input type="checkbox"/> Build on already established ICS 207 Incident Organization Chart, check span-of-control, and match up with ICS 215 assignments.		
<p>Complete the Operational Planning Worksheet, ICS 215 (Utilize one form for every established objective).</p> <ul style="list-style-type: none"> <input type="checkbox"/> Identify work assignments <input type="checkbox"/> Identify resources requirements to achieve each work assignment <input type="checkbox"/> Identify overhead staffing needs to support each work assignment <input type="checkbox"/> Identify specialized equipment and supply needs for each work assignment <input type="checkbox"/> Specify reporting times and location for personnel 		
<p>Complete the Incident Action Plan Safety Analysis, ICS 215A.</p> <ul style="list-style-type: none"> <input type="checkbox"/> Identify potential hazard types <input type="checkbox"/> Identify mitigations for associated hazard types 		
<input type="checkbox"/> Identify support facilities and locations.		
Key Points:		
<ul style="list-style-type: none"> • Ensure that the meeting is documented / recorded. (Utilize the back side of this page.) • Review planned actions against incident objectives and priorities. • Utilize a map or chart to depict the operational areas, support facilities, and any key information. • Discuss any applicable open action items. • Consider contingencies and secondary options. 		



Notes:

Planning Meeting



Owner: Planning Section Chief	Date:	Time:
Roles below will attend only if designated and available		
Attendees:		
<input type="checkbox"/> <i>Incident Commander:</i>	<input type="checkbox"/> <i>Planning Section Chief:</i>	
<input type="checkbox"/> <i>Deputy Incident Commander:</i>	<input type="checkbox"/> <i>Logistics Section Chief:</i>	
<input type="checkbox"/> <i>Operations Section Chief:</i>	<input type="checkbox"/> <i>Finance/Admin. Section Chief:</i>	
<input type="checkbox"/> <i>Planning Section Chief:</i>	<input type="checkbox"/> <i>Safety Officer:</i>	
<input type="checkbox"/> <i>Liaison Officer:</i>	<input type="checkbox"/> <i>Other:</i>	
<input type="checkbox"/> <i>Information Officer:</i>	<input type="checkbox"/> <i>Other:</i>	
Summary:		
The objectives of this meeting are to:		
<ul style="list-style-type: none"> • Finalize an Incident Action Plan with the necessary forms based on the objectives, tactics, and strategies outlined from the previous command meetings. • Schedule and prepare for the Operations Briefing. 		
Resources:	IAP Checklist (A4) and all associated ICS forms	
Agenda Items:		
<input type="checkbox"/> Review Incident Action Plan forms (ICS 202, 207, 209, 215, and 215A).		
<input type="checkbox"/> Review Command's incident objectives, priorities, decisions, and direction.		
<input type="checkbox"/> Provide briefing on current situation, resources at risk, weather forecast, and incident projections.		
<input type="checkbox"/> Operations Section Chief provides briefing on:		
<ul style="list-style-type: none"> <input type="checkbox"/> Current operations. <input type="checkbox"/> An overview on the proposed plan including strategy, tactics or work assignments, resource commitment, contingencies, organization structure, and needed support facilities. 		
<input type="checkbox"/> Review the proposed plan to ensure that Command direction, priorities, and operational objectives are met.		
<input type="checkbox"/> Delegate assignments and deadlines to appropriate staff members to assure timely and effective IAP development.		
Key Points:		
<ul style="list-style-type: none"> • Ensure that the meeting is documented / recorded. (Utilize the back side of this page.) • Review IAP Checklist (A4) to ensure that all critical materials have been accounted for in the IAP. • Planning Section Chief brings meeting to order, cover ground rules, and review agenda. • Planning Section Chief requests tacit Command approval of the plan as presented. • Planning Section Chief reviews and validates responsibility for any open actions and management objectives. • Planning Section Chief conducts round table of Command and General Staff to solicit their final input and commitment to the proposed plan. 		



Notes:

Operations Briefing



Owner: Incident Commander	Date:	Time:
Roles below will attend only if designated and available		
Attendees:		
<input type="checkbox"/> <i>Incident Commander:</i>	<input type="checkbox"/> <i>On-Site Group Supervisor</i>	
<input type="checkbox"/> <i>Deputy Incident Commander:</i>	<input type="checkbox"/> <i>Public Safety Group Supervisor</i>	
<input type="checkbox"/> <i>Operations Section Chief:</i>	<input type="checkbox"/> <i>Air Monitor Team Lead</i>	
<input type="checkbox"/> <i>Planning Section Chief:</i>	<input type="checkbox"/> <i>Roadblock Team Lead</i>	
<input type="checkbox"/> <i>Liaison Officer:</i>	<input type="checkbox"/> <i>Rover Team Lead</i>	
<input type="checkbox"/> <i>Information Officer:</i>	<input type="checkbox"/> <i>Telephoner Team Lead</i>	
<input type="checkbox"/> <i>Planning Section Chief:</i>	<input type="checkbox"/> <i>Reception Centre Representatives</i>	
<input type="checkbox"/> <i>Logistics Section Chief:</i>	<input type="checkbox"/> <i>Other:</i>	
<input type="checkbox"/> <i>Finance/Admin. Section Chief:</i>	<input type="checkbox"/> <i>Other:</i>	
<input type="checkbox"/> <i>Safety Officer:</i>	<input type="checkbox"/> <i>Other:</i>	
<input type="checkbox"/> <i>Staging Area Manager:</i>	<input type="checkbox"/> <i>Other:</i>	
Summary:		
<p>The objectives of this meeting are to:</p> <ul style="list-style-type: none"> • Review a summary of the incident status with all responders. • Relay objectives, tactics, and strategies. • Reinforce/relay the safety message. • Assign roles & responsibilities and tasks for all responders to accomplish. • Execute the response. • Tentatively schedule next Objectives Meeting and identify potential problems/issues to address in the next operational period. 		
Resources:	IAP Checklist (A4) and all associated ICS forms	
Agenda Items:		
<input type="checkbox"/> Planning Section Chief briefly walks through the IAP components and makes changes as needed.		
<input type="checkbox"/> Operations Section Chief conducts roll call of the Operation Section Supervisors and provides a briefing on emergency response.		
<input type="checkbox"/> Operations Section Chief briefs supervisory personnel on their assignments along with clarification on any of their issues and concerns.		
<input type="checkbox"/> Safety Officer covers major safety issues.		
<input type="checkbox"/> Logistics Section Chief covers logistical support of operations (communications, supply, transportation, medical, etc).		
<input type="checkbox"/> Finance / Admin. Section Chief covers time & cost tracking, procurement, and compensation process.		
<input type="checkbox"/> General Staff to cover issues applicable to Operations Section personnel.		
Key Points:		
<ul style="list-style-type: none"> • Ensure that the meeting is documented / recorded. (Utilize the back side of this page.) • Planning Section Chief opens briefing, covers ground rules, agenda, and conducts roll call of Command and General Staff members. • Establish a briefing and message for all responders. • Review pre-determined public and media statements. • Planning Section Chief solicits final comments and adjourns briefing. 		



Notes:

Large empty rectangular area for taking notes.



Steel Reef Infrastructure Corp. SE Saskatchewan Pipelines
Suite 1600, 333 - 7 Avenue SW Calgary, AB
Bus: 403-263-8333
24 Emergency: 866-441-6203

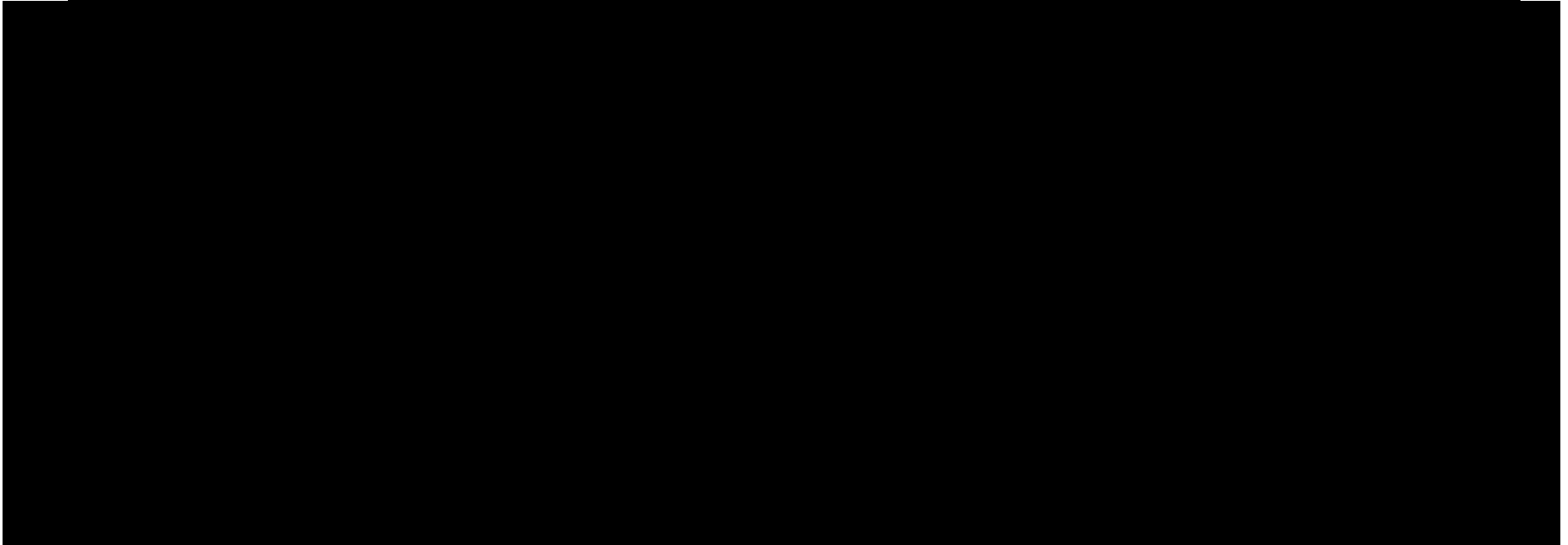



Section 3: Communications & Media

- Media Relations and Generic Media Statement..... 1**
 - Generic Media Statement..... 1
 - Media Management 1
 - On-Site Media Spokesperson..... 2
 - Managing the Media On-Site..... 2
- Internal Communication..... 3**
- Communicating with the Public..... 3**
 - Information Disseminated to the Public..... 3
 - Preparing a Preliminary Media Statement..... 4



Media Relations and Generic Media Statement

Any incident that affects the environment, the health and safety of individuals, or causes extensive property damage could be a news "item". When such an incident occurs, the media should not be avoided. The key is to establish good rapport with the media early in the life of the emergency. Open and honest communication will help to create favourable public opinion and could help to prevent the public from overreacting to the incident.

Media releases are generated and released as significant developments occur. The company is expected to coordinate media releases with the relevant government agencies prior to release to provide consistency and accuracy of information. Information is communicated through written news releases, news conferences, and any other effective means that the company chooses to use. The company must identify a spokesperson to carry out this role and to interact with applicable government agencies.

Media releases will be developed by the Emergency Support Team in conjunction with the applicable regulatory agency. The Emergency Support Team will assign a Corporate Media Spokesperson to deliver the approved messages.

Media at the field level will be coordinated by the Information Officer with the Support of Communications / Media from the Emergency Support Team. If media have arrived at the emergency site and the designated Information Officer is not yet available, only the Incident Commander or their designate can act as the company spokesperson, and will issue only the information below.

Future statements will be prepared by the Emergency Support Team and should be issued only by the designated Corporate Media Spokesperson. All media statements will be reviewed with the regulatory agency's Media Coordinator.

All information that is given to the media should be recorded. See **Section 6: Forms** for the C2 Media Contact Log.

Generic Media Statement

"We are currently dealing with the situation at hand to ensure the safety of the public, our personnel, and the environment. A statement will be released by the company once the facts have been determined. If you would like to leave your business card or phone number, a company representative will provide you with more information as it becomes available."

Media Management

- Do not wait until you are contacted by the media to react to their inquiries. By preparing in advance, the company will appear to be organized, aware, and actively responding to the situation. The essence of effective media management is preparation in advance of any media contact.
- It is important when contacting the media with a news release that you do not favour one media organization or agency over another. To minimize the chances of creating a prejudicial situation, deal solely with major umbrella press agencies.
- If media representatives are not provided with the basic information, it can be assumed that they will fill the gap with material from less reliable sources.

Be aware at all times that it is possible for the media or others to be monitoring your radio, cellular phone, or telephone conversations.



On-Site Media Spokesperson

Depending on the specific emergency an on-site spokesperson may be required to handle all on-camera activities requested by the media. Only approved and trained spokespeople will be allowed to provide comment to the media. The Emergency Support Team will identify any and all media spokespersons. The Information Officer or Incident Commander may serve as the on-site Media Spokesperson or the Emergency Support Team may send the Corporate Media Spokesperson to the site. This representative will endeavor to maintain a favourable public image on behalf of the company. It is important that they keep in mind the following:

- The Dos and Don'ts of conducting yourself on camera; 75% of information comes from non-verbal actions (gestures, tone, posture, etc.)
- Public appearance, ensuring appropriate and approved wardrobe
- Preparation in communicating the media release in advance so the message feels natural
- How to handle impromptu or "off the record" inquiries from the media

Managing the Media On-Site

Depending upon the size and/or scope of the emergency to the incident site, the media will likely travel to site and attempt to secure coverage of the situation. Usually the size and nature of an emergency will determine the amount of media attention garnered. It is important everyone on-site understands how to properly manage the media and that only designated individuals are to speak to the media. It is recommended that only individuals with adequate media training have even casual interactions with the media.

Media Briefing Areas are to be designated by the Incident Commander if advised by the Communication & Media position. The Information Officer will, if required by the Emergency Support Team and Incident Commander, determine the need for media management at the incident site.

As appropriate, the Information Officer should be designated to oversee local news media management. In order to address the needs of the media at the incident site, the following guidelines should be considered:

- If practical, an information centre will be set up nearby the incident site. All on-site media will be informed that this will be the only place where information is to be released.
- During an emergency situation, media access to company property is strictly prohibited unless prior approval has been given by the Emergency Support Team. If the Incident Commander deems the situation safe and access is granted to company property, media personnel must be accompanied at all times and wearing appropriate personal protective equipment (PPE).
- Ensure that if any media personnel are granted access on-site all potential hazards are identified and handled appropriately prior to their arrival (i.e. all on-site personnel are wearing proper PPE, operating equipment safely, etc.).
- With the exception of providing the initial prepared company statement, any requests by the media for information or interviews should be referred to the Information Officer.
- For an emergency that lasts more than 24 hours, consideration will be given to establishing a newsroom for all required personnel.
 - Ensure it is located a safe distance away from the incident.
 - Ensure proper internet and telephone access is made available.
 - Large enough to accommodate all of the potential media personnel.



Internal Communication

Internal communication plans for company personnel must include:

- Identification of primary and secondary communication methods during an incident.
- Procedures to control flow of information*:
 - Ensure facts and relevant information are distributed to key responders
 - Proper management of sensitive information
 - Camera and cellphone photo restrictions
 - Social media protocol

** Note: These procedures are developed by the Information Officer during the incident.*

Communicating with the Public

Communication plans for contacting affected parties must be in place:

- When affected parties are within the Emergency Planning Zone (EPZ) at the beginning of drilling and initial completion operations.
- A minimum of 24 hours before drilling operations enter a sour zone.
- At the conclusion of drilling and initial completion operations.
- At the beginning and conclusion of other operations including workovers, flaring, fracking, etc.

Information Disseminated to the Public

The company must make the following information available to the public, while maintaining documentation, as soon as possible during an incident:

- **To the affected public at the onset of the incident:**
 - Type and status of the incident.
 - Location and proximity of the incident to people in the vicinity.
 - Public protection measures to follow, evacuation instructions, and any other emergency response measures to consider.
 - Actions being taken to respond to the situation, including anticipated time period.
 - Contacts for additional information.
- **To the affected public during the incident:**
 - Description of the products involved and their short-term and long-term effects.
 - Effects the incident may have on people in the vicinity.
 - Areas impacted by the incident.
 - Actions the affected public should take if they experience adverse effects.
 - An explanation of the steps taken to address concerns.
 - An explanation of the steps to be taken to prevent similar emergencies in the future.



Information Disseminated to the Public, continued

- **To the general public during the incident:**
 - Type and status of the incident.
 - Location of the incident.
 - Areas impacted by the incident.
 - Description of the products involved.
 - Contacts for additional information.
 - Actions being taken to respond to the situation, including anticipated time period.
- **To the evacuated or sheltered public post-incident:**
 - Status of recovery.
 - Financial reimbursement information.
 - Contacts for additional information.

Preparing a Preliminary Media Statement

This verbal or written statement is the initial information given only to the media by the Information Officer, Incident Commander (or alternate) when the company's designated Media Spokesperson is unavailable, or authorizes a press release at the local level. See **Section 6: Forms** for the C1 Preliminary Media Statement form.

The preliminary statement shall contain:

- What, when, and where the incident occurred:
 - State the general nature and description of the incident.
 - Associate the incident location to the nearest major centre and the exact time the incident began or was discovered.
 - For example: At 11:00 am, today, September 13th, 2012, a warehouse at our battery location northeast of Wainwright caught on fire.
- Injuries / fatalities / damages:
 - Clearly distinguish the severity of the injuries sustained and if any fatalities occurred.
 - State the number of people currently receiving treatment.
 - Ensure no names are released to the media; it is important to keep this information private until all families and next-of-kin notifications are made.
 - For example: We have confirmed that three employees sustained injuries, two minor and one major. All of the injured casualties have been transported to the nearest care facilities and are receiving treatment.
- The current status of the emergency:
 - Indicate the nature of the situation; i.e. what is being done by whom.
 - For example: Emergency crews currently have the fire under control and local authorities are investigating the cause. We are actively notifying the employee's families of the incident.
- When to expect more information:
 - For example: Our designated spokesperson will be issuing a formal statement once we have more information confirmed. Thank you for your cooperation and we will not be accepting any questions at this time.



Preparing a Preliminary Media Statement, continued

What not to do:

- Don't downplay the seriousness of the event or speculate on volumes, damage or timelines.
- Don't point fingers; liability will be determined later by appropriate authorities.
- Primary focus must remain on the company's commitment to addressing the response and recovery effort.
- Attempt to avoid any questions if possible, as designated media personnel should handle all media questions.
- Avoid saying "no comment." It sounds like you're hiding something. If necessary, explain why it is not appropriate or possible for you to answer the question.



Section 4: Emergency Response Procedures

Public Protection Measures	1
Public Protection Measures Flowchart.....	1
Evacuation	2
Shelter-in-Place.....	3
Establishing and Isolating a Perimeter	4
Ignition	5
H ₂ S / HVP Ignition Procedure	7
Road and Airspace Closures	9
Air Monitoring.....	9
Spill Response, Containment and Recovery	1
Spill Response	1
Spill Response Objectives and Strategies.....	1
Control Points	2
Health and Safety.....	4
Initial Site Assessment	4
Safety Briefing.....	4
Initial Site Safety and Hazard Control Plan	4
Western Canadian Spill Services (WCSS).....	5
Provincial Petroleum Release Reporting Requirements Chart.....	7
Containment and Recovery	9
Understanding Environments – Ground and Water	9
Containment of Spilled Product	11
Containment to Recovery Process for Moving Water	15
Recovery of Spilled Product	16
Recovery Techniques.....	17
Spill Control Tactics (Sorbents, Berms, Trench and Bell Hole, Aquadam, Culvert Block, Boom Deployment, and Skimmers / Temporary Storage / Vacuum Units)	
Post-Incident	1
Call Down Notification	1
Public Care and Assistance.....	1
Clean-up and Repair	2
Third Party Investigations	2
Review and Debriefing	3
Critical Incident Stress Debriefing (CISD)	3
Post-Incident / Accident Investigation	4
Medical Emergencies	1
First Aid Information	2
Next-of-Kin Notification.....	5
Medical Evacuation (MEDEVAC) Procedure.....	7



Responder Safety	1
Site Safety.....	1
On-Site Work Areas.....	2
Working Alone.....	4
Missing Persons	6
Rest Periods.....	6
Fire / Explosion.....	1
Classification of Fires.....	3
Response Actions Based on Type of Fire	4
Transportation Incidents	1
First On-Scene Transportation (Road, Rail, Marine) Incident Flowchart.....	1
Loss, Theft or Unlawful Interference Reporting Flowchart.....	2
Motor Vehicle Accidents	3
Emergency Response Assistance Canada (ERAC) Plan.....	4
CANUTEC – Canadian Transport Emergency Centre	4
Dangerous Goods References.....	5
TDG Reportable Quantities.....	5
Rail Car Identification Chart.....	7
Road Trailer Identification Chart.....	9
Table of Markings, Labels and Placards.....	11
TDG 30 Day Follow-up Report Form.....	13
Weather and Natural Disasters	1
Earthquake.....	2
Floods	4
Thunderstorm and Lightning Safety	6
Tornados	7
Winter Storms: Blizzards, Freezing Rain, Heavy Snow, Blowing Snow	7
After a Disaster.....	9
Security Incidents.....	1
Responding to threats.....	1
Bomb threats.....	2
Suspicious packages	5
Trespassing.....	7
Vandalism	8
Terrorism	8
Cyber-Attacks.....	9
Security Management Program	
Animal Encounters	1
First Responders to Animal attacks.....	1
Bears	2
Cougars	4
Large Hooved Animals (Ungulates).....	6
Rattle Snakes.....	7
Wolves	8
Bees and Wasps	9
EpiPens	10



Public Protection Measures

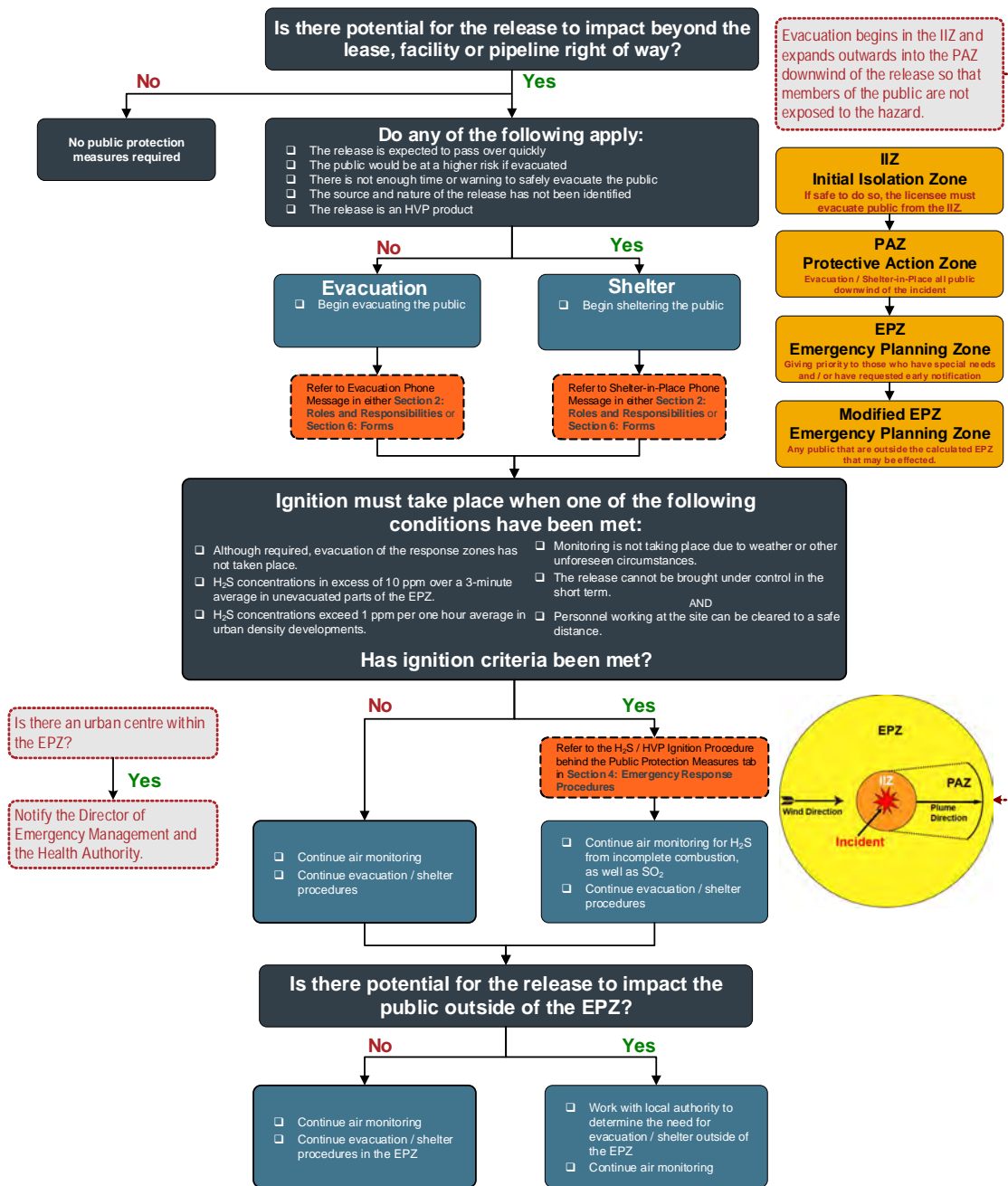

Evacuation Requirements

Revised November 2021

For a sour gas release, the licensee must continuously assess and act on the need to expand the evacuation area based on the monitored levels of H₂S and SO₂. In the absence of monitored readings, responders should advise the residents to Shelter-in-Place.

H ₂ S Requirements		SO ₂ Requirements	
1 to 10 ppm (3 minute average)	Individuals who requested notification so that they can voluntarily evacuate before any exposure to H ₂ S must be notified.	0.3 ppm (24-hour average)	Immediate evacuation of the area must take place.
Above 10 ppm (3 minute average)	Local conditions must be assessed and all persons must be advised to evacuate and/or shelter.	1 ppm (3-hour average)	
* If monitored levels over the 3 minute interval are declining (i.e., three readings show a decline from 15 ppm to 10 ppm to 8 ppm over 3 minutes), evacuation may not be necessary even though the average over the 3 minute interval would be 11 ppm. Licensees should use proper judgement in determining if evacuation is required.		5 ppm (15-minute average)	

Note: This section is based on Alberta Regulations; however, the same standards will be followed by the company for operations in other provinces.



Public Protection Measures, continued

There are three primary public protection measures that are used to ensure the safety of the public in the event of an incident: evacuation, shelter-in-place and ignition.

Evacuation

For long-term releases, evacuation is preferred to sheltering if public safety can be assured during the evacuation process.

Evacuation is a viable public protection measure in circumstances when:

- The location of the plume is known, and safe egress routes can be assured
- The release will not likely be contained in the near future
- Visibility and road conditions are good
- The residents clearly understand their directions

Tactical Evacuation: A measure to immediately move people to a safe area as part of emergency response and operations. Does not require approval from local authority but the local authority may enact an evacuation order, if required. The local authority must be advised if a tactical evacuation has occurred. Appropriate methods must be utilized to ensure transients (hunters, trappers, recreational users, non-resident landowners, etc.) within the EPZ are located and evacuated. Refer to Section 6: Forms for Evacuation Scripts for information that should be communicated as part of the evacuation process.

Planned Evacuation: An evacuation coordinated by local government authority that can authorize evacuation alerts and orders.

Residents should also be evacuated during ongoing emergency flaring or burning if their health and safety could be affected by the operation.

Special procedures may be required for evacuating large industrial operations and/or public facilities. If large numbers of people are involved, the licensee must address assistance with transportation. Refer to the Area Specific Information Section for information regarding transportation (e.g., providing school buses) or other changes in the normal notification procedures.

The licensee must continuously assess and act on the need to expand the evacuation area, based on the specifics of the incident, including harmful levels of hazardous substances.

The licensee is expected to monitor the air quality along the edge of the EPZ to determine if sheltering or evacuation criteria have been met outside the EPZ. Evacuation outside of the EPZ must be coordinated with the Local Authority.

Appropriate methods must be utilized to ensure transients (hunters, trappers, recreational users, non-resident landowners, etc.) within the EPZ are located and evacuated. When a tactical evacuation has taken place, the appropriate local authority must be notified.



Public Protection Measures, continued

Shelter-In-Place

Shelter-in-place is considered the primary safety measure when the hazard is of a limited duration or the public would be at a higher risk if evacuated. Sheltering within a building creates an indoor buffer to protect affected individuals from higher (more toxic) concentrations that may exist outdoors. The goal is to reduce the movement of air into and out of the building until either the hazard has passed, or other appropriate emergency actions can be taken (such as evacuation).

Sheltering indoors is a viable public protection measure in circumstances when:

- There is insufficient time or warning to safely evacuate the public
- Residents are waiting for evacuation assistance
- The release will be of a limited size and /or duration
- The location of the release has not been identified
- The public would be at a higher risk if evacuated
- Escape routes traverse the hazards

Refer to either **Section 2: Roles and Responsibilities** or **Section 6: Forms** for the Shelter-in-Place Phone Message script to be used when contacting residents. Residents advised to shelter-in-place will be notified if additional measures are required, and when it is “all-clear”.

Sheltering Measures for HVP Product Release

For a flammable or combustible liquid fire to start, a mixture of vapour and air must be ignited. There are many possible ignition sources:

- Sparks from electrical tools and equipment
- Sparks, arcs, and hot metal surfaces from welding and cutting
- Tobacco smoking
- Open flames from portable torches and heating units, boilers, pilot lights, ovens, and driers
- Hot surfaces such as boilers, furnaces, steam pipes, electric lamps, hot plates, irons, hot ducts and flues, electric coils, and hot bearings
- Embers and sparks from incinerators, foundry cupolas, fireboxes, and furnaces
- Sparks from grinding and crushing operations
- Sparks caused by static electricity from rotating belts, mixing operations or improper transfer of flammable or hot combustible liquids

You can eliminate many ignition sources by:

- Removing open flames and spark-producing equipment
- Not smoking around these liquids
- Using approved explosion proof equipment in hazardous areas



Public Protection Measures, continued

1. Identify the location of the incident on the map:



2. Determine the size of response zones (hazard areas):

- EPZ - Emergency Planning Zone
- IIZ - Initial Isolation Zone
- PAZ - Protective Action Zone

You can find this information:

- a) Labeled on the map
- b) In the site specific tables
- c) As the yellow area on the map

If the incident is at a facility or if you have not yet confirmed the exact location of the incident, you must use the largest EPZ for the area. The largest EPZ for the area is shown in yellow on the map.

3. Determine the wind direction

Look for wind direction indications such as flags, windsocks, direction of smoke, etc..

Draw the wind direction on the map with an arrow.



4. Draw the zones on map:

- a) EPZ - The entire hazard area
- b) IIZ - Those closest to the hazard
- c) PAZ - Those downwind of the hazard

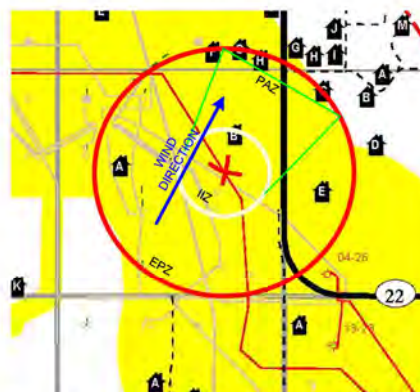

5. Isolate the hazard area with roadblocks

If any residences exist between the optimal roadblock location and the EPZ, expand the EPZ to include those residences.

Additionally, if any residences only route of egress is through the EPZ, expand the EPZ to include those residences.



6. Following the appropriate provincial public protection measures chart, initiate public safety activities.

Residents in the IIZ are closest to the hazard and are the most at risk of being adversely affected.

Residents in the PAZ are the second group to be evacuated / sheltered in place as being downwind of the hazard puts them at a higher risk than the rest of the residences in the EPZ that are upwind or crosswind from the hazard.



Public Protection Measures, continued

Ignition

In conjunction with shelter-in-place and evacuation strategies, the release may be ignited at the source in order to reduce public exposure to the hazard. The combustion of the hydrogen sulphide (H₂S) results in the produced sulphur dioxide (SO₂) being carried high into the atmosphere allowing additional time for the public to safely evacuate. If an immediate threat to human life exists and there is not sufficient time to evacuate the hazard area or the Emergency Planning Zone (EPZ) – whichever is bigger – the On-Site Group Supervisor is authorized to ignite the release.

Note: Only those personnel trained in ignition procedures can determine if ignition is required and operate the ignition equipment.

Ignition of an HVP product release should occur only after the position of the plume has been established, after careful deliberation, and when safe to do so.

Until such time that a decision has been made to ignite a release, the licensee should take steps to minimize any chance of unplanned ignition in the area.

Note: Initial location of the plume may be identified by the following methods:

- *Visually (i.e.; frost or condensation buildup, white cloud or dust cloud, dead vegetation, bubbling water, etc.)*
- *Auditory (i.e.; hissing or whistling sound, etc.)*
- *Smell (i.e.; smell of mercaptan – rotten eggs)*

When making the decision to ignite, the licensee must take the following into consideration:

- If personnel are on-site, proceed to muster location for headcount and further instructions. Refer to Five Step Initial Response Guide in **Section 1: Initial Response** for First On-Scene Actions.
- Refer to the H₂S / HVP Ignition Procedure on the following page for further considerations.

If at all possible, the On-Site Group Supervisor must consult with higher authority individuals within the company (ideally the Operations Section Chief, Incident Commander, etc.) and the appropriate government regulator.



Pre-Ignition Considerations – On-Site Group Supervisor

When making the decision to ignite, the licensee must take the following into consideration:

Hydrogen Sulphide (H₂S)

- Risk of exposure / injury to the public or response workers.
- Proximity to residences, public facilities, towns or urban centres.
- Availability of air monitoring equipment and personnel.
- Availability of ignition equipment, and training of staff in its use.
- Detectable concentration of H₂S and/or flammable gases near the source of the release and within the EPZ.
- Status of evacuation.
- Duration of the release and potential volume.
- Wind/Weather conditions and general topography.
- Impacts to livestock and other values at risk including property, timber or infrastructure.
- Fire hazard after ignition in relation to adjacent forested or cropland area.
- Safety of the Ignition Team (hazard area identification, protective gear).

High Vapour Pressure (HVP)

- Increased risk(s) of delayed ignition.
- If the perimeter of the hazard area has been established.
- If the public has been evacuated from the area.
- If ignition will worsen the situation by endangering the public or the environment or damaging the equipment used to control the product.
- If wind direction has been established and is being continually monitored.
- If the possibility of an explosion has been assessed (i.e., obstructions or regions of congestion within the perimeter of the dispersion vapour cloud).

Ignition must take place when one of the following conditions has been met:

- Although required, evacuation of the response zones has not taken place.
- Monitoring results indicate H₂S concentrations in excess of 10 ppm over a 3-minute average in unevacuated parts of the EPZ.
- H₂S concentrations exceed 1 ppm per one hour average in urban density developments.
- Monitoring is not taking place due to weather or other unforeseen circumstances
- The release cannot be brought under control in the short term (ignition decision will be made by Incident Commander. Notify Regulatory Agency intention to ignite. AND Personnel working at the site can be cleared to a safe distance.

If monitoring levels are declining, then the situation needs to be continuously assessed for ignition. Once any of the above conditions have been met, ignition must occur within 15 minutes of the decision to ignite.

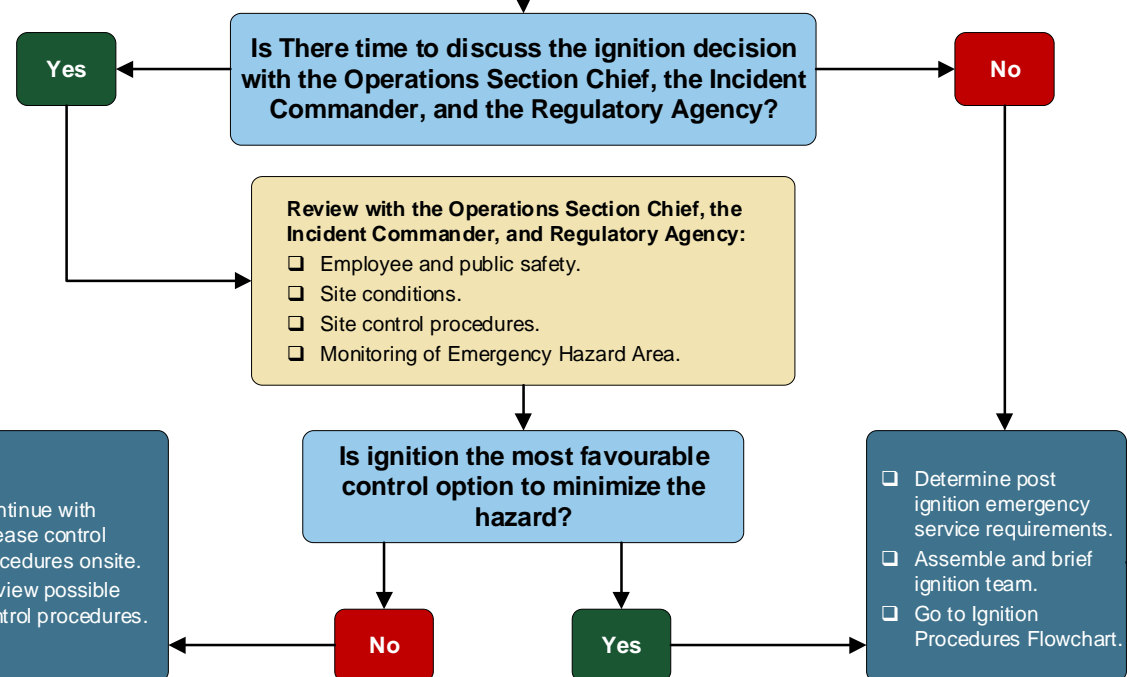

Ignition Procedure – On-Site Group Supervisor

Preplanning

Prior to ignition the Operations Section Chief will:

- Ensure all nonessential personnel are evacuated.
- Isolate the hazard area using manned roadblocks.
- Assemble the Ignition Team (2 people).
- Ensure the Ignition Team is protected with personal protective equipment, clothing and breathing apparatus (cover exposed skin).
- Erect windsock and streamers (if time permits).
- Monitor the area for combustible gas.
- Fully discuss ignition procedures.
- Check radio communications.

Approach

Select a position to attempt safe ignition which will:

- Allow for safe retreat.
- Be upwind of the gas leak (300m minimum from edge of identified vapor plume, approach no closer than 100m on repeated ignition attempts).
- Be in an area where no combustible gas is detected.
- If possible, get behind a hill, building, tree or other protective barrier to shield yourself.

Attempt Ignition

- Fire flare gun to hit vapour cloud at the perimeter where air to fuel mixtures are correct for ignition (near outer edge and ground level).
- Turn away from target.

Example Ignition Kit

- 2 Flare Pistol
- 36 Flares
- 2 Safety harness with front D-ring
- 2 30m (100ft) flame resistant rope
- 2 Flame resistant coveralls
- 2 Sets of ear protection
- 2 Hard hats with face shield
- 2 Flame resistant hard hat liners (balaclava or regular style)
- 1 LEL Gas detector
- 1 H₂S Gas detector
- 4 Self contained breathing apparatus (positive pressure) with 30 minute air supply, includes 2 spare bottles
- 1 Radio equipped vehicle

Plume Ignited?

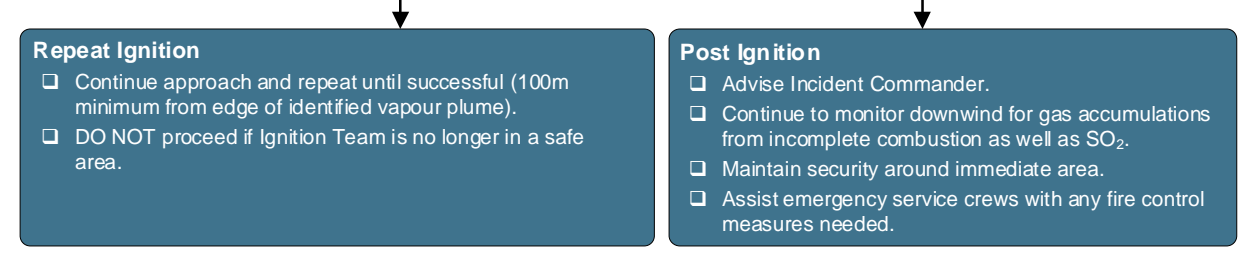

Revised November 2021



Public Protection Measures, continued

Road and Airspace Closures

The company should receive authorization from local authorities or the RCMP before establishing roadblocks on public roads. The company must contact the RCMP and the transportation authority to have one-, two- or three-digit highways closed. However, if the safety of the public is in jeopardy, the company must be prepared to quickly restrict access to the area before contacting these agencies.

If warranted, the regulatory agency can issue a Closure Order that provides legal authority to close the area. The local authority may, if warranted, declare a Local State of Emergency. This grants the local authority special powers to do such things as road closures or declare mandatory evacuation.

The public must also be prevented from flying into the airspace above a gas release. It may be necessary to issue a Notice to Airmen (NOTAM) to advise pilots of restrictions in the airspace above the EPZ or to close the airspace for a certain radius from the release (a no-fly zone). NOTAMs are issued by NAV Canada and airspace closures are issued by Transport Canada's Aviation Operations Centre (AVOPS). NOTAMs or airspace closures may be requested by the licensee at a level 2 or level 3 emergency.

Air Monitoring

Air monitoring equipment is used to:

- Track/follow the plume.
- Determine if ignition criteria are met.
- Determine whether evacuation and / or shelter-in-place criteria have been met.
- Determine roadblock locations.
- Determine concentrations in areas being evacuated to ensure that evacuation is safe.
- Assist in determining when the emergency can be downgraded.

As such, H₂S, SO₂, LEL or other toxic substance concentrations will be monitored continuously during the incident response and it is crucial that Air Monitors continuously update their direct supervisor with monitored results.

- Air monitors (personal handheld, stationary and mobile) should be dispatched at a Level 1 Emergency.
- Air quality monitoring occurs downwind, with priority being directed to the nearest un-evacuated residence or area where people may be present.
- Licensee personnel will monitor and record the concentrations until a mobile air monitoring unit arrives or until the incident is over. At minimum, these readings must include LEL and H₂S.
- Mobile air quality monitoring units must be dispatched when it is evident that spill control measures are not effective and that a sour product release is likely to occur.
- For HVP releases, monitoring may occur downwind or upwind, depending on how the plume is tracking, with priority being directed to the nearest un-evacuated residence or areas where people may be present. The licensee is expected to provide monitored HVP product LEL information on a regular basis for the duration of the incident.
- If a sour gas release has been ignited, the licensee should continue to monitor response zones for H₂S from incomplete combustion, as well as SO₂.
- Ensure all equipment is operational and the appropriate documentation is available to verify testing and calibration requirements.



Spill Response

The spill response section can be used as a quick reference by first-on-scene responders to select and implement containment and recovery tactics with spill response equipment during the first 48-72 hours of the response. This section contains a collection of inland spill tactics that can be applied using obtainable resources to a liquid product release until additional resources and personnel arrive on site. This section is a reference tool and supplement to prior training, field experience, technical instruction, and equipment operation knowledge. The licensee will rely on the training and judgment of its first-on-scene responders to select only those tactics that can be accomplished safely.

Refer to the Petroleum Industry Release Reporting Requirements chart at the end of this section to determine the TDG and Provincial Reporting Requirements for each class of chemicals (as classified by the TDG Hazard Classification System).

Spill Response Objectives and Strategies

Objectives establish the desired outcomes of an incident and are statements of intent related directly to response priorities. Priorities are situational and influenced by many factors, with life safety always being the highest priority followed by incident stabilization and property and environment. The Incident Commander comes to a consensus on a collective set of objectives with response strategies. The following table contains some standard objectives with example strategies that can be utilized to assist in the first four to six hours of a spill response.

Objectives	Strategies
Ensure the safety of citizens and response personnel	Identify hazard(s) of spilled material.
	Establish work zones (hot, warm, and cold zones).
	Establish site perimeter and access controls.
	Consider evacuation or shelter-in-place, as needed.
	Monitor air quality in impacted areas to ensure responders select appropriate Personal Protective Equipment (PPE).
	Establish aircraft restrictions.
	Develop a Health and Safety Plan for response personnel.
	Run air dispersion model to determine potential evacuation zones.
Control the source of the spill	Complete emergency shut-down procedures.
	Eliminate potential flammable vapour ignition sources.
	Initiate temporary repairs to stop the leak.
	Transfer product to an approved container or facility.
	Construct barriers to prevent spill from reaching a waterbody.
Maximize protection of environmentally sensitive areas	Implement Control Points and pre-designated response strategies.
	Identify and prioritize the environmentally sensitive areas.
	Identify Resources at Risk (RAR) in spill vicinity.
	Track oil movement and develop spill trajectories.
	Conduct visual assessments (e.g., aerial overflights, ground-truthing).
	Identify, prioritize, and flag areas used as habitat by endangered species.
	Develop/implement appropriate protection strategies.



Spill Response, continued

Objectives	Strategies
Manage a coordinated response effort	Complete or confirm notifications.
	Establish Incident Command Post.
	Ensure local government and Indigenous officials are included in response organization.
	Initiate spill response Incident Action Plan.
	Ensure mobilization and tracking of response resources.
	Account for personnel and equipment
	Maintain, complete, and log all documentation related to the incident.
	Evaluate planned response objectives vs. actual response.
Contain and recover spilled material	Deploy containment boom at the spill source.
	Deploy containment boom at appropriate recovery areas.
	Conduct open water skimming.
	Develop disposal plan.
Recover and rehabilitate injured wildlife	Establish oiled wildlife reporting hotline.
	Conduct injured wildlife search and rescue operations.
	Operate wildlife rehabilitation center.
	Establish team for injured wildlife.
Remove oil from impacted areas	Conduct appropriate shoreline cleanup efforts.
	Clean oiled structures.
	Clean oiled equipment.
Keep stakeholders informed of response activities	Provide forum to obtain stakeholder input and concerns.
	Provide stakeholders with details of response actions.
	Identify stakeholder concerns and issues and address as practical.
	Provide regulatory bodies details of response actions.
Keep the public informed of response activities	Provide timely safety announcements.
	Conduct public meeting, as appropriate.
	Conduct regular news briefings.
	Manage news media access to spill response activities.

Control Points

The objective of control points is to identify pre-planned locations where spill responders can safely and effectively deploy oil spill response equipment to intercept and limit downstream movement of oil on a watercourse. Depending on the specific conditions at the time of a spill, one or more control points may be implemented as part of a response. Control points are intended to:

1. Protect sensitive areas downstream.
2. Provide locations for oil removal and collection.



Spill Response, continued

Typically, oil spill response entails multiple parallel and simultaneous activities including:

1. Source control (valve closures, clamping and pipeline drain-down)
2. Near source response (containment using berms and recovery using pumping and skimming)
Downstream response (control points)

Control points are pre-identified points along watercourse's and lakes that provide responders with key tactical information and can greatly reduce planning and implementation of containment, recovery, public protection, and wildlife protection measures during a response to a spill. Control points are typically grouped in the following categories:

1. Critical Control Points are established based on the company's asset locations and are based on the following criteria:
 - a. River crossing with easy access and staging areas.
 - b. Upstream of environmentally sensitive areas.
 - c. Upstream or proximity to communities and public infrastructure such as drinking water intakes.
 - d. Downstream of major infrastructure such as pipelines, storage, or facilities.
 - e. In areas of high-volume transportation corridors.
2. Non-Critical Control Points may include the following:
 - a. Recreational areas
 - b. Private or public land
 - c. Boat launches

When assessing the location of a control point the following factors should be considered:

1. Sites should be located downstream of the watercourse crossing and at distances that can be reached in a two- to four-hour-response time.
2. Sites should have reasonable land access.
3. Sites should have available working space for staging equipment and personnel.
4. Ideally, river flow should be slow or pooled, and/or with back eddies rather than turbulent flow conditions.
5. Ideally, sites should have public access, low banks, and should not be heavily vegetated.

Designated site-specific control points need to be reviewed at least annually. Each control point site should be visited periodically to evaluate suitability and to ensure information is accurate and complete. Old unsuitable control points should be removed, and new control points added, as a part of revisions to site specific information, as required. Control point listings should include a site description, site diagram, access description, landowner/occupant phone number, site suitability and any other information related to the site.

For a detailed list of control points, utilize the Western Canadian Spill Services (WCSS) website (<http://www.wcss.ab.ca>)



Spill Response, continued

Health and Safety

Committed to the protection of the health and safety of all spill response personnel and third parties whether members of the public or contractor personnel. The Site Safety Plan is intended to protect all personnel against potential health and safety hazards by providing information in identifying, evaluating, controlling risks, and explaining procedures to be followed during emergencies.

Provisions have been made to ensure that the health and safety of third parties, particularly members of the general public, is also protected. Third party protection procedures include evacuations, the monitoring of wind direction at the site of the release to determine the direction and spread of hazardous vapours and, if considered appropriate, conducting air monitoring in other areas where responders or third parties could be threatened.

Initial Site Assessment

The initial site assessment, hazard identification, and characterization will normally be performed by a minimum of two qualified persons outfitted in appropriate personal protective equipment. Where possible, a backup team should be immediately available. The information gained during the initial site assessment will be used to determine the site work zones (hot, warm, and cold zones) and in the development of the Site Safety Plan. The Site Safety Plan must be monitored on an ongoing basis and revised to reflect changing conditions. Personnel entering or already on site must be immediately advised of changes. The person responsible for the Site Safety Plan will ensure compliance is monitored whenever any person is within the spill response zones or any area that may be threatened as a result of the spill.

Safety Briefing

Response personnel and others authorized to enter the response area must be briefed on the content of the Site Safety Plan prior to entering the site. The person assigned to be responsible for site safety or their delegate will conduct this briefing. A copy of the Site Safety Plan must be available for reference at the spill site. Responders must also have access to the Safety Data Sheet (SDS) for the spilled product if the SDS does not form part of the Site Safety Plan.

1. SDS provide detailed hazard, precautionary, protection, and emergency information on hazardous products and may be obtained from the manufacturer or supplier of the product. Copies of SDS shall be available for all products used or handled at spill sites.
2. A copy of the appropriate SDS should be attached to the Site Safety Plan.
3. Contractors are required to have SDSs available for all products that they bring to spill sites.
4. The appropriate SDS or Emergency Response Guidebook should be referred to for spills or leaks of substances not specifically covered by this plan.

Initial Site Safety and Hazard Control Plan

An Initial Site Safety and Hazard Control Plan should be completed as soon as possible by one of the initial responders and updated as required. When completing the Initial Site Safety and Hazard Control Plan, some of the information may not apply during the initial stages of the response but may change within a short period, thereby altering the PPE and/or other requirements.



SPILL RESPONSE, continued

The Initial Site Safety and Hazard Control Plan:

1. Aids the initial first responders in assessing hazards related to the incident.
2. States the required PPE to be used.
3. Documents important health and safety information.
4. Serves as an interim "Plan" until a Site Safety Plan is developed.
5. Assigns responsibilities.
6. Identifies "site set-up" features that may be required.
7. Upon the completion and delivery of the Site Safety Plan, the Initial Site Safety and Hazard Control Plan becomes "void".

Oil Spill Removal Organization (OSRO)

OSROs are contracted organizations that have equipment, experience, and expertise to effectively respond to a hazardous or non-hazardous oil spill incident at a multitude of sites.

Contact the applicable contracted OSRO, as required. Refer to Area Specific Information for contact numbers.

Saskatchewan Petroleum Industry Release Reporting Requirements

All spills exceeding the spill/release quotas listed in the table on the following page MUST be reported immediately to the appropriate regulatory agency.

Agency	Reportable Spills	Report Type	Report to
Ministry of Energy and Resources (ER)	Immediate verbal notification is required for any release that meets or exceeds the reporting thresholds on the following page, except for the following types of incidents: 1) Contact damage to a flowline or pipeline that does not result in a break or leak. 2) Any on-site release of oil, condensate, emulsion or salt water that is less than 10m ³ or 10,000 L. 3) If a spill or other incident occurs while a product or waste is being transported. Incidents requiring notification in IRIS: 1) All incidents that meet or exceed the reporting thresholds on the following page must be reported on IRIS within 5 days . 2) All reported incidents must be followed-up with a fully detailed report on IRIS within 90 days . Note: On-site releases or contact damage that are exempt from immediate telephone notification still require ER notification using IRIS in accordance with section 3.2 of <i>Directive PNG014</i> .	Verbal	1-844-764-3637 or ER Regional Office <i>See Lead Agency Contacts below</i>
		Written	Initial report within 5 days to IRIS online reporting system Detailed report within 90 Days to IRIS online reporting system
Saskatchewan Environment	Releases of refined product if: 1) Release meets or exceeds the reporting threshold in the Saskatchewan Environment Reporting Requirements column in the Release Reporting Thresholds on the following page. 2) Any release that could pose a serious risk to the environment, public health or safety. 3) Any release with an adverse affect*	Verbal	Sask Spill Control Centre 1-800-667-7525
		Written	Within 30 Days
Saskatchewan Water Security Agency (WSA)	Immediate verbal notification of: 1) Any release that affects, or may affect waterbodies, raw water supplies or potable water sources.	Verbal	Spill reporting line 844-536-9494
Ministry of Highways (MOH) - Transportation Programs & Services	1) Any accident or incident on a provincially regulated railway.	Verbal	Within 24 hours Provincial Railway Inspector 306-787-4900
		Written	Within 48 hours rail.services@gov.sk.ca
Canadian Environmental Protection Agency (CEPA)	Environmental emergencies if: 1) The emergency involves any of the substances identified in Environment & Climate Change Canada's E2 List of regulated substances. See the website link at the bottom of the following page for more information. Note: CEPA has not identified specific reporting thresholds; however, CEPA has suggested that existing provincial reporting thresholds or TDG reporting thresholds are acceptable for use. A Schedule 8 written report through SWIM must be completed in the case of: 1) An environmental emergency involving the release of a hazardous substance that: a) Has or may have an immediate or long-term harmful effect on the environment b) Constitutes or may constitute a danger to the environment on which human life depends c) Constitutes or may constitute a danger in Canada to human life or health 2) The reasonable likelihood of an occurrence of an environmental emergency	Verbal	Sask Spill Control Centre 1-800-667-7525
		Written	As soon as possible, submit a Schedule 8 through the SWIM (Single Window Information Manager) system
Transportation of Dangerous Goods (TDG)	Substances regulated by Transportation of Dangerous Goods if: 1) A release is anticipated, or the release meets or exceeds the reporting threshold in the TDG Reporting Requirements column in the Release Reporting Thresholds table on the following page.	Verbal	911 Local Authority Spill Control Centre 1-800-667-7525
		Written	Within 30 days
Canadian Transport Emergency Centre (CANUTEC)	Loss and theft reporting: 1) CANUTEC - all loss or theft of dangerous goods materials 2) Natural Resources Canada Inspector - Class 1 explosive materials only 3) Canadian Nuclear Safety Commission - Class 7 radioactive materials only	Verbal	1) 888-226-8832 or 613-996-6666 2) 613-995-5555 3) 613-995-0479
Department of Fisheries and Oceans (DFO)	1) A release of any substance deleterious to fish into a fish bearing water body	Verbal	Sask Spill Control Centre 1-800-667-7525
Canada Energy Regulator (CER) & Transportation Safety Board (TSB)	Immediately reportable and near-miss events as defined in the Event Reporting Guidelines: 1) An incident that harms people or the environment, 2) A rupture, or 3) A toxic plume Note: Immediately reportable incidents must be reported within 3 hours to both the TSB Reporting Hotline and CER's OERS. If applicable, refer to the Federal Roles & Responsibilities chart in SECTION 5: EXTERNAL AGENCIES and the CER site section behind the AREA SPECIFIC INFORMATION tab for further regulations, definitions and reporting guidelines.	Verbal	Via Transportation Safety Board (TSB) Reporting Hotline 819-997-7887
		Written	PipelineNotifications@tsb.gc.ca
		Written	CER Online Event Reporting System (OERS) https://apps.cer-rec.gc.ca/ers/home/index
		Written	CER - Within 21 days after the day of incident/near-miss
Canadian Nuclear Safety Commission (CNSC)	All radioactive releases must be reported immediately.	Verbal	613-995-0479
		Written	Within 21 days
Indian Oil & Gas (IOGC)	Immediately reportable events on First Nation reserve lands only: 1) Any health or environment-threatening emergency or off-lease spills. 2) On-lease spills greater than 1 m ³ .	Verbal	IOGC Tsuu T'ina Office 403-292-5625

Note: Spills must be reported promptly to avoid possible prosecution.

Lead Agency Contact Numbers	
Saskatchewan	
Ministry of Energy and Resources (ER)	
Province Wide	844-764-3637
Estevan	306-637-4541
Kindersley	306-463-5400
Lloydminster	306-825-6434
Swift Current	306-778-8252
Saskatchewan Environment (Spill Control Centre)	
Province Wide	800-667-7525
Canada	
CANUTEC	
All Provinces	888-CAN-UTEC (888-226-8832) 613-996-6666
Western Canadian Spill Services (WCSS)	
Western Canada	866-541-8888
Canada Energy Regulator (CER) / Transportation Safety Board of Canada (TSB)	
TSB Reporting Hotline (Pipelines)	819-997-7887

* Definition of Adverse Affect
Is defined by the Environmental Protection & Enhancement Act (EPEA) as "impairment of or damage to the environment, human health or safety, or property." For the purpose of reporting, the industry shall use the following guidelines to assess whether the release may cause, is causing or has caused an adverse affect.
<ul style="list-style-type: none"> • Any third party impact (off-lease), e.g. crop damage, vegetation damage or livestock impact • Unrecovered spilled substance likely to contaminate surface or groundwater • Contaminated groundwater and / or surface water • Release or spill has potential for offsite odour complaints • Toxic or flammable release to air going off-site

See following page for spill/release quotas.

Saskatchewan Petroleum Industry Release Reporting Requirements

All spills exceeding the spill/release quotas listed in the table on the following page **MUST** be reported immediately to the appropriate regulatory agency.

Chemical Class	Substance / Example	T.D.G. Reporting Requirements		SK Environment / ER Reporting Requirements	
		Road, Rail or Marine	Loss or Theft	On-Site	Off-Site
Class 1 Explosives	Ammunition Nitro-glycerine	Any quantity of Packing Group II	Any quantity in Class 1.1, 1.2, and 1.3 Total quantity of 450 kg or more in Class 1.4 (except 1.4S), 1.5, or 1.6	All releases which could pose a danger or 50 kg	
Class 2.1 Flammable Gases	Methane Propane Butane Natural Gas	Any quantity	Total quantity of 450 kg or more	All releases which could pose a danger, 50 kg, or any sustained release of 10 minutes or more	
Class 2.2 Non-Flammable Gases	Compressed Air O ₂ N ₂ CO ₂		No TDG Reporting Requirements	All releases which could pose a danger or Compressed Gas: non-Halocarbon containing (including oxygen) - a sustained release of 10 minutes or more Compressed Gas: Halocarbon containing –100 kg	
Class 2.3 Toxic Gases (poisonous or corrosive)	SO ₂ Hydrogen Cyanide Nitric Acid Anhydrous Ammonia		Any quantity	Any amount	
Class 3 Flammable Liquids	Gasoline Diesel Methanol Demulsifiers Scale Inhibitors	Any quantity of Packing Group I or II More than 30 L or 30 kg of Packing Group III	Total quantity of 450 kg or more of desensitized explosives Any quantity of UN1261, Nitromethane	500 L or any subsurface loss	200 L or any subsurface loss
Class 4.1 Flammable Solids	Calcium Resinate Naphthalene Crude		Total quantity of 450 kg or more of desensitized explosives Any quantity of UN1357, Urea Nitrate, with not less than 20% water, by mass; UN3370, Urea Nitrate, Wetted, with not less than 10% water by mass		
Class 4.2 Spontaneously Combustible	Activated Carbon Potassium Sulphide Phosphorus		Total quantity of 450 kg or more in Packing Groups I or II	100 kg	25 kg
Class 4.3 Dangerous when Wet	Molten Sulphur Calcium Carbide Sodium Activated Carbon		Total quantity of 450 kg or more in Packing Groups I or II		
Class 5.1 Oxidizing Substances	Calcium Nitrate Ammonium Nitrate Bleaches	Any quantity of Packing Group I or II More than 30 L or 30 kg of Packing Group III	Total quantity of 450 kg or more in Packing Groups I or II Any quantity of UN1485, Potassium Chlorate; UN1486, Potassium Nitrate; UN 1487, Potassium Nitrate and Sodium Nitrate Mixture; UN1489, Potassium Perchlorate; UN1495, Sodium Chlorate; UN1498, Sodium Nitrate; UN1499 Sodium Nitrate and Potassium Nitrate Mixture; UN1511, Urea Hydrogen Peroxide; UN1942 Ammonia Nitrate, with not more than 0.2% combustible substances, including any organic substance calculated as carbon, to the exclusion of any other added substances; UN2014 Hydrogen Peroxide, Aqueous Solution with not less than 20% but not less than 60% hydrogen peroxide (stabilized as necessary); UN2015, Hydrogen Peroxide, Stabilized; UN2031, Nitric Acid, other than red fuming; UN3149, Hydrogen Peroxide and Peroxyacetic Acid Mixture with acid(s), water and not more than 5% peroxyacetic acid, stabilized	Packing Groups I & II 50 kg or 50 L Packing Group III 100 kg or 100 L	Packing Groups I & II 2.5 kg or 2.5 L Packing Group III 50 kg or 50 L
Class 5.2 Organic Peroxides	Methyl Ethyl Ketone Peroxide Succinic Acid Peroxide		Any quantity in Class 5.2, Type B, liquid or solid, temperature controlled	2.5 kg or 2.5 L	1 kg or 1 L
Class 6.1 Poisonous Toxic Substances	Arsenic Lead Acetate Mercuric Oxide Methanol Toxic Pesticides		Any quantity of Packing Group I	Packing Group I 2.5 kg or 2.5 L Packing Groups II & III 10 kg or 10 L	Packing Group I 1 kg or 1 L Packing Groups II & III 5 kg or 5 L
Class 6.2 Infectious Substances	Infectious Substances affecting Humans / Animals	Any quantity of Category A or B	Any quantity	All releases	
Class 7 Radioactive Substances	Uranium Plutonium Naturally Occurring Radioactive Materials (N.O.R.M.)	For packages being transported under exclusive use: (i) 10 mSv/h on the external surface (ii) 2 mSv/h on the surface of the conveyance, and (iii) 0.1 mSv/h at a distance of 2 m from the surface For packages not being transported under exclusive use: (i) 2 mSv/h on the external surface (ii) 0.1 mSv/h at a distance of 1m from the package, (iii) 2 mSv/h on the surface of the conveyance, and (iv) 0.1 mSv/h at a distance of 2m from the surface of the conveyance.	Any quantity	As per permit/approval conditions for the operation/facility. Where there is no permit/approval.	A discharge of any quantity of a Class 7 substance from a means of containment being used to store, handle or transport the substance.
Class 8 Corrosives	Acids Bases Batteries Caustic Amine	Any quantity of Packing Group I or II 30 L or 30 kg of Packing Group III	Total quantity of 450 kg or more in Packing Group I or II Any quantity of UN1796, Nitrating Acid Mixture with more than 50% nitric acid; UN1826, Nitrating Acid Mixture, Spent, with more than 50% nitric acid; UN2032, Nitric Acid, Red Fuming	10 kg or 10 L	5 kg or 5 L
Class 9.1 Miscellaneous (except and with PCB mixtures)	P.C.B. Asbestos Polystyrene Beads Gas Plant Filters Benzoic Acid Chromic Acetate Cupric Sulphate	30 L or 30 kg of Packing Group II or III, or without Packing Group	No TDG Reporting Requirements	Miscellaneous Except PCB Mixtures 100 kg	Miscellaneous Except PCB Mixtures 25 kg or 25 L
Class 9.2 Aquatic Toxic				PCB Mixtures 50 grams net PCB content	
Class 9.3 Wastes (chronic toxic)	Toxic Leachate waste containing liquid or solid metals (mercury, lead, etc.)			No TDG Reporting Requirements	10 kg or 10 L

Other SK Incidents subject to notification and reporting applicable to the petroleum industry but do not fit in the above table format

Type	Incident	Substance	Location	Description
General field operations	Fire	All	All	Any fires resulting from the operation of a licensed well, facility pipeline or flowline.
	Release or spill	Naturally Occurring Radioactive Materials (NORM) Oil by-products or oily produced sands	All	Any volume Any volume released that is not approved under GL97-02
	Blow-out	All	All	Any uncontrolled release of gases or fluid from a well
	Kicks	All	All	Any controlled diversion of gases or fluid from the well to a flare tank
Pipeline or flowline operation	Contact damage	All	All	Any contact damage to a flowline or pipeline
	Break	All	All	Any break to a flowline or pipeline
	Leak, malfunction of any equipment or a worker error resulting in the escape or release of a substance	Oil, salt water, condensate or other product	Off-Site	Any volume
		Gas containing Hydrogen Sulphide (H ₂ S)	On-Site	All releases that are > 2.0 cubic metres (m ³) of fluid
Horizontal directional drilling (pipeline/flowline installation)	Release, spill or frac-out	Drilling fluid	All	Any volume at any concentration Any volumes where: 1. The released volume exceeds 30,000 m ³ 2. The release is within a road or railway right-of-way 3. The release is within 150 metres of any dwelling
				Any volume
				Any volume
Drilling or fracturing operation	Release or spill	Drilling wastes	All	Any volume released that is not approved under GL99-01
		Fracturing wastes	All	Any volume released that is not approved under GL2000-01
Well or facility operation	Break, leak, malfunction of any equipment or intentional or unintentional action resulting in an escape or release	Oil, salt water, condensate, oil and gas waste, emulsion or product	On-Site	All volumes > 2 m ³ or 2000 L requires reporting but only volumes > 10 m ³ or 10,000 L require notification
		Refined chemical	Off-Site	Any volume
	Escape or release	Gas containing H ₂ S	On-Site	All volumes > 0.5 m ³ or 500 L
			All	Any volumes where: 1. The concentration of H ₂ S exceeds 0.1% or 1000 ppm or 1.0 mole H ₂ S/kilomole from solids, liquids or gas during production or transportation (truck or transmission via pipeline/flowline) 2. The released volume poses a danger to human health, domestic animals, wildlife or the environment

Substance	Hazard Type	On-Site	Off-Site
Emulsion	Environmental	2000 L	Any Amount
Refined chemicals used in or in association with the maintenance, production or operation of a well, facility, pipeline or flowline	Environmental	500 L	Any Amount
Oil, salt water, condensate, oil and gas waste or product	Environmental	2000 L	Any Amount
Hydrogen Sulphide (H ₂ S)	Toxic Gas	1000 ppm or 1 mole/Kmole	
Drilling wastes, frac wastes, oil byproducts (Oily produced Sands)	Environmental	2000 L	Any Amount
Plant-based oils and fuels (Not Hazard Class 3), (e.g. Canola, sunflower, linseed oils, bio-diesel)	Environmental	500 L	250 L
Glycols (inhibited and uninhibited) (e.g. antifreeze, heat transfer fluids)	Environmental	100 L	50 L
Non-Class 3 Petroleum Substances (e.g. new and used lubricating oils, mineral oils, hydraulic fluids)	Environmental	500 L	200 L
Industrial Wastes	Environmental	1000 Kg or 1000 L	500 Kg or 500 L
Sewage	Environmental	N/A	300 L

For all other reportable substances/quantities, please refer to company SDS sheets for more information.

List of Environment & Climate Change Canada's E2 Regulated Substances: <http://gazette.gc.ca/pr-pr/p2/2019/2019-03-06/html/sor-dors51-eng.html>

Manitoba Petroleum Industry Release Reporting Requirements

All spills exceeding the spill/release quotas listed in the table on the following page MUST be reported immediately to the appropriate regulatory agency.

Agency	Reportable Spills	Report Type	Report to
Manitoba Economic Development, Investment and Trade (EDIT) – Resource Development (Petroleum)	Substances regulated by Resource Development (Petroleum) if: 1) The spill occurs on or spreads to land off the well-site or the site of the oil and gas facility. 2) The product released is not a refined product. 3) Any liquid spill greater than 0.5 m ³ . 4) Any release or imminent release of a contaminant that may pose a risk to public health or the environment.	Verbal	24 Hour Number 800-223-5215
		Written	Within 7 days
Manitoba Environment, Climate and Parks	Releases of refined product if: 1) Release meets or exceeds the reporting threshold in the Manitoba Environment Reporting Requirements column in the Release Reporting Thresholds table on the following page. 2) Any release that enters a main watercourse or navigate water body. 3) Any release that occurs while under transport. 4) The volume of product exceeds 100 L.	Verbal	24 Hour Number 204-944-4888 / 855-944-4888
		Written	Within 7 days
Canadian Environmental Protection Agency (CEPA)	Environmental emergencies if: 1) The emergency involves any of the substances identified in Environment & Climate Change Canada's E2 List of regulated substances. See the website link at the bottom of the following page for more information. Note: CEPA has not identified specific reporting thresholds; however, CEPA has suggested that existing provincial reporting thresholds or TDG reporting thresholds are acceptable for use. A Schedule 8 written report through SWIM must be completed in the case of: 1) An environmental emergency involving the release of a hazardous substance that: a) Has or may have an immediate or long-term harmful effect on the environment b) Constitutes or may constitute a danger to the environment on which human life depends c) Constitutes or may constitute a danger in Canada to human life or health 2) The reasonable likelihood of an occurrence of an environmental emergency	Verbal	24 Hour Number 204-944-4888 / 855-944-4888
		Written	As soon as possible, submit a Schedule 8 through the SWIM (Single Window Information Manager) system
Transportation Dangerous Goods (TDG)	Substances regulated by Transportation of Dangerous Goods if: 1) A release is anticipated, or the release meets or exceeds the reporting threshold in the TDG Reporting Requirements column in the Release Reporting Thresholds table on the following page.	Verbal	911 Local Authority Dangerous Goods SD 24 Hour Number 204-944-4888 / 855-944-4888
		Written	Within 30 days
Canadian Transport Emergency Centre (CANUTEC)	Loss and theft reporting: 1) CANUTEC - all loss or theft of dangerous goods materials 2) Natural Resources Canada Inspector - Class 1 explosive materials only 3) Canadian Nuclear Safety Commission - Class 7 radioactive materials only	Verbal	1) 888-226-8832 or 613-996-6666 2) 613-995-5555 3) 613-995-0479
Department of Fisheries and Oceans (DFO)	1) A release of any substance deleterious to fish into a fish bearing water body	Verbal	SD 24 Hour Number 204-944-4888
Canada Energy Regulator (CER) & Transportation Safety Board (TSB)	Immediately reportable and near-miss events as defined in the Event Reporting Guidelines: 1) An incident that harms people or the environment, 2) A rupture, or 3) A toxic plume Note: Immediately reportable incidents must be reported within 3 hours to both the TSB Reporting Hotline and CER's OERS. If applicable, refer to the Federal Roles & Responsibilities chart in SECTION 5: EXTERNAL AGENCIES and the CER site section behind the AREA SPECIFIC INFORMATION tab for further regulations, definitions and reporting guidelines.	Verbal	Via Transportation Safety Board (TSB) Reporting Hotline 819-997-7887
		Written	PipelineNotifications@tsb.gc.ca
		Written	CER Online Event Reporting System (OERS) https://apps.cer-rec.gc.ca/ers/home/index
		Written	CER - Within 21 days after the day of incident/near-miss
		Written	TSB - Within 30 days after the day of the incident/near-miss
Canadian Nuclear Safety Commission (CNSC)	All radioactive releases must be reported immediately.	Verbal	613-995-0479
		Written	Within 21 days
Indian Oil & Gas (IOGC)	Immediately reportable events on First Nation reserve lands only: 1) Any health or environment-threatening emergency or off-lease spills. 2) On-lease spills greater than 1m ³ .	Verbal	IOGC Tsuu T'ina Office 403-292-5625

Note: Spills must be reported promptly to avoid possible prosecution.

Lead Agency Contact Numbers	
Manitoba	
Manitoba Economic Development, Investment and Trade (EDIT) – Resource Development (Petroleum)	
Province Wide	800-223-5215
Manitoba Environment, Climate and Parks (Spill Control Centre)	
Province Wide	855-944-4888 204-944-4888
Canada	
CANUTEC	
All Provinces	888-CAN-UTEC (888-226-8832) 613-996-6666
Canada Energy Regulator (CER) / Transportation Safety Board of Canada (TSB)	
TSB Reporting Hotline (Pipelines)	819-997-7887

See following page for spill/release quotas.

Manitoba Petroleum Industry Release Reporting Requirements

All spills exceeding the spill/release quotas listed in the table on the following page MUST be reported immediately to the appropriate regulatory agency.

Chemical Class	Substance / Example	T.D.G. Reporting Requirements		Manitoba Environment, Climate and Parks Reporting Requirements	
		Road, Rail or Marine	Loss or Theft		
Other Released Substances	Hydraulic Oil	No TDG Reporting Requirements		100 L on-site Any release off-site (Report to district office and notify landowner within 12 hours)	
	Methanol	See Class 3 & 6.1			
	Natural Gas	See Class 2.1			
	Crude Oil / Emulsion	See Class 3			
	Produced / Salt Water	No TDG Reporting Requirements			
	Condensate	See Class 3			
	Glycol	No TDG Reporting Requirements			
Class 1 Explosives	Ammunition Nitro-glycerine	Any quantity of Packing Group II	Any quantity in Class 1.1, 1.2, and 1.3 Total quantity of 450 kg or more in Class 1.4 (except 1.4S), 1.5, or 1.6	All releases	
Class 2.1 Flammable Gases	H ₂ S Methane Propane Butane Natural Gas	Any quantity	Total quantity of 450 kg or more	100 L container capacity	
Class 2.2 Non-Flammable Gases	Compressed Air O ₂ N ₂ CO ₂		No TDG Reporting Requirements		
Class 2.3 Toxic Gases (poisonous or corrosive)	H ₂ S SO ₂ Hydrogen Cyanide Nitric Acid Anhydrous Ammonia		Any quantity		All releases
Class 3 Flammable Liquids	Gasoline Diesel Methanol Demulsifiers Scale Inhibitors Lube Oil	Any quantity of Packing Group I or II More than 30 L or 30 kg of Packing Group III	Total quantity of 450 kg or more of desensitized explosives Any quantity of UN1261, Nitromethane	100 L	
Class 4.1 Flammable Solids	Calcium Resinate Naphthalene Crude		Total quantity of 450 kg or more of desensitized explosives Any quantity of UN1357, Urea Nitrate, with not less than 20% water, by mass; UN3370, Urea Nitrate, Wetted, with not less than 10% water by mass	1 kg	
Class 4.2 Spontaneously Combustible	Activated Carbon Potassium Sulphide Phosphorus		Total quantity of 450 kg or more in Packing Groups I or II		
Class 4.3 Dangerous when Wet	Molten Sulphur Calcium Carbide Sodium Activated Carbon		Total quantity of 450 kg or more in Packing Groups I or II		
Class 5.1 Oxidizing Substances	Calcium Nitrate Ammonium Nitrate Bleaches		Any quantity of Packing Group I or II More than 30 L or 30 kg of Packing Group III	Total quantity of 450 kg or more in Packing Groups I or II Any quantity of UN1485, Potassium Chlorate; UN1486, Potassium Nitrate; UN 1487, Potassium Nitrate and Sodium Nitrate Mixture; UN1489, Potassium Perchlorate; UN1495, Sodium Chlorate; UN1498, Sodium Nitrate; UN1499 Sodium Nitrate and Potassium Nitrate Mixture; UN1511, Urea Hydrogen Peroxide; UN1942 Ammonia Nitrate, with not more than 0.2% combustible substances, including any organic substance calculated as carbon, to the exclusion of any other added substances; UN2014 Hydrogen Peroxide, Aqueous Solution with not less than 20% but not less than 60% hydrogen peroxide (stabilized as necessary); UN2015, Hydrogen Peroxide, Stabilized; UN2031, Nitric Acid, other than red fuming; UN3149, Hydrogen Peroxide and Peroxyacetic Acid Mixture with acid(s), water and not more than 5% peroxyacetic acid, Stabilized	1 kg or 1 L for packaging groups I & II 50 kg or 50 L for packaging group III
Class 5.2 Organic Peroxides	Methyl Ethyl Ketone Peroxide Succinic Acid Peroxide			Any quantity in Class 5.2, Type B, liquid or solid, temperature controlled	1 kg or 1 L
Class 6.1 Poisonous Toxic Substances	Arsenic Lead Acetate Mercuric Oxide Methanol Toxic Pesticides			Any quantity of Packing Group I	1 kg or 1 L for packaging group I 5 kg or 5 L for packaging groups II & III
Class 6.2 Infectious Substances	Infectious Substances affecting Humans / Animals	Any quantity of Category A or B	Any quantity	All releases	
Class 7 Radioactive Substances	Uranium Plutonium Naturally Occurring Radioactive Materials (N.O.R.M.)	For packages being transported under exclusive use: (i) 10 mSv/h on the external surface (ii) 2 mSv/h on the surface of the conveyance, and (iii) 0.1 mSv/h at a distance of 2 m from the surface For packages not being transported under exclusive use: (i) 2 mSv/h on the external surface (ii) 0.1 mSv/h at a distance of 1 m from the package, (iii) 2 mSv/h on the surface of the conveyance, and (iv) 0.1 mSv/h at a distance of 2 m from the surface of the conveyance.	Any quantity	Discharge or radiation level exceeding 10 mSv/h at package surface & 200 uSv/h, 1m from the package surface	
Class 8 Corrosives	Acids Bases Batteries Caustic Amine	Any quantity of Packing Group I or II 30 L or 30 kg of Packing Group III	Total quantity of 450 kg or more in Packing Group I or II Any quantity of UN1796, Nitrating Acid Mixture with more than 50% nitric acid; UN1826, Nitrating Acid Mixture, Spent, with more than 50% nitric acid; UN2032, Nitric Acid, Red Fuming;	5 kg or 5 L	
Class 9 Miscellaneous Products, Substances & Organisms, Environmentally Hazardous Substances	P.C.B. Asbestos Polystyrene Beads Gas Plant Filters Benzoic Acid Chromic Acetate Cupric Sulphate	30 L or 30 kg of Packing Group II or III, or without Packing Group	No TDG Reporting Requirements	50 kg (except PCB mixture = 500 grams)	
Class 9.1 Miscellaneous (except and with PCB mixtures)				1 kg or 1 L	
Class 9.2 Aquatic Toxic				5 kg or 5 L	
Class 9.3 Wastes (chronic toxic)					

For all other reportable substances/quantities, please refer to company SDS sheets for more information.

List of Environment & Climate Change Canada's E2 Regulated Substances: <http://gazette.gc.ca/rp-pr/p2/2019/2019-03-06/html/sor-dors51-eng.html>

North Dakota Petroleum Industry Release Reporting Requirements

Agency	Reportable Spills	Report Type	Report to
N.D. Industrial Commission (NDIC)*	Immediate Hazmat Spill/Release Reporting Criteria 1) Any spill/release that has an impact, or potential impact, to public health 2) Waterways impacted/threatened 3) Injuries or deaths 4) Evacuations, or potential need for 5) Any spill/release that has immediate impact to wildlife North Dakota uses a whole-of-government approach in the state's new Unified Spill/Tier II reporting system tool. All incidents must be reported verbally through their 24 hour spill reporting line as well as written online through the Hazconnect Unified Spill Reporting System. * Dependent on the situation, once a spill/release is reported, electronic notification to one of the listed agencies may take place:	Verbal	As soon as possible 1-833-997-7455
N.D. Dept. of Environmental Quality (NDDEQ) *		Written	Within 24 hours of incident www.spill.nd.gov To submit a written report, you must first create an account with Hazconnect (https://northdakota.hazconnect.com/Account/Login.aspx)
N.D. Dept. of Emergency Services (NDDSES)* / Tribal Manager*			
N.D. Game and Fish Department (NDGFD)*			
N.D. Dept. of Health (NDDoH)*			
N.D. Dept. of Agriculture*			
N.D. State Fire Marshal*			
N.D. Parks and Recreation*			
N.D. Public Service Commission*			
U.S. Fish and Wildlife*			
U.S. Army Corps of Engineers*			
North Dakota State Historic Preservation Office (SHPO)	As soon as possible, report: 1) Any spill that may potentially impact culturally, historically, or archaeological sensitive areas.	Verbal	701-328-2666
North Dakota First Nations	Immediately report: 1) Any spill that which enters, or threatens to enter waterbodies within or flow through first nations lands. 2) Any spill that poses an impact to first nations lands or properties.	Verbal	If applicable, emergency contact information can be found in the Area Specific Information.

Specific minimum quantities for mandatory reporting of spills have not been established in the state of North Dakota. All spills which may potentially impact waters of the state, either surface water or ground water, must be reported. This includes all substances, not just "hazardous materials." These may include "non toxic" substances such as molasses or salt. These may not be immediately harmful to human health, but they may impact aquatic life or soil fertility.

Note: Spills must be reported promptly to avoid possible prosecution.

North Dakota Spill Reporting Form Information:

Oilfield Related Incident Report Form - https://www.dmr.nd.gov/oilgas/spills/eirform.asp#Oilfield_Form

This form is only for RCRA-exempt releases in the oilfield. This will generally include:

- Produced fluids such as crude oil, water, oil/water emulsion, drilling fluids and cuttings, well completion, treatment, and stimulation fluids, basic sediment and water and other tank bottoms from storage facilities and vessels and impoundments that hold product and exempt waste, workover wastes, packing fluids, pipe scale and other solids, hydrocarbon-bearing soil, pigging wastes from gathering lines, and oil reclamation wastes.
- Gasses removed from the production stream, gas plant dehydration and sweetening wastes, and cooling tower blowdown.

Please Note:

- Releases of crude oil or produced water from truck transport are not exempt and should use the General Environmental Incident Report Form link below.
- Releases of crude oil or other non-gaseous petroleum products from transportation pipelines are not exempt and should use the General Environmental Incident Report Form link below.
- Releases of non-oilfield-produced substances, even when released on an oil lease, are not exempt and should use the General Environmental Incident Report Form link below. This would include spills such as fuel for rig motors, acid for well stimulation, etc.

**General Environmental Incident Report Form - https://www.dmr.nd.gov/oilgas/spills/eirform.asp#General_Form
(Includes Non-exempt Oilfield Related Incidents)**

This form should be used for any environmental incident or release that is not exempt under the RCRA oilfield exemptions. This will generally include:

- Any incident which may potentially have adverse effects to human health or the environment.
- Any incident or spill which may potentially result in pollution of waters of the state, either surface water or ground water.
- Specific minimum quantities for mandatory reporting of spills have not been established. All incidents which may potentially impact human health or safety, waters of the state, either surface water or ground water, or other impacts to the environment, must be reported.
- All substances are included, not just "hazardous materials." Recent examples that a person may not normally think of as having a potential impact to the environment, include "non toxic" substances such as molasses or salt. These may not be immediately harmful to human health, but they may impact aquatic life or soil fertility.

Please Note:

- Sometimes an environmental incident does not actually result in a release to the environment, but should still be reported. Examples might include the loss of a sealed radiation source or a traffic accident involving hazardous chemicals, even if the containers did not break open.

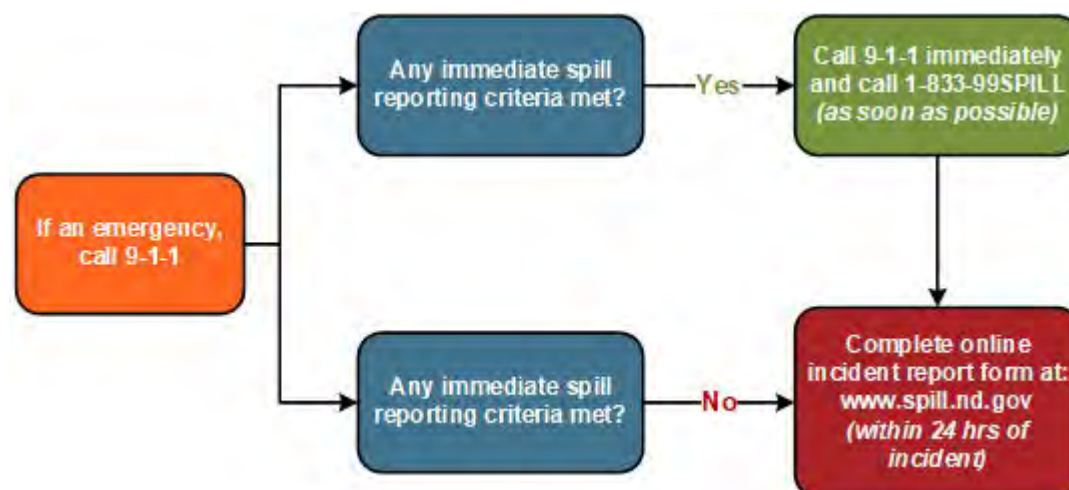

U.S. Federal Petroleum Industry Release Reporting Requirements

U.S. Federal

Agency	Reportable Spills	Report Type	Report to
Environmental Protection Agency (EPA)	<p>Immediately report:</p> <p>Any impact to water that:</p> <ol style="list-style-type: none"> 1) Causes a sheen or discoloration on the surface of a body of water; 2) Violates applicable water quality standards; or 3) Causes a sludge or emulsion to be deposited beneath the surface of the water or on adjoining shorelines. <p><i>40 CFR § 110.3 Clean Water Act</i></p>	Verbal	National Response Center (NRC) 1-800-424-8802
	<p>Immediately report:</p> <p>A release of an EPCRA extremely hazardous substance (EHS) that is released off lease in quantities equal to or greater than their Reportable Quantities (RQs) within a 24 hour period.</p> <p><i>Appendix A & B of 40 CFR Part 355</i></p> <p>Refer to the EPA's "Consolidated "Lists of Lists" for EPCRA & CERCLA RQs. https://www.epa.gov/epcra/consolidated-list-lists</p> <p>Note: EPCRA extremely hazardous substances that are also CERCLA hazardous substances have the same RQ as under CERCLA. EPCRA extremely hazardous substances that are not listed under CERCLA have an RQ equal to their TPQ under EPCRA.</p> <p><i>The petroleum exclusion does not apply to EPCRA releases.</i></p>	Verbal	State Emergency Response Commission (SERC) Local Emergency Planning Committee (LEPC) Tribal Emergency Response Commission (TERC) Or 911 for Transportation Incidents
	<p>Immediately report:</p> <p>CERCLA hazardous substance releases that are not part of the Petroleum Exclusion that are released into the environment (not contained in a building), in quantities equal to or greater than their Reportable Quantities (RQs) within a 24 hour period.</p> <p><i>40 CFR Part 302.4</i></p> <p>Refer to the EPA's "Consolidated "Lists of Lists" for EPCRA & CERCLA RQs. https://www.epa.gov/epcra/consolidated-list-lists</p> <p>Note: When a determination is made to regulate a substance under the Clean Air Act (CAA), Clean Water Act (CWA), Resource Conservation Recovery Act (RCRA) or Toxic Substances Control Act (TSCA), it automatically becomes a CERCLA hazardous substance and will be added to 40 CFR 302.4.</p> <p><i>CERCLA Petroleum Exclusion: These substances include petroleum, meaning crude oil or any fraction thereof which is not specifically listed as a hazardous substance. Natural and synthetic gases, or mixtures of natural and synthetic gases are also excluded. If a release of one of these substances occurs, CERCLA notification is not required. EPA interprets petroleum as including those amounts of hazardous substances, such as benzene, that are indigenous to crude oil or its fractions or that are normally added during the refining process. Such amounts are part of the petroleum and are excluded from regulation under CERCLA. Hazardous substances added to the petroleum or increased in concentration solely as a result of contamination during use are not part of the petroleum and are not excluded from regulation under CERCLA.</i></p>	Verbal	National Response Center (NRC) 1-800-424-8802 & State Emergency Response Commission (SERC) Local Emergency Planning Committee (LEPC) Tribal Emergency Response Commission (TERC) Or 911 for Transportation Incidents
	<p>A facility that is subject to the Spill Control, Prevention & Countermeasure (SPCC) rule and discharges to navigable waters or adjoining shorelines:</p> <ol style="list-style-type: none"> 1) More than 1,000 US gallons of oil in a single discharge or 2) More than 42 U.S. Gallons of oil in each of two discharges within any twelve-month period <p><i>40 CFR Part 112.4</i></p> <p>Note: When determining the applicability of this SPCC reporting requirement, the gallon amount(s) specified refer to the amount of oil that actually reaches navigable waters or adjoining shorelines, not the total amount of oil spilled.</p>	Written	Within 60 days to the EPA Regional Administrator https://www.epa.gov/oil-spills-prevention-and-preparedness-regulations/contact-us-about-oil-spill-prevention-and
	<p>Immediately report:</p> <p>An event that involves a release of gas from a pipeline, gas from an underground natural gas storage facility (UNGSF), liquefied natural gas, liquefied petroleum gas, refrigerant gas, or gas from an LNG facility, and that results in one or more of the following consequences:</p> <ol style="list-style-type: none"> 1) A death, or personal injury necessitating in-patient hospitalization; 2) Estimated property damage of \$50,000 or more; 3) Unintentional estimated gas loss of three million cubic feet or more; 4) Results in an emergency shutdown of an LNG facility or a UNGSF; 5) Is significant in the judgment of the operator, even though it did not meet the above requirements. <p><i>49 CFR § 191.5 & 49 CFR § 191.3</i></p> <p>Note: A follow up report will be required 48 hours after reporting the incident to confirm amount of product released, an estimate of the number of fatalities and injuries, and all other significant facts.</p>	Verbal	National Response Center (NRC) 1-800-424-8802
Pipeline & Hazardous Materials Safety Administration (PHMSA)	<p>An event that involves a release of a hazardous liquid or carbon dioxide that results in one or more of the following consequences:</p> <ol style="list-style-type: none"> 1) Caused a death or a personal injury requiring hospitalization; 2) Resulted in either a fire or explosion not intentionally set by the operator; 3) Caused estimated property damage, including cost of cleanup and recovery, value of lost product, and damage to the property of the operator or others, or both, exceeding \$50,000; 4) Resulted in pollution of any stream, river, lake, reservoir, or other similar body of water that violated applicable water quality standards, caused a discoloration of the surface of the water or adjoining shoreline, or deposited a sludge or emulsion beneath the surface of the water or upon adjoining shorelines; or 5) Is significant in the judgment of the operator, even though it did not meet the above requirements. <p><i>49 CFR § 195.52</i></p> <p>Note: A follow up report will be required 48 hours after reporting the incident to confirm amount of product released, an estimate of the number of fatalities and injuries, and all other significant facts.</p>	Verbal	National Response Center (NRC) 1-800-424-8802
	<p>An accident report (DOT Form 7000-1) is required for all conditions under the "release of a hazardous liquid or carbon dioxide" above that require a verbal report as well as for any release of 5 gallons or more of hazardous liquid or carbon dioxide unless it was a result of a pipeline maintenance activity and it was confined to company property or the pipeline right of way and was cleaned up promptly.</p> <p><i>49 CFR § 195.50</i></p>	Written	As soon as practicable but not later than 30 days

State Emergency Response Commission (SERC)

To find the appropriate contact for the SERC in your state: <https://www.epa.gov/epcra/state-emergency-response-commissions-contacts>

Local Emergency Planning Committee (LEPC)

Contact your SERC in order to identify the appropriate LEPC contacts.

Tribal Emergency Response Commission (TERC)

Contact your SERC in order to identify the appropriate TERC contacts.

See following page for additional U.S. Federal Release Reporting Requirements

Federal spill reporting document updated March 2023

U.S. Federal Petroleum Industry Release Reporting Requirements

U.S. Federal

Agency	Reportable Spills	Report Type	Report to
Pipeline & Hazardous Materials Safety Administration (PHMSA) - Department of Transportation (DOT)	Whenever an incident occurs during the course of transportation (including loading, unloading, and temporary storage) that as a direct result of a hazardous material : 1) A person is killed; 2) A person receives an injury requiring admittance to a hospital; 3) The general public is evacuated for one hour or more; 4) A major transportation artery or facility is closed or shut down for one hour or more; or 5) The operational flight pattern or routine of an aircraft is altered; 6) Fire, breakage, spillage, or suspected radioactive contamination occurs involving a radioactive material; 7) Fire, breakage, spillage, or suspected contamination occurs involving an infectious substance other than a regulated medical waste; 8) A release of a marine pollutant occurs in a quantity exceeding 450 L (119 gallons) for a liquid or 400 kg (882 pounds) for a solid; 9) A situation exists of such a nature (e.g., a continuing danger to life exists at the scene of the incident) that, in the judgment of the person in possession of the hazardous material, it should be reported even though it does not meet the criteria above; 10) During transportation by aircraft, a fire, violent rupture, explosion or dangerous evolution of heat (i.e., an amount of heat sufficient to be dangerous to packaging or personal safety to include charring of packaging, melting of packaging, scorching of packaging, or other evidence) occurs as a direct result of a battery or battery-powered device. <i>49 CFR § 171.15</i>	Verbal	National Response Center (NRC) 1-800-424-8802
	A Hazardous Materials Incident Report (DOT Form 5800-1) is required for all conditions under the "release of hazardous materials during a transportation incident" above that require a verbal report as well as: 1) An unintentional release of a hazardous material or the discharge of any quantity of hazardous waste; 2) A specification cargo tank with a capacity of 1,000 gallons or greater containing any hazardous material suffers structural damage to the lading retention system or damage that requires repair to a system intended to protect the lading retention system, even if there is no release of hazardous material; 3) An undeclared hazardous material is discovered; or 4) A fire, violent rupture, explosion or dangerous evolution of heat (i.e., an amount of heat sufficient to be dangerous to packaging or personal safety to include charring of packaging, melting of packaging, scorching of packaging, or other evidence) occurs as a direct result of a battery or battery-powered device. <i>49 CFR § 171.16</i>	Written	Within 30 Days to the Pipeline and Hazardous Materials Safety Administration, Department of Transportation Refer to Section 4: Transportation Incidents for the DOT Form 5800-1
Department of the Interior - Bureau of Land Management	The BLM must be notified of any of the following Major Undesirable Events (MUEs) on public lands: 1) A release of 100 bbls or more of oil, saltwater or toxic liquid that is not entirely contained to the facility. 2) A release of 500 thousand or more cubic feet of gas. 3) Any fire that consumes more than 100 bbls of liquid or 500 thousand cubic feet of gas. 4) Any release or fire that occurs in a sensitive area (parks, recreation sites, wildlife refuges, lakes, reservoirs, streams, or urban or suburban areas). 5) Any accident that involves a fatal injury. 6) Every blowout (loss of control of any well).	Verbal	As soon as practicable but not more than 24 hours reported to the BLM Field Office https://www.blm.gov/office/national-office
	A written report is required for all of the MUEs requiring a verbal report listed above as well as the following: 1) A release of 100 bbls or more of oil, saltwater or toxic liquid that is entirely contained to the facility. 2) A release of at least 10 bbls but less than 100 bbls or more of oil, saltwater or toxic liquid in non-sensitive areas. 3) A release of at least 50 thousand cubic feet of gas but less than 500 thousand cubic feet of gas in non-sensitive areas. 4) Any fire which consumes the volumes in lines 2 & 3 above. 5) Each accident involving a major or life threatening injury.	Written	Within 15 Days to the BLM Field Office https://www.blm.gov/office/national-office
Department of Agriculture - Forest Service	Notify the USDA Forest Service District of any of the following incidents on USDA Forest Service property: 1) Any impact to water. 2) A release of 100 bbls or more of oil, saltwater or toxic liquid that is not entirely contained to the facility. 3) A release of 500 thousand or more cubic feet of gas.	Verbal	As soon as practicable but not more than 24 hours reported to the USDA Forest Service District Office

When reporting to the National Response Center (NRC) be prepared to provide the following:

- Your name, location, organization, and telephone number
- Name and address of the party responsible for the incident; or name of the carrier or vessel, the railcar/truck number, or other identifying information
- Date and time of the incident
- Location of the incident
- Source and cause of the release or spill
- Types of material(s) released or spilled
- Quantity of materials released or spilled
- Medium (e.g. land, water) affected by release or spill
- Danger or threat posed by the release or spill
- Number and types of injuries or fatalities (if any)
- Weather conditions at the incident location
- Whether an evacuation has occurred
- Other agencies notified or about to be notified
- Any other information that may help emergency personnel respond to the incident

When reporting to the SERC, LEPC & TERC be prepared to provide the following:

- Chemical name or identity of any substance involved in the release
 - Whether the substance is an EPCRA and / or CERCLA substance
 - Estimate of the quantity of any such substance that was released into the environment
 - Time and duration of release
 - Medium or media into which the release occurred
 - Any known or anticipated acute or chronic health risks associated with the emergency and, where appropriate, advice regarding medical attention necessary for exposed individuals
 - Proper precautions to take as a result of the release, including evacuation (unless such information is readily available to the community emergency coordinator pursuant to the emergency plan)
 - Name and telephone number of the individual (or individuals) to be contacted for further information
- The written report will need to contain an update to the above information as well as:
- Actions taken to respond and contain the release.
 - Any known or anticipated acute or chronic health risks associated with the release.
 - Where appropriate, advice regarding medical attention necessary for exposed individuals.

When reporting a discharge under the SPCC rule to the EPA be prepared to provide the following:

- Name and location of the facility
- Owner/operator name
- Maximum storage/handling capacity of the facility and normal daily throughput
- Corrective actions and countermeasures taken, including descriptions of equipment repairs and replacements
- Adequate description of the facility, including maps, flow diagrams, and topographical maps, as necessary
- Cause of the discharge to navigable waters, including a failure analysis
- Failure analysis of the system where the discharge occurred
- Additional preventive measures taken or planned to take to minimize discharge reoccurrence

The written report for the BLM should contain:

- The date and time of occurrence, and the date and time reported to USGS;
- The location where the incident occurred, including surface ownership and lease number;
- The specific nature and cause of the incident;
- A description of the resultant damage;
- The action taken and the length of time required for control of the incident, for containing the discharged fluids, and for subsequent cleanup;
- The estimated volumes discharged and the volumes lost;
- The cause of death when fatal injuries are involved;
- Actions that have been or will be taken to prevent a recurrence of the incident and
- Other Federal or State agencies notified of the incident.



Containment and Recovery

Understanding Environments – Ground and Water

A spill can occur in several different environments. The type of environment will influence the most appropriate technique to be used for the response strategy, while the fate of oil will be influenced by many other situational and local factors. The response can be complicated due to geophysical and environmental factors that can affect the oil spill's behavior.

	Ground	
	Permeable Ground	Impermeable Ground
Understand oil behavior:	Oil on permeable ground will flow in both horizontal and vertical directions. Penetration of ground will depend on the oil type and the porosity and permeability of the surface materials.	Oil on impermeable ground will either remain relatively static on the terrain or follow the path of least resistance if a slope is present. It is likely to collect in depressions and watercourses.
Identify resources at risk:	Examples of resources needing protection include: <ul style="list-style-type: none"> • Non-vegetated: mud/silt; sand; pebble/boulders. • Vegetated: grassland; forest; wetland. 	Examples of resources needing protection include: <ul style="list-style-type: none"> • Drainage systems • Watercourses • Utilities
Response Considerations:	<ul style="list-style-type: none"> • Penetration of soil below the uppermost layer must be minimized. • Prevent oil from entering areas with ground water. • Drains and inlets should be blocked. 	<ul style="list-style-type: none"> • Oil should be contained as soon as possible. • Any flowing oil should be intercepted quickly to prevent further contamination of the surface. • Drains and inlets should be blocked.

Permeable Ground



Impermeable Ground





Containment and Recovery, continued

	Water	
	Static Water	Moving Water
Understand oil behavior:	Oil on static water will float, spreading to form a thin surface layer. Water is rarely truly “static”, with wind-induced waves causing spilled oil to drift.	Oil can be rapidly transported by moving water, following the direction of both wind and currents. The oil generally spreads to form a thin surface layer and will also be subjected to significant weathering processes.
Identify resources at risk:	Examples of resources needing protection include: <ul style="list-style-type: none">• Ponds• Lakes• Reservoirs	Examples of resources needing protection include: <ul style="list-style-type: none">• Rivers• Streams• Water intakes• Fishing areas
Response Considerations:	<ul style="list-style-type: none">• Prevent oil from spreading beyond the water body and contaminating further surfaces.• Consider impact of oil moving into vegetated areas such, as reed beds. This will act to trap oil making it more difficult to recover.	<ul style="list-style-type: none">• Oil should be contained as soon as possible and collected.• Intercept oil flowing downstream to prevent further contamination, while protecting resources at risk.

Static Water



Moving Water





Containment and Recovery, continued

Containment of Spilled Product

On Permeable Ground

Permeable ground will pose challenges to the containment of oil as it flows in both a horizontal and vertical direction and will travel with the direction of groundwater flow once it is reached.

1. Response Priorities

When responding to a spill on permeable surfaces, it is important to minimize the amount of oil that can penetrate below the surface; this should require the oil to be spread over a large surface area in the attempt to reduce head pressure on the surface to prevent penetration. This may well be the preferable option compared to long-term operations of subsoil and groundwater clean-up.

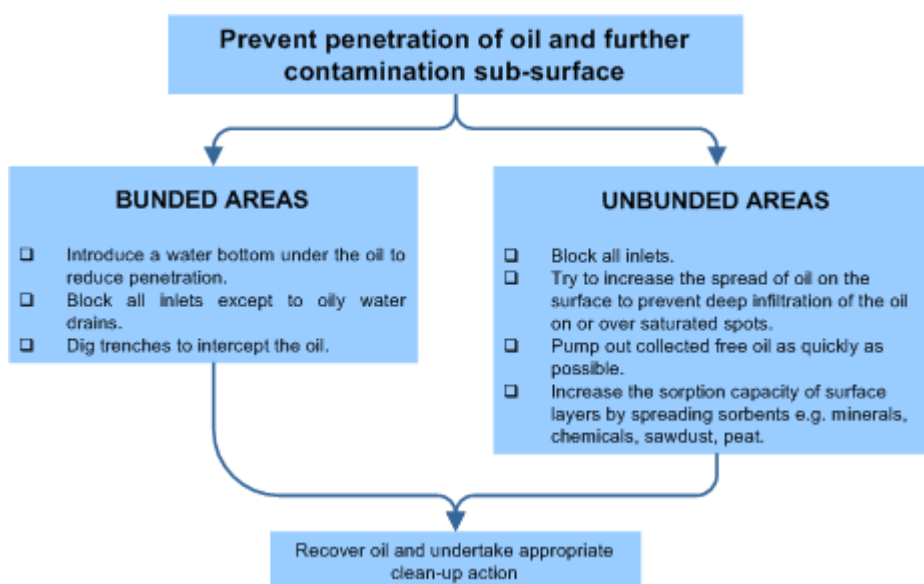

2. Retention Capacities in Permeable Surfaces

Each type of permeable surface will allow oil to permeate at different rates and will retain oil at varying capacities. Although the pore spaces in coarser soils are larger, oil will flow through more readily (due to gravity) thus giving a lower retention capacity.

Finely packed sediments retain the oil in two ways; first, the oil molecules cannot pass so easily between the particles due to their size and secondly because the forces associated with capillary action hold the oil in the pore spaces.

Surface area is also a factor in retention capacities; small grain sediments have a higher surface area and therefore hold more oil on the surface of the grains than larger grained sediments.



Containment and Recovery, continued

Surface Type	Capacity (ltrs/m ³)
Stones / Coarse Gravel	5
Gravel / Coarse Sand	8
Coarse Sand / Medium Sand	15
Medium Sand / Fine Sand	25
Fine Sand / Silt	40

Note: Groundwater movement is very slow, usually between 0.5 m and 1.5 m per day. If oil reaches below subsurface layers, a study of the underlying hydrogeology to identify the most optimal location for the recovery of oil. Different recovery methods can then be put in place, preventing both the further spread of the oil, and flushing from the groundwater system.

On Impermeable Ground

Spill on impermeable ground will remain static until it is recovered, unless a gradient is present that may cause it to spread.

1. Response Priorities

If spills on impermeable ground, the response should first prevent the oil from further spreading and potentially contaminating other surface areas. Once contained, the oil will then need to be recovered through either manual or mechanical methods.

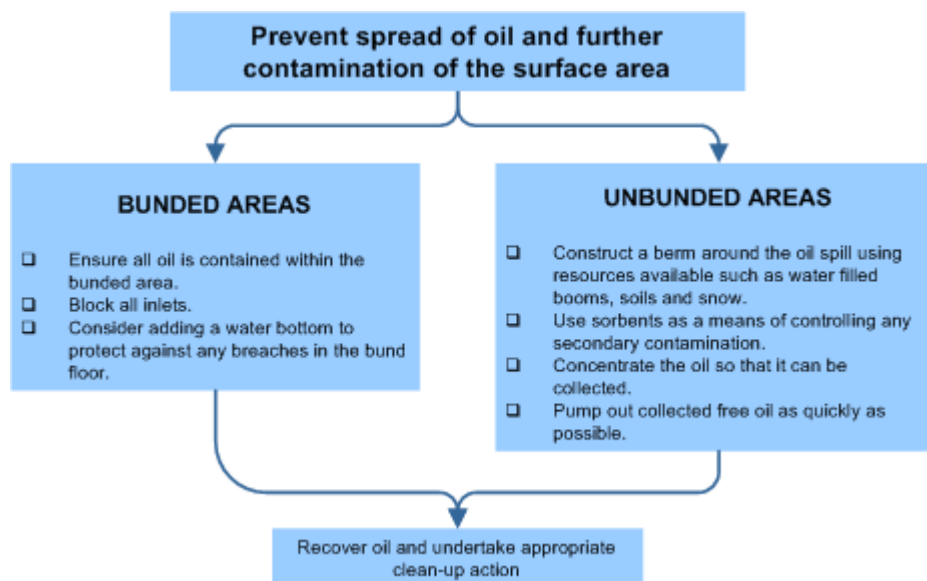



Containment and Recovery, continued

2. Spills in Urban Areas

Urban and built-up areas will contain a vast amount of man-made surface areas sitting alongside natural environments. These man-made surface areas will often be impermeable in nature, so prevention of spread and containment remains the main priority, however, urban areas also pose a significant health and safety risk.

Urban areas are likely to feature intricate drainage and sewage systems, therefore important to prevent the spread of oil to these highly sensitive areas where there is a risk of either contamination with sewage treatment plants and/or watercourses by:

- Using dams formed from soil, sandbags, or sorbents to protect inlets.
- Seal drain gratings with plastic bags filled with water and sand.

Oil and the associated fumes can also be highly volatile. As the vapours are heavier than air, it will gather in underground lines, wells, and troughs. This leads to an increased explosion risk; therefore, it is essential to minimize the potential of ignition, ensuring that:

- Traffic is stopped and other ignition sources are extinguished.
- Any affected system operators such as utilities, telephone and railways are informed.

On Static Water

On larger areas of static water, boom can be used to contain the floating oil. The water bodies can be subject to wind-induced wave action, causing the oil to drift, therefore making it necessary to prioritize the containment to prevent further spreading. Where lakes etc. are fed and drained by watercourses, their inlets and outlets need to be protected, methods described in oil on moving water can be utilized.

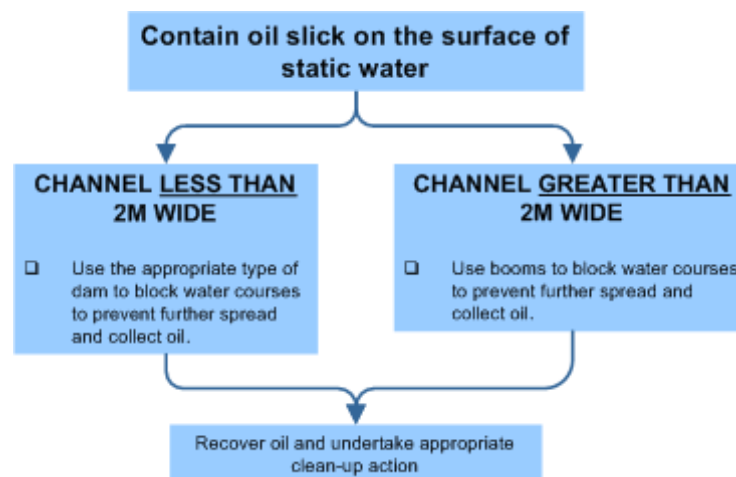

Containment and Recovery, continued

On Moving Water

For spills that occur in rivers with currents more than 0.5 m/s, various techniques, and equipment, including booms and dams, have been developed to suit the relevant environmental conditions. In currents faster than 1 m/s, it is advisable to use techniques that allows water to flow freely subsurface while containing the oil solely on the surface of the water, such as a sorbent fence, inverted weir, culvert block, water gate or turner valley gate.

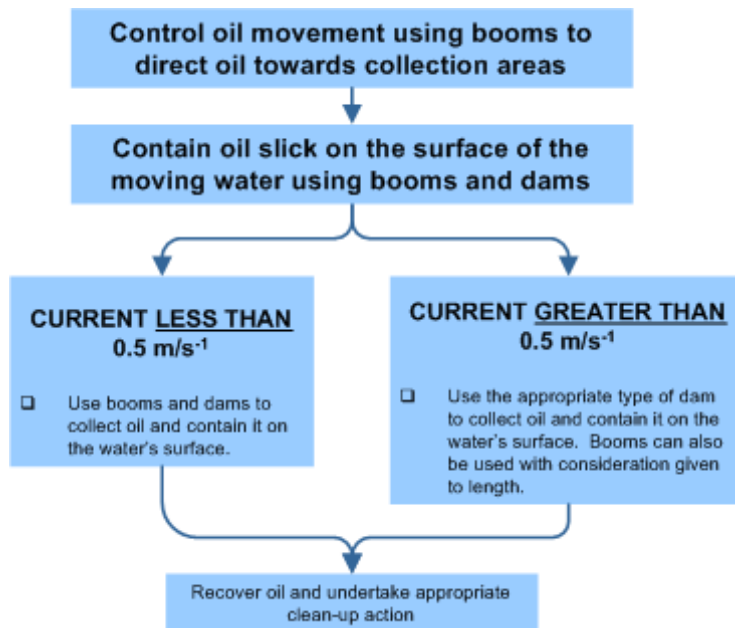



Containment and Recovery, continued

Containment to Recovery Process for Moving Water

Booms can be used to direct the flow of oil, limit any further spread, and then contain it on the water's surface ready for recovery. Different techniques can be employed depending on the quantity of oil spilled and the surrounding operational and environmental conditions, such as the width and windings in the channel of a river, stream, or other watercourse.

If there are pre-determined control point tactical plans this will also guide the location, personnel and equipment required to implement the containment to recovery process.

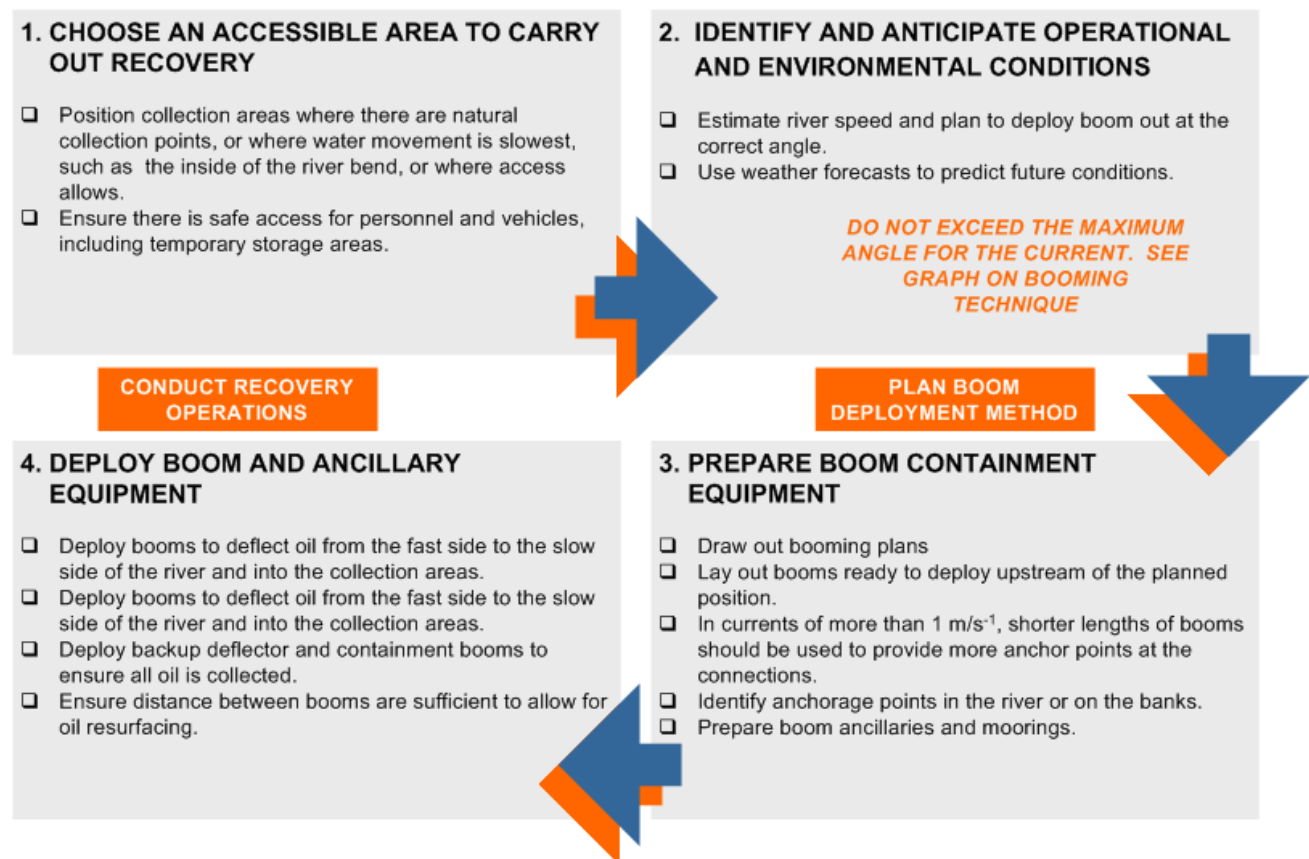



Containment and Recovery, continued

Recovery of Spilled Product

A range of response strategies are available to the responder, dependent on resources accessibility. Each strategy will require a level of expertise, coordination and is likely to generate waste. These factors should also be considered when deciding on the most appropriate clean-up method to use.

Natural Recovery

In some areas, it may be less environmentally damaging to allow the area to recover naturally. Natural recovery is a slow process; however, it may be the only course of action from a safety and operational perspective.



Manual Clean Up

Manual recovery is a labor-intensive strategy that utilizes large numbers of people collecting stranded oil with the necessary tools; shovels, buckets, etc.

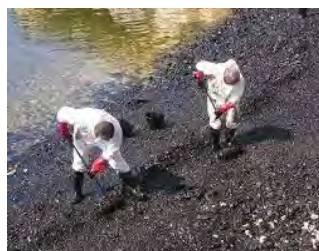

Mechanical Recovery

Oil can be removed from the surface using a multitude of machinery, including pumps and vacuum equipment, scrapers, graders, and oil skimmers.



Use of Water

Flooding can cause the oil to float on the water, this allows it to be recovered later by pumps and skimmers. Flushing can be used to remobilize the oil from the soil and/or wash it from the surface. Both techniques should be used carefully, and containment boom in place to prevent further spread.



Sorbents

Sorbents, made of oleophilic materials; natural (straw) and synthetic (polypropene), can be introduced to the area to selectively absorb the oil while repelling water.



In-Situ Burn

In-situ burning may be considered when physical recovery is not feasible. It is best used in remote areas, especially where roots are protected by high water levels. Some environments may recover from burning more readily than if left oiled without treatment.





Containment and Recovery, continued

Recovery Techniques

Technique	Description	Equipment / Resources	Applicability	Environmental Impacts
Manual Clean Up	Hand tool (scrapers, wire brushes, shovels, cutting tools, wheelbarrows, etc.) are used to scrape oil off surfaces or recover oiled sediments, vegetation, or debris where oil conditions are light or sporadic and/ or access is limited.	<ul style="list-style-type: none"> • Shovels • Buckets • Sorbents • (10-20) labourers 	<ul style="list-style-type: none"> • Can be used on all habitat types • Light to moderate oiling conditions for stranded oil or heavy oils that have formed semi-solid to solid masses • In areas where roosting or birthing animals cannot or should not be disturbed. 	<ul style="list-style-type: none"> • Sediment disturbance and erosion potential.
Mechanical Removal	Mechanical earthmoving equipment is used to remove oiled sediments and debris from heavily impacted areas with suitable access.	<ul style="list-style-type: none"> • Motor grader, • Backhoe • Dump truck • Elevating scrapers • (2-4) labourers • Equipment operators 	<ul style="list-style-type: none"> • On land, wherever surface sediments are accessible to heavy equipment • Large amounts of oiled materials. 	<ul style="list-style-type: none"> • Removes upper 5 to 30 cm of sediments.
Sorbent Use	Sorbents are applied manually to oil accumulations, coatings, sheens, etc. to remove and recover the oil.	<ul style="list-style-type: none"> • Hand tools • Sorbents • (2-10) labourers 	<ul style="list-style-type: none"> • Can be used on all habitat types • Free-floating oil close to shore or stranded on shore, secondary treatment method after gross oil removal • Sensitive areas where access is restricted. 	<ul style="list-style-type: none"> • Sediment disturbance and erosion potential • Trampling of vegetation and organisms • Foot traffic can work oil deeper into soft sediments.
Vacuum / Pumps / Skimmers	Pumps, vacuum trucks, skimmers are used to remove oil accumulations from land or relatively thick floating layers from the water.	<ul style="list-style-type: none"> • (1-2) - 50 to 100 bbl vacuum trucks w/ hoses • (1-2) nozzle screens or skimmer heads • (2-6) labourers • truck operators 	<ul style="list-style-type: none"> • Can be used on all habitat types • Stranded oil on the substrate • Shoreline access points. 	<ul style="list-style-type: none"> • Typically, does not remove all oil • Can remove some surface organisms, sediments, and vegetation.
Flooding	High volumes of water at low pressure are used to flood the oiled area to float oil off and out of sediments and back into the water or to a containment area where it can be recovered. Frequently used with flushing.	<ul style="list-style-type: none"> • (1-5) - 380 to 750 lpm pumping systems • (1) – 100 ft perforated header hose per system • (1-2) – 200 ft containment booms per system • (1) oil recovery device per system • (6-8) labourers per system 	<ul style="list-style-type: none"> • All shoreline types except steep intertidal areas • Heavily oiled areas where the oil is still fluid and adheres loosely to the substrate • Where oil has penetrated gravel sediments • Used with other washing techniques. 	<ul style="list-style-type: none"> • Can impact clean down gradient areas • Can displace some surface organisms if present • Sediments transported into water can affect water quality.



Containment and Recovery, continued

Technique	Description	Equipment / Resources	Applicability	Environmental Impacts
Flushing	Water streams at low to moderate pressure, and possibly elevated temperatures, are used to remove oil from surface or near-surface sediments through agitation and direct contact. Oil is flushed back into the water or a collection point for subsequent recovery. May also be used to flush out oil trapped by shoreline or aquatic vegetation.	<ul style="list-style-type: none"> • (1-5) - 189 to 380 lpm / 689 kpa pumping systems with manifold • (1-4) - 30 m hoses and nozzles per system • (1-2) - 60 m containment booms per system • (1) oil recovery device per system • (8-10) labourers per system 	<ul style="list-style-type: none"> • Substrates, riprap, and solid man-made structures • Oil stranded onshore • Floating oil in shallow areas. 	<ul style="list-style-type: none"> • Can impact clean down gradient areas • Will displace many surface organisms if present • Sediments transported into water can affect water quality • Hot water can be lethal to many organisms • Can increase oil penetration depth.
High Pressure Washing	High pressure water streams are used to remove oil coatings from hard surfaces in small areas where flushing is ineffective. Oil is directed back into water or collection point for subsequent recovery.	<ul style="list-style-type: none"> • (1-5) - 1,200 to 4,000 psi units with hose and spray wand • (1-2) - 30 m containment booms per unit • (1) oil recovery device per unit • (2-4) labourers per unit 	<ul style="list-style-type: none"> • Bedrock, man-made structures, and gravel substrates • When low-pressure flushing is not effective • Directed water jet can remove oil from hard-to-reach sites. 	<ul style="list-style-type: none"> • Will remove most organisms if present • Can damage surface being cleaned • Can affect clean down gradient or nearby areas.
Sediment Tilling	Mechanical equipment or hand tools are used to till lightly to moderately oiled surface sediments to maximize natural degradation processes.	<ul style="list-style-type: none"> • (1) tractor fitted with tines, dicer, ripper blades, etc., or • (1-4) rototillers • hand tools • (2-10) labourers 	<ul style="list-style-type: none"> • Any sedimentary substrate that can support heavy equipment • Sand and gravel beaches with subsurface oil • Where sediment is stained or lightly oiled • Where oil is stranded above normal high waterline. 	<ul style="list-style-type: none"> • Significant amounts of oil can remain on the shoreline for extended periods of time • Disturbs surface sediments and organisms.
Log / Debris Burning	Oiled logs, driftwood, vegetation, and debris are burned to minimize material handling and disposal requirements. Material should be stacked in tall piles and fans used to ensure a hot, clean burn.	<ul style="list-style-type: none"> • (1) set of fire control equipment • (2-4) fans • (1) supply of combustion promoter • (2-4) labourers 	<ul style="list-style-type: none"> • On most habitats except dry muddy substrates where heat may impact the biological productivity of the habitat • Where heavily oiled items are difficult or impossible to move • Many potential applications on ice. 	<ul style="list-style-type: none"> • Heat may impact local near-surface organisms • Substantial smoke may be generated • Heat may impact adjacent vegetation.
Natural Recovery	No action is taken, and oil is allowed to degrade naturally	<ul style="list-style-type: none"> • None required 	<ul style="list-style-type: none"> • All habitat types • When natural removal rates are fast • Oiling is light • Access is severely restricted or dangerous to cleanup crews • When cleanup actions will do more harm than natural removal. 	<ul style="list-style-type: none"> • Oil may persist for significant periods of time • Remobilized oil or sheens may impact other areas • Higher probability of impacting wildlife.

SORBENTS



Sorbents can be used to recover oil product that can not be easily recovered using mechanical methods. They are predominately single-use products. When allowed to come in contact with oil on water, they will absorb or adsorb the oil over time.

Objectives

- ◇ Prevent further migration of released products.
- ◇ Recover released product in areas that it may be difficult to reach.



Safety

- ◇ Identify hazards and complete a site safety plan.
- ◇ Consider toxic and flammable vapours.
- ◇ Adjacent infrastructure such as powerlines, pipelines, and underground services.
- ◇ Waders, safety harness, line and PFD may be required.



Environmental Consideration

- ◇ Utilize existing access and routes to minimize disturbance of soils. Consider environmental sensitivities such as vegetation soil types and wildlife/fish habitat.
- ◇ Ensure decontamination areas have been established to minimize transfer of released product during site assessment and site preparation activities.
- ◇ Consider air quality issues and proximity of stakeholders.



Equipment / Resources

- ◇ Sorbents
- ◇ Waste disposal bags
- ◇ Gloves



Personnel

- ◇ Supervisor / lead
- ◇ Site safety
- ◇ Labourers



Procedure

- ◇ Use sorbents to soak up and recover released product.
- ◇ Place used sorbents in waste bags for off-site disposal.



SORBENT PADS

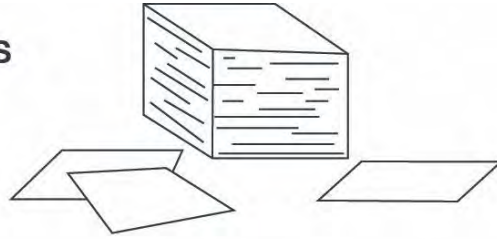

Sorbent Pads

- ◇ Generally smaller in size. Useful for spot cleaning by hand.

Sorbent Booms

- ◇ Sorbent booms are easily deployed in low current environments.
- ◇ Usually sausage-shaped, with a few inches of height above the water when floating.



SORBENT BOOMS

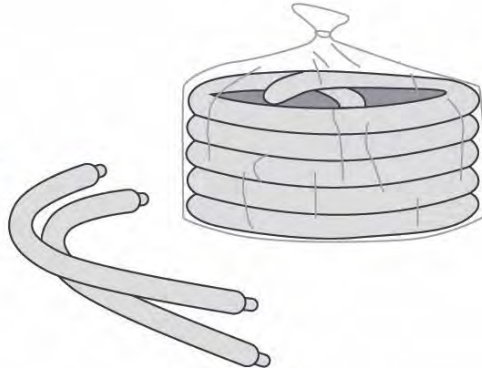

Sorbent Sweeps

- ◇ Long, narrow sheets of sorbent material with an integral tension member.
- ◇ Sorbent sweeps can be used in place of sorbent booms for managing and recovering sheens.

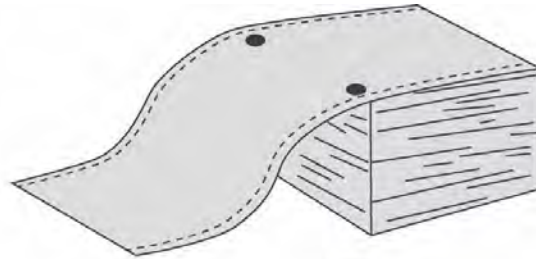

SORBENT SWEEPS

Sorbent Socks

- ◇ A smaller, more compact version of sorbent booms.
- ◇ Useful for building small containment walls around storm drains, sumps, bilges or sewer entries.

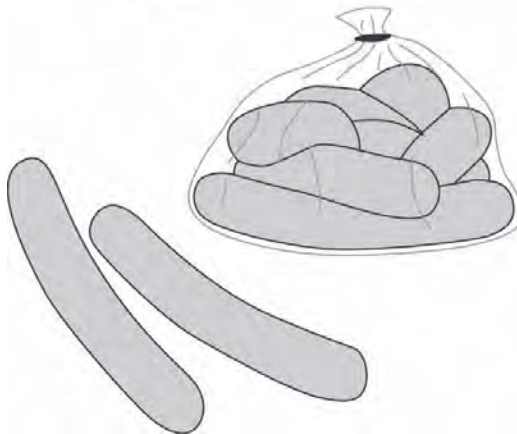

SORBENT SOCKS



BERMS



Berms can be constructed using any non-porous material using mechanical or hand equipment. They can be used to prevent migration of released product as well as used to divert surface flow from areas that have been impacted by a spill. They are used in conjunction with other containment and recovery methods such as trenches, bell holes and inverted weirs.

Objectives

- ◇ To halt the advance of spilled product and allow for the recovery of the spilled product.
- ◇ Contain and prevent further migration of released products by channeling the spill in a particular direction
- ◇ Create a pooled area for recovery of released product.
- ◇ Diversion of surface flows from impacted area.



Safety

- ◇ Identify hazards and complete a site safety plan.
- ◇ Consider toxic and flammable vapours.
- ◇ Adjacent infrastructure such as powerlines, pipelines, and underground services.
- ◇ Establish communications in remote areas.
- ◇ Be cautious of wildlife.



Environmental Consideration

- ◇ Utilize existing access and routes to minimize disturbance of soils. Consider environmental sensitivities such as vegetation soil types and wildlife/fish habitat.
- ◇ If possible, remove and conserve topsoil for reclamation activities. Avoid constructing berms with topsoil material.
- ◇ Ensure decontamination areas have been established to minimize transfer of released product during construction of berm.
- ◇ Handle and dispose of contaminated wastes in an approved manner.



Equipment / Resources

- ◇ Shovels and/or earth moving equipment
- ◇ Plastic sheeting
- ◇ Sorbents
- ◇ Vacuum truck / portable vacuum unit



Personnel

- ◇ Supervisor / lead
- ◇ Site safety
- ◇ Labourers
- ◇ Vacuum truck operator



Procedure

- ◇ Lay plastic on ground, across expected route of spill travel.
- ◇ Pile non-porous materials on downstream side of plastic (away from approaching oil).
- ◇ Flip upstream side of plastic sheet over berm to prevent contamination of berm contents.
- ◇ Hand dig small bell hole upstream of berm recovery.
- ◇ Ensure waste disposal bags and tags if sorbents are to be used.

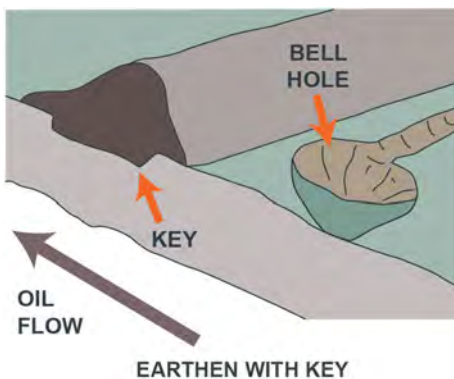

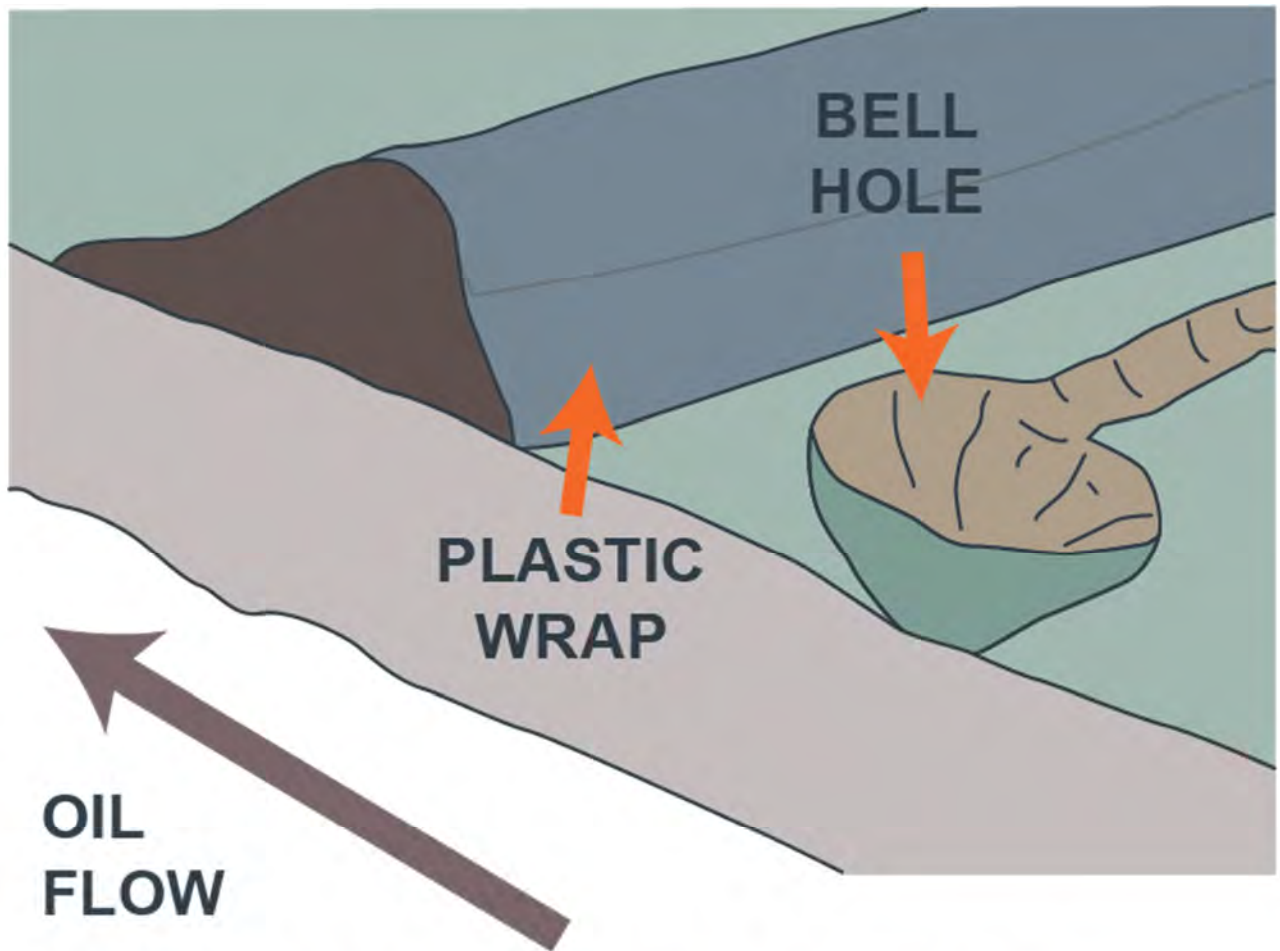

EARTHEN PLASTIC WRAP



SURFACE FLOW DIVERSION

TRENCHES AND BELL HOLES



Trenches can be excavated to contain a spill and used most commonly with bell holes to allow recovery of fluids and released product via vacuum unit or transfer pumps. For additional containment, the materials excavated from the trench can be used to construct berms downgradient of the trench. For larger spills, skimmers can be considered for recovery of released products.

Objectives

- ◇ To halt the advance of the spilled product and allow for recovery while reducing potential for environmental damage.
- ◇ Provide capacity to recover released product and ensure containment.
- ◇ To stop spilled product where a significant containment capacity is required on a slope.



Safety

- ◇ Identify hazards and complete a site safety plan.
- ◇ Consider toxic and flammable vapours.
- ◇ Adjacent infrastructure such as powerlines, pipelines, and underground services.
- ◇ Consider ground disturbance requirements.



Environmental Consideration

- ◇ Utilize existing access and routes to minimize disturbance of soils. Consider environmental sensitivities such as vegetation soil types and wildlife/fish habitat.
- ◇ Utilize low lying areas to minimize depth of excavations.
- ◇ Keep trench depth at a minimum to prevent further sub-surface or groundwater impacts.
- ◇ Stockpile clean materials for reclaiming area of trenches and bell holes.
- ◇ Ensure decontamination areas have been established to minimize transfer of released product during construction of trenches and bell holes.



Equipment / Resources

- ◇ Shovels / earth moving equipment
- ◇ Plastic sheeting
- ◇ Vacuum truck / vacuum unit
- ◇ Transfer pump / skimmer
- ◇ Temporary storage
- ◇ Containment booms
- ◇ Sorbents
- ◇ Hand lines



Procedure

- ◇ Excavate shallow trench downstream and ensure berm is on downstream side of trench. Line the trench and berm with plastic sheeting to prevent contamination of berm contents.
- ◇ Excavate bell hole at low end of trench for the collection of fluids.
- ◇ Recover collected fluids using vacuum truck / vacuum unit or transfer pump into temporary storage.



Personnel

- ◇ Supervisor / Lead
- ◇ Site Safety
- ◇ Labourers
- ◇ Vacuum truck operator



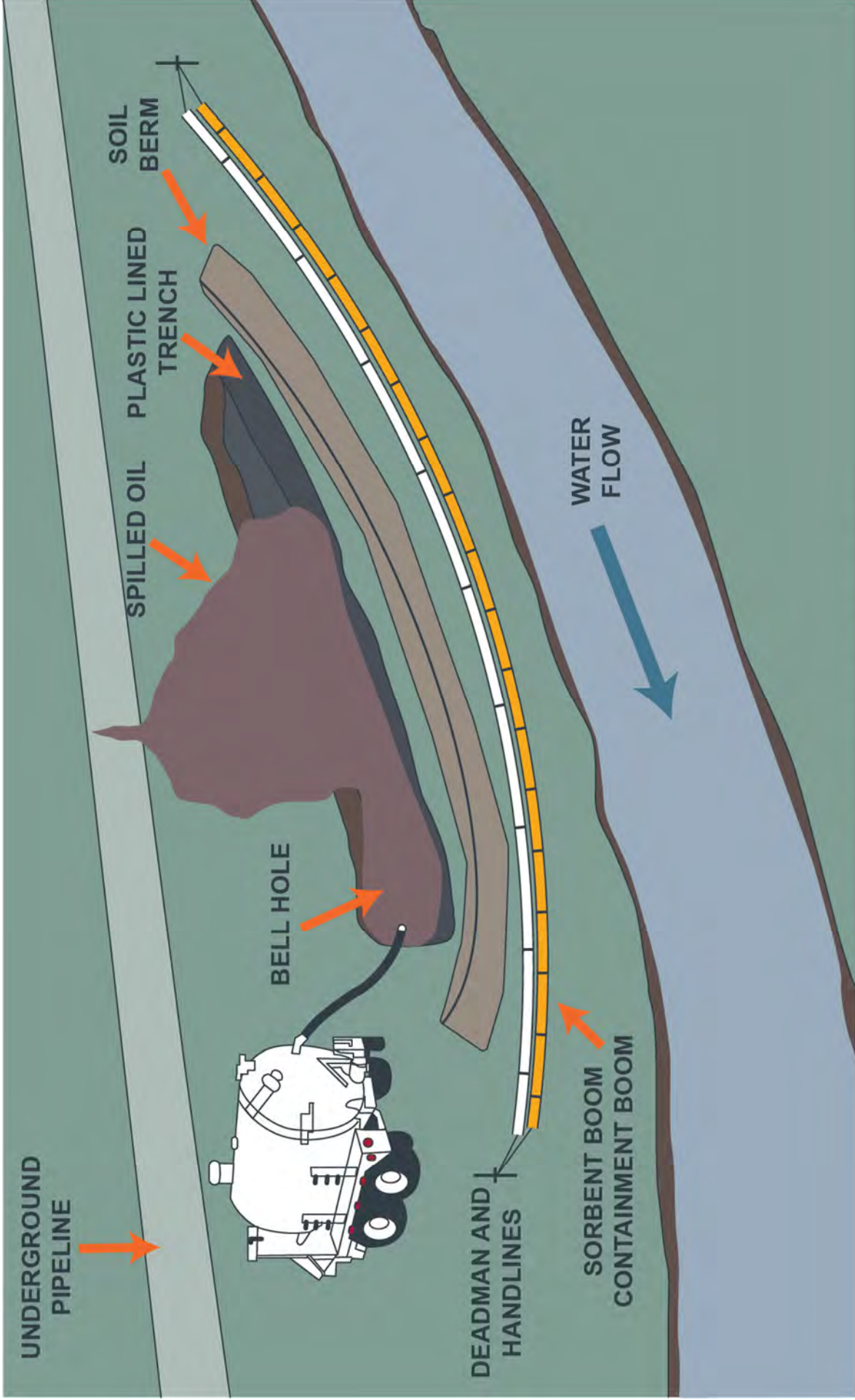

TRENCH AND BELL HOLE

AQUADAM



Aquadam's are made up of multiple parallel chambers called fill tubes which give it a level of stability against shifting. While slightly more complicated to place and fill than a simple bladder, in many cases it does not require external anchors. Use in slow moving shallow watercourses.

Objectives

- ◇ Contain and facilitate recovery of a water-borne spill from a ditch, creek or stream.
- ◇ Contain and prevent further migration of released products.
- ◇ Provide capacity to recover released product and impacted fluids.



Safety

- ◇ Identify hazards and complete site safety plan.
- ◇ Consider toxic and flammable vapours.
- ◇ Adjacent infrastructure such as powerlines, pipelines, and underground services.
- ◇ Establish communications in remote areas.
- ◇ Be cautious of wildlife.



Environmental Consideration

- ◇ Maintain control of damming materials to avoid introducing foreign substances into the watercourse.
- ◇ Utilize existing access routes to minimize disturbance of soils and care should be taken to minimize disturbance of watercourse and banks. Consider environmental sensitivities such as vegetation soil types and wildlife/fish habitat.
- ◇ Ensure decontamination areas have been established to minimize transfer of released product during setup.
- ◇ Handle and dispose of contaminated wastes in an approved manner.



Equipment / Resources

- ◇ Aquadam / water bags
- ◇ Water source
- ◇ Trash pump / hose
- ◇ Suction hose
- ◇ Vacuum unit
- ◇ Skimmer



Personnel

- ◇ Supervisor / lead
- ◇ Site Safety
- ◇ Labourers
- ◇ Vacuum truck operator



Procedure

- ◇ Set up trash pump/hose.
- ◇ Prepare area by removing any sharp debris that could puncture or damage the aquadam.
- ◇ Unroll aquadam across the area of desired containment.
- ◇ Fill aquadam using trash pump and hose.
- ◇ Recover released product using skimmer / vac unit.



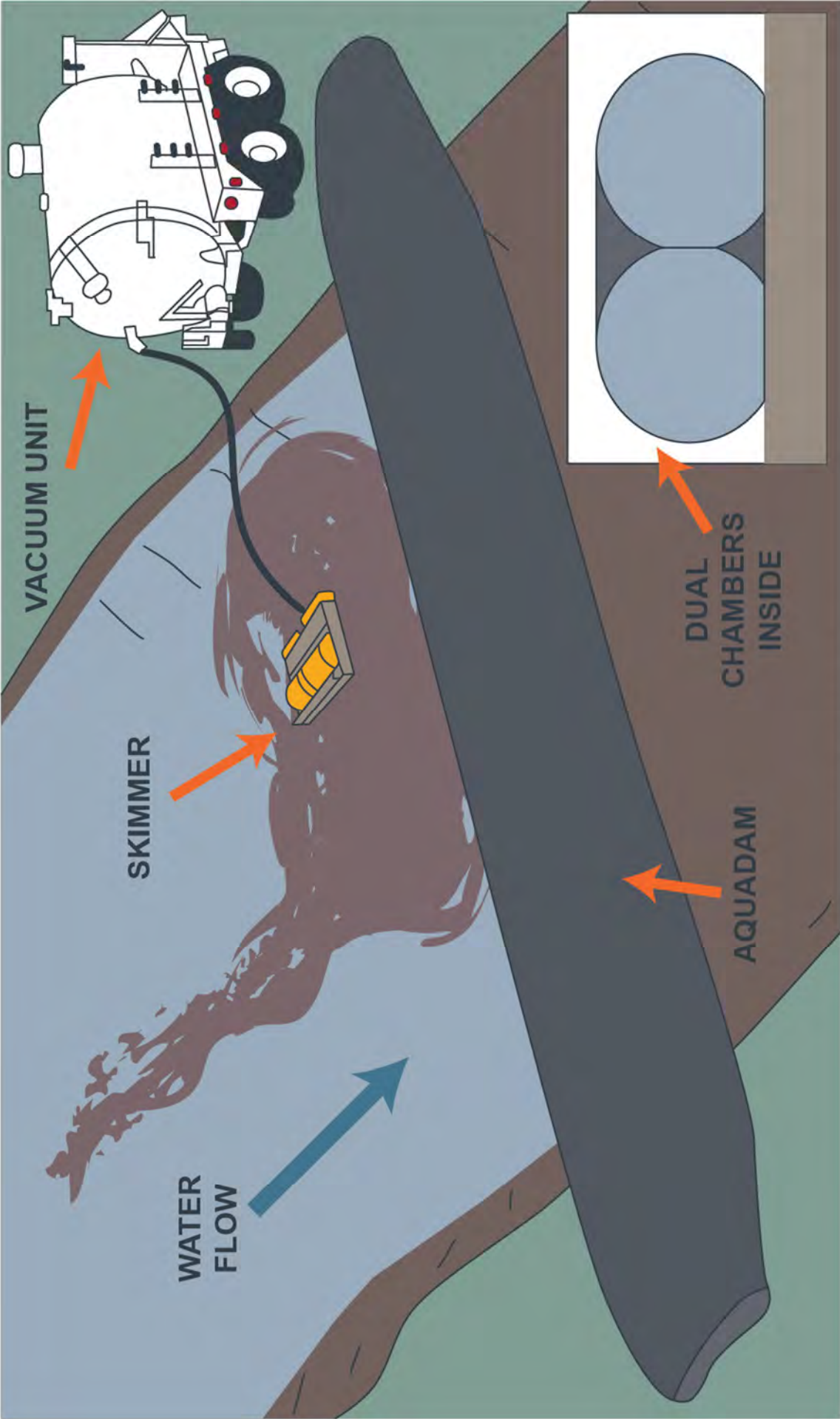

AQUADAM

CULVERT BLOCK



Culverts that allow a watercourse to pass under or through obstacles present an opportunity for controlling the spread of oil. If water flows are sufficiently low, they can be blocked entirely with boards or plywood to contain oil above the culvert. In higher flow situations, partial culvert blocks can be installed to create underflow dams.

Objectives

- ◇ Contain and prevent further migration of released products using sandbags / plywood.
- ◇ Create pooled area to allow recover of released product.



Safety

- ◇ Identify hazards and complete a site safety plan.
- ◇ Consider toxic and flammable vapours.
- ◇ Adjacent infrastructure such as powerlines, pipelines, and underground services.
- ◇ Establish communications in remote areas.



Environmental Consideration

- ◇ Utilize existing access and routes to minimize disturbance of soils. Consider environmental sensitivities such as vegetation soil types and wildlife/fish habitat.
- ◇ Ensure decontamination areas have been established to minimize transfer of released product during site assessment and site preparation activities.
- ◇ Consider air quality issues and proximity of stakeholders.
- ◇ Manage board level to allow water to pass through culvert, reducing flooding upstream and maintain downstream flow.



Equipment / Resources

- ◇ Track hoe
- ◇ Sorbents
- ◇ Shovels
- ◇ Earthen materials or sandbags
- ◇ Vacuum truck / portable vacuum unit
- ◇ Skimmer
- ◇ Temporary storage
- ◇ Plywood, stakes, nails



Procedure

- ◇ Using earthen materials or sandbags, completely block the culvert or,
- ◇ Using plywood on upstream side of culvert. Secure in place with two stakes driven into bed of ditch, creek or stream. Raise board enough to allow passage of water under the board's lower edge. Secure in place with driving nails through stakes into the plywood.
- ◇ Monitor water levels to ensure sufficient flow and to prevent washouts.
- ◇ Utilize vacuum unit or skimmer to recover pooled fluids and dispose at appropriate location.
- ◇ Utilize containment boom to protect banks from oil impacts.



Personnel

- ◇ Track hoe operator
- ◇ Vacuum operator
- ◇ Supervisor / lead
- ◇ Site safety
- ◇ Labourers



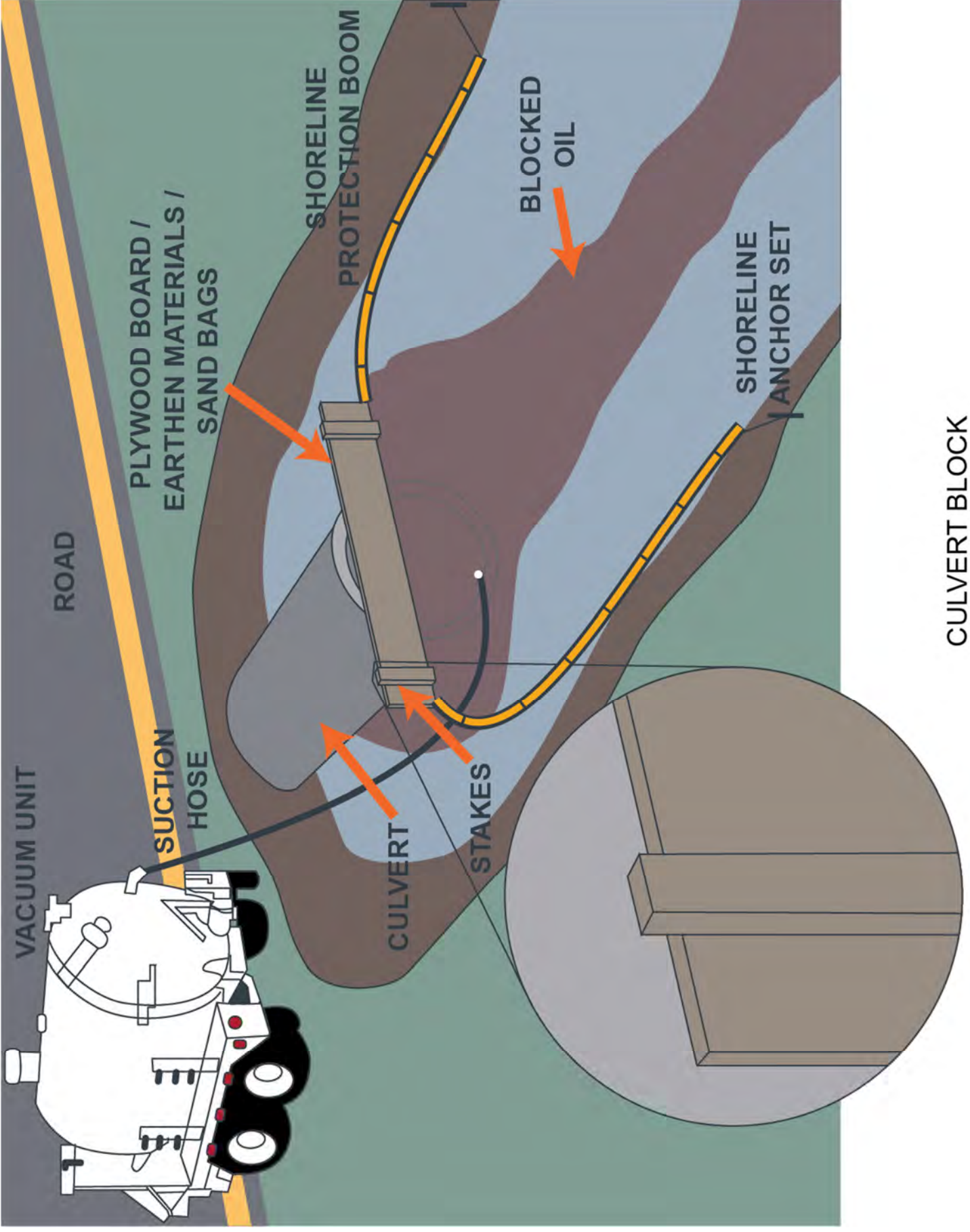

CULVERT BLOCK

BOOM DEPLOYMENT



Larger watercourses are those where any combination of water depth, river or stream width, or current velocity would make the installation of bottom-founded or rigid fixtures impractical. The tactics that follow rely on the installation of flexible, floating barriers to redirect or divert surface contaminants.

Objectives

- ◇ Divert surface contaminants from sensitive resources.
- ◇ Divert surface contaminants to areas of quiet water where velocities are slower and contaminants may be collected.



Floating Containment Boom

- ◇ Identified by the overall height of the boom or by the diameter of the float and the depth of the skirt.
- ◇ Shallow skirts are advised for fast moving waters, because their reduced drag makes them easier to deploy and secure. Deeper skirts are advised where waves may be encountered.

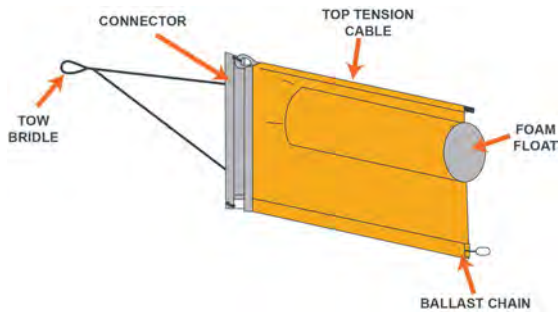

Boom Property	Static Water	Moving Water
Overall height (in)	6 - 24	8 - 32
Minimum gross buoyancy to weight ratio	3:1	4:1
Minimum total tensile strength (lbs)	1,500	5,000

75°	60°	45°	30°	15°
1.4 kph	1.6 kph	2.0 kph	2.8 kph	5.4 kph
0.9 mph	1.0 mph	1.2 mph	1.7 mph	3.3 mph

Shore Seal Boom

- ◇ Provides an effective barrier to control the spread of oil in the critical region where water meets the shoreline.
- ◇ A floating barrier with integral water bags that provide an effective seal when grounded.
- ◇ A smaller tube is fitted into a larger tube. The larger outer tube is filled with water and the smaller inner tube is filled with air.
- ◇ Shore seal boom can adjust to fluctuating water levels.

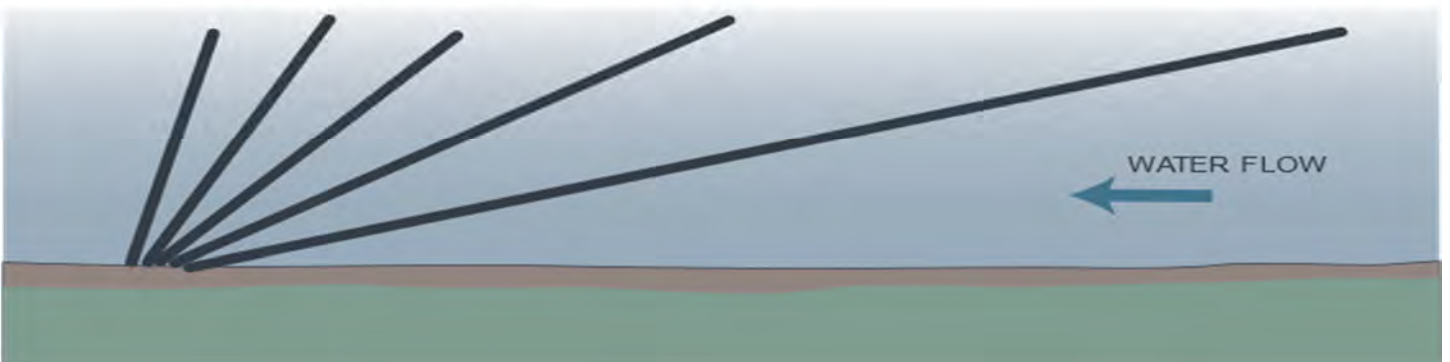
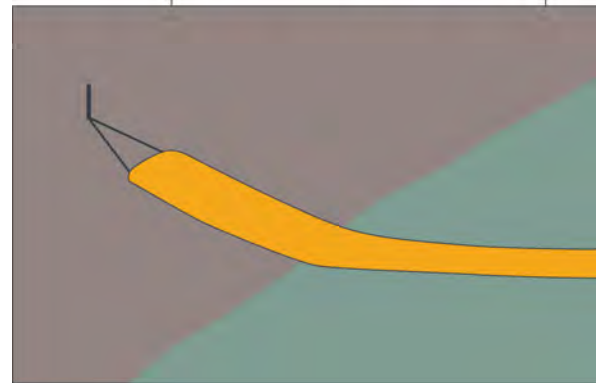
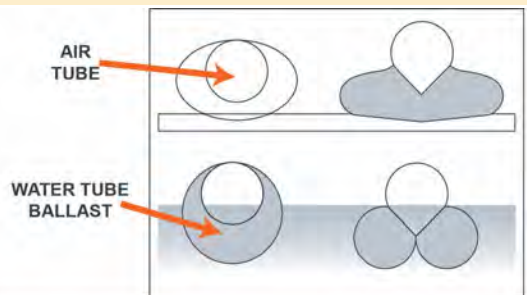

Time in seconds stick travels 30 m (100 ft)	Current km/hr	Current mph	Current (metres per second)	Current (feet per second)	Boom angle (degrees to current)
216 108 72 54	0.5 1.0 1.5 2.0	0.31 0.62 0.93 1.25	0.14 0.28 0.42 0.56	0.46 0.92 1.38 1.84	30 degrees
43 36 31 27	2.5 3.0 3.5 4.0	1.5 1.9 2.2 2.5	0.69 0.83 0.97 1.11	2.26 2.72 3.18 3.60	20 degrees
24 22 18	4.5 5.0 6.0	2.8 3.1 3.7	1.25 1.39 1.67	4.10 4.56 5.48	15 degrees
15 14 12 11	7.0 8.0 9.0 10.0	4.3 5.0 5.6 6.2	1.94 2.22 2.50 2.78	6.36 7.28 8.20 9.12	10 degrees

Considerations

When determining the type of containment operation to be utilized on a watercourse, the following should be considered:

- ◇ The slower the current and deeper the water, the more effective the containment and recovery operations will be.
- ◇ Chose a location where the current is directed towards the recovery area.
- ◇ Consider access and staging when selecting a recovery location.
- ◇ On larger watercourses chose a location that is on the side as the spill.
- ◇ Boom should be a straight as possible to defect oil to recovery areas.
- ◇ Boom angle is critical for ongoing maintenance of containment and recovery operations.
- ◇ In faster moving water, consider additional containment boom downstream to capture any flow through.
- ◇ If not feasible to boom entire channel, select as site that will capture most of the released product and consider further downstream containment and recovery areas.
- ◇ Select boom anchoring methods considering the following:
 - ◇ Shoreline Pins can be used on narrow slow-moving watercourses and installed along the banks and include drive pin, screw, wing pin anchors, trees, or large rocks.
 - ◇ Trolley Line can be deployed across large, moderate to fast moving watercourses and can be used with split pulley to deploy and adjust the boom angle.
 - ◇ Bridge Pier Bridle can be installed on large, moderate to fast moving watercourse with the use of workboats
 - ◇ In-Stream anchors and chain sets can be deployed within the watercourse by workboat crews and include sarca, danforth and rake anchors.
 - ◇ Boom Vane can be deployed from shore and utilizes the instream current and mooring lines to set boom angles.



SKIMMERS, VACUUM UNITS, TEMPORARY STORAGE



Recovery will involve the use of equipment as determined by plans and the scope of the incident.

Skimmers

- ◇ Selective skimmers rely on oleophilic material that can be passed through the oil-interface. Selective skimmers collect a higher concentration of oil in the recovered fluid stream than non-selective skimmers.
- ◇ Non-selective skimmers are usually weir or suction devices that recover fluid indiscriminately.

Skimmer Type	Oil Type	Mode	Debris Tolerance	Wave Tolerance	Currents
Drum (selective)	Wide range of oil viscosities	Stationary	Debris must be managed to allow flow of oil to skimmer	Low sensitivity to waves with height less than diameter of drum	Not generally used in currents
Disc (selective)	Low to medium viscosity	Stationary	Debris must be managed to allow flow of oil to skimmer	Low sensitivity to waves with height less than diameter of disc	Not generally used in currents
Brush (selective)	Medium to high viscosity	May be operated in stationary mode if current is present	Effective in most forms of small debris	Low sensitivity to waves	May be operated in stationary mode if current is present
Pedco (non-selective)	Wide range of oil viscosities	Stationary	Debris must be managed to allow flow of oil to skimmer	Low sensitivity to waves	Used in currents typically river, streams and creeks
Circus (non-selective)	Wide range of oil viscosities	Stationary and advancing	Debris must be managed to allow flow of oil to skimmer	Good wave-following characteristics in nonbreaking waves	Used in currents typically river, streams and creeks
Broad Suction (non-selective)	Wide range of oil viscosities	Powered by vacuum or pump	Works around debris	Low sensitivity to waves	Static water conditions

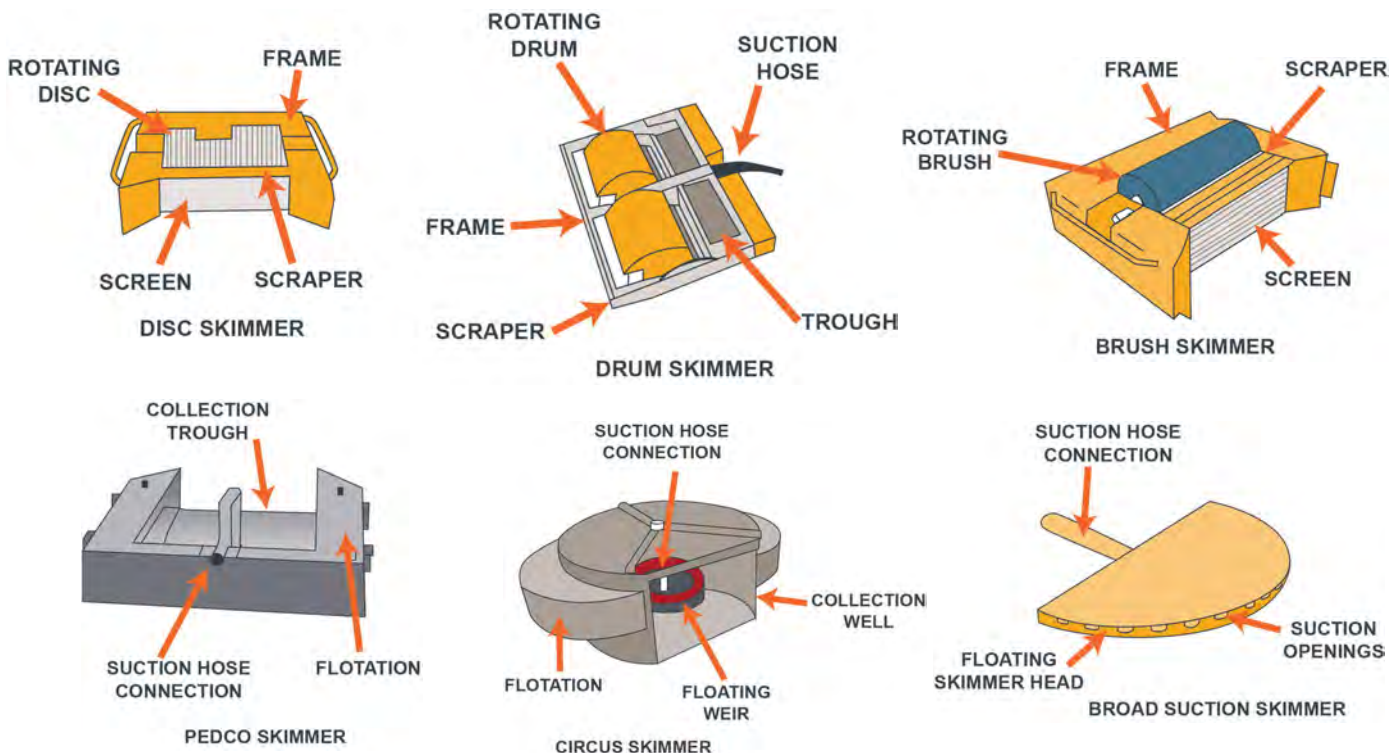

Vacuum Units

- ◇ Operate on the same principle as an industrial vacuum cleaner
- ◇ A suction pump pulls large quantities of air through a hose and into a large-volume receptacle. The sudden velocity drop that occurs in the receptacle causes liquids and solids to fall out of the airstream and collect. This process may be aided by internal baffles in the receptacle.
- ◇ May be used in place of pumps to operate pedco or broad suction skimmers or to transfer collected oil from disc or drum skimmers.

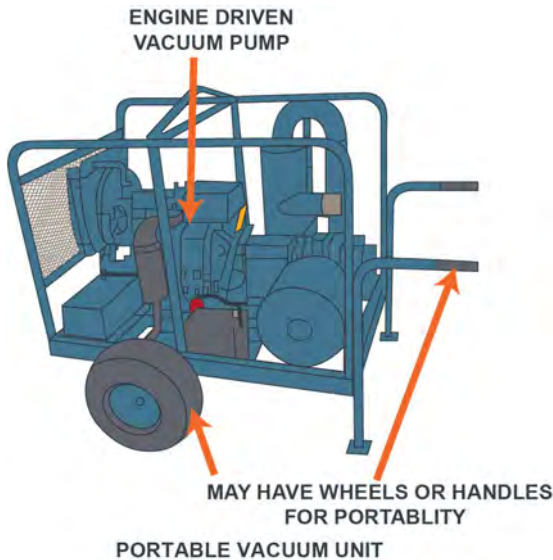

Temporary Storage

- ◇ Recovered oil can be critical to the success of a spill response. Temporary storage tanks are usually fabric, for storage and portability.
- ◇ Depending on the type, they may or may not have a rigid frame
- ◇ Note that open storage devices do not have positive vapour control. Hence, they may not be suitable for storage of highly volatile products.

Storage Type	Vapour Control	Capacity	Storage Length
Pillow Tank	Yes	750 - 19,000 L	Temporary and long-term
Open Storage - Rigid Frame	No	900 - 75,000 L	Temporary
Open Storage - Frameless	No	750 - 19,000 L	Temporary

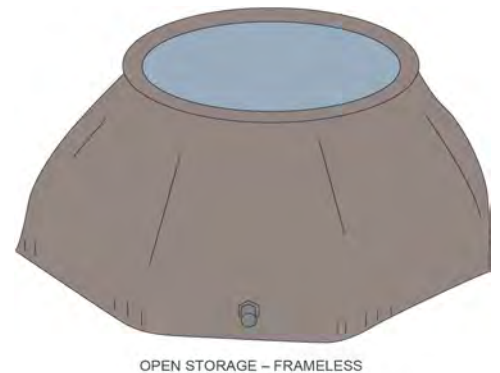
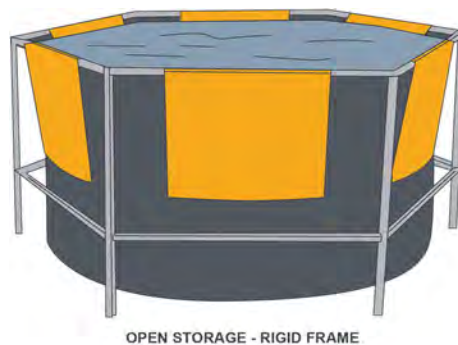
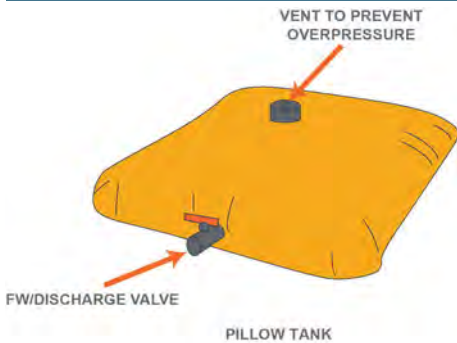



Post-Incident

Ensure all statements, event logs, forms and documentation on the incident remain securely stored following the incident. Records must be held for a minimum of 5 years as it may be requested by the regulatory agency at any point during that time.

Call Down Notification

After consultation with a senior company representative or the appropriate Regulatory Agency, Provincial Emergency Management or local County / Municipality, the Incident Commander will:

1. Give the "all clear" signal. Prior to the "all-clear" signal, the Incident Commander will confirm that all evacuated areas are safe to re-enter. This may involve such activities as:
 - o Ensuring all equipment and locations are free of any pockets of fire, smoke and / or toxic gases.
 - o Ensuring all equipment and debris are removed from offices and / or public areas.
 - o Cordoning off the incident area to isolate any remaining hazards.
 - o Checking low-lying areas and basements for contamination, if a toxic leak has occurred.

After the "all-clear" message has been given, the Incident Commander will be responsible for:

- o Ensuring all evacuees are promptly notified once the call down is given.
 - o Coordinating the return of any evacuees to the area. Ensure the public and employees receive any assistance they may require.
 - o Maintaining security in any evacuated areas until the evacuees have returned and the businesses in the area have again become occupied.
2. Coordinate the deactivation of all emergency response operations, personnel, equipment and incident areas.
 3. Ensure all previous contacts, including other companies; government agencies, etc. are notified of the emergency status call down.
 4. Advise all response team members to document their call down notification calls.
 5. Prepare and release an "all clear" statement to the media in conjunction with the Regulatory Agency.
 6. Organize debriefing meetings for advisory personnel involved. In the case of incidents that have involved a death or serious injury, consult with Human Resources personnel about arranging critical incident counselling.
 7. Notify and debrief Joint Interest Partners and Insurance company representatives.

Note: Ensure all statements, event logs, forms and documentation on the incident remain securely stored following the incident.

Public Care and Assistance

The decision to recall evacuees will be coordinated by the regulatory agency in consultation with other applicable government agencies and the licensee. Ensure the following tasks are completed as required:

1. Ensure all evacuees are promptly notified once the call down is given.
2. Coordinate the return of any evacuees to the area. Ensure the public and employees receive any assistance they may require.
3. Maintain security in any evacuated areas until the evacuees have returned and the businesses in the area have again become occupied.
4. Ensure homes and businesses are ventilated and checked for gas pockets before allowing the occupants to enter. Rovers must check each room, office and public area.



Post-Incident, continued

5. Ensure members of the Response Teams and other key participants in the emergency are debriefed as soon as possible.
6. Designate a senior company representative to act as the company Liaison with the public and other companies.
7. Ensure the affected employees and public are provided with post-incident company contact names and telephone numbers. If the emergency has impacted a large number of the public or has caused significant damage to private property or the environment, a temporary Public Relations Office should be established in the affected area.
8. Schedule a follow-up meeting with the public to clearly explain the cause of the incident and to address their concerns. Organize critical incident counselling as required.
9. Ensure public expense / damage claims have been collected and are processed in a timely manner.

Clean-up and Repair

If a serious injury or death has occurred, the scene must be left undisturbed, as much as possible, until an investigation of the site can be completed by the appropriate authorities.

Ensure the following tasks are completed as required:

- Ensure the incident site is not disturbed if there has been a fatality or a serious injury until police, regulatory officials and company representatives complete necessary investigations.
- Ensure that site clean-up continues.
- Ensure that the correct procedures are developed and implemented for the decontamination of equipment.
- Ensure the On-Site Group Supervisor disposes of all hazardous waste according to applicable regulations (confer with the safety support personnel, the Response Team or other company safety personnel).

Note: The position of On-Site Group Supervisor during the remediation phase may be best filled by an Environmental Specialist.

- Ensure that priority is given to clearing debris and restoring the site to normal operating conditions after the government and company investigations are complete.
- Ensure that all safety equipment is demobilized, cleaned and inspected for contamination.
- Ensure all roadblocks, staging area and detour equipment is demobilized.
- Ensure that all clean-up and repair actions follow the companies safety and environment policies and safe-work procedures.

Third Party Investigations

The Incident Commander will coordinate and observe all site investigations. Third party investigators such as police, government agencies and insurance companies may be required to investigate an incident site. It is important to co-operate with third party investigators. However, company personnel should be aware of the corresponding corporate guidelines.

- Obtain the name, title, address and telephone number of all inspectors and immediately inform the Incident Commander before proceeding with the investigation.



Post-Incident, continued

- Ensure a company representative accompanies the inspector at all times. Never leave an inspector unattended.
- Give the inspectors the information they request, the facts only, no speculative information. Always tell the truth.

Document all items of evidence that the inspector has retained. Where possible, keep copies of the evidence provided to the Inspectors.

Wait until legal counsel is present before answering questions where the inspector indicates that any statements may be used as evidence or indicates that you have the right to counsel.

Review and Debriefing

The effectiveness of the ERP shall be reviewed after the end of the emergency. In some situations, a formal debriefing may be held. The objective of the debriefing should be to improve emergency preparedness and response by identifying areas of success and areas requiring improvement (a debriefing should not be a fault-finding mission). If one is held, all groups that responded to the emergency should be represented. The representatives should come prepared with complete details of their activities during the emergency and, where possible, provide supporting documentation. Common elements of an effective debriefing include:

- a) A facilitator;
- b) A secretary to record the proceedings;
- c) A review of the sequence of events, including timing and actions taken; and
- d) Identification of those portions of the ERP that were effective and those that require improvement.

Action items identified during the debriefing should be documented and assigned with completion timelines, key lessons learned from emergency outcome should be shared with the appropriate parties, and the ERP should be revised as necessary. Separate debriefings may be held with different groups that participated in the emergency (e.g., emergency services organizations, the media, etc.).

Critical Incident Stress Debriefing (CISD)

Responders are often under a great deal of stress. They must act quickly, often in the face of pain and fear, to assess the situation, determine priorities and begin rescuing others who are in danger. They may have experienced a serious injury themselves or witnessed the death of co-workers or the public.

If necessary, the Incident Commander will request that the company's Human Resource personnel dispatch specially trained counselors to meet with responders, preferably within 24 to 48 hours, to provide support and reassurance to those affected by an emergency. Team members should include a mental health professional and trained peer support personnel (fire-fighters, paramedics, police, military, etc.).

CISDs allow individuals to express the circumstances they were confronted with, how they felt at the incident and what their reactions were after the incident. The participants must understand that the meetings are strictly confidential and are not intended to judge or lay blame on an individual's actions. Recording devices and note taking should be prohibited. Meetings should be limited to a maximum of 20 individuals. Individuals who are perceived to be responsible for the incident should be excluded from group meetings and met on a one-on-one basis.

These sessions provide the responders with a supportive environment that helps them deal with their emotions. It also provides them with information about stress and its effects (severe agitation, emotional upset, inability to sleep, etc.) and it educates them about stress management techniques.



Post-Incident, continued

Post-Incident / Accident Investigation

Once the emergency status has been removed, a senior company representative will appoint a subcommittee to investigate the event. This subcommittee will consist of appropriate management and technical specialists as required.

The objective of the investigation will be to analyze and evaluate the event in order to establish a cause, to provide advice on how to prevent a reoccurrence of the event, and to make recommendations on procedures that will improve the company's emergency response efforts in the future.

The post-incident / accident investigation should include:

- A review of the events leading up to the incident / accident.
- An analysis of the on-site remedial procedures, including an evaluation of the safety standards that were applied.
- An appraisal of the company's shelter-in-place / evacuation response for the affected public.
- An evaluation of the effectiveness of the notification and communication systems between the incident site and the head office, as well as within the company.
- An appraisal of the effectiveness of any media or public relations efforts.
- An assessment of any potential legal or environmental issues that may be raised as a result of the event or as a result of the company's response efforts.
- A summary of current and future costs.
- Completed appropriate event report forms and applicable attachments.
- An assessment of the strengths and weaknesses of the company's response.

This report will be directed to the attention of a senior company representative. It will be his / her responsibility to ensure all recommendations for improvements to the Corporate and Field Emergency Response Plans are incorporated where applicable and promptly communicated to the appropriate company personnel.

All documentation recorded during and following an emergency must be retained for up to five years in the event the Regulatory Agency requests it.



Medical Emergencies

DISCLAIMER: The information contained in this section does not replace formal First Aid, CPR & AED training. The company makes no guarantee as to, and assumes no responsibility for, the correctness, sufficiency or completeness of such information or recommendations. A First Aid provider is someone who has completed formal first aid training from a recognized provider. Training can be obtained from the Canadian Red Cross (www.redcross.ca) or St. John Ambulance (www.sja.ca).

The 3 basic steps to follow in any emergency:

Remember: stay calm, look for dangers, never risk your own safety

CHECK the person

- Does the person want your help? If the person is unable to answer, assume you have consent to give first aid.
- Check the person's ABCs (Airway, Breathing, and Circulation).



CALL EMS/9-1-1

- If the person responds, find out if there is a need to call EMS/9-1-1.
- If the person does not respond, call for help and EMS/9-1-1.



CARE for life-threatening conditions first

- Reduce the risk of disease transmission by using protective equipment, such as disposable gloves and a barrier device.



Canadian Red Cross (2013). Check, Call, Care First Aid Poster. Retrieved February 2013, from Canadian Red Cross Web site: http://www.redcross.ca/cmslib/general/tp_fa_poster_checkcallcare_web.pdf



Medical Emergencies, continued

First Aid Information

CPR

The simplified Adult Basic Life Support algorithm includes five steps. The algorithm diagram provided by the American Heart Association emphasizes the following:

1. Assess the victim's responsiveness. If a victim is not breathing, or is not breathing normally (i.e., gasping), initiate CPR. Health care professionals should be trained to recognize cardiac arrest that presents as seizure-like activity or with agonal respirations.
2. Activate EMS (Emergency Medical Response) by calling 911.
3. Retrieve a defibrillator, usually an automatic external defibrillator (AED).
4. The algorithm proceeds in a loop of CPR and rhythm checks with defibrillation.
5. Check PULSE before chest compressions for at least five seconds and no more than ten seconds. If in doubt, begin compressions
6. CPR: push hard and fast. Begin chest compressions before ventilation. Chest compressions allow blood flow to the heart and brain. Delays in chest compressions result in diminished survival. Be sure to allow the chest to recoil between compressions. The chest should be compressed 100-120/min to a depth of 2"-2.4" (5-6cm)
7. For effective breathing, watch for chest rise and avoid excessive ventilation. 10 BREATHS should be delivered each minute, or one breath every six seconds. Each breath should be delivered over 1 second. Observe visible chest rise.
8. Avoid gastric inflation, as it may result in aspiration, pneumonia or vomiting.
9. The ratio of chest compressions to breaths is 30 to 2.
10. After the defibrillator becomes available, check rhythm. Use the AED when indicated and available. The victim should receive a shock that is repeated every two minutes or 5 cycles.

Burns

The American Red Cross recommends these steps to care for minor burns.

- Stop the burning. Put out the flames or remove the victim from the source of the burn.
- Cool the burn. Use large amounts of water to cool the burned area. DO NOT use ice or ice water other than on small superficial burns. Ice causes body heat loss. Use whatever resources are available: tub, shower or garden hose. You can apply soaked towels, sheets or other wet cloths to a burned face or other areas that cannot be immersed. Be sure to keep cloths cool by adding more water.
- Cover the burn. Use dry, sterile dressings or a clean cloth to cover a burn. Loosely bandage them in place. Covering the burn helps keep air out and reduces pain. Covering the burn also prevents infection. If the burn covers a large area of the body, cover it with clean, dry sheets or other cloth.

For minor burns and burns with open blisters that are not serious enough to need medical care, wash the areas with soap and water. Keep it clean. Put on an antibiotic ointment. Watch for signals of infection.



Medical Emergencies, continued

Burns, continued

Critical burns will need immediate medical attention. Call 911 or your emergency number if any one of the following instances occurs:

- Victim is having difficulty breathing.
- More than one part of the body is burned.
- There are burns to the head, neck, hands, feet or genitals.
- A child or an elderly person has been burned.
- Chemicals, electricity or explosions have caused the burns.

Chemical Exposure Guidelines

- In the event of chemical exposure, emergency services or poison control centre should be contacted as soon as possible.
- The eye may be irrigated using copious amounts of clean water, preferably using an eyewash bottle, eyewash station or shower.
- First aid providers may use continuous, large volumes of clean water for irrigation of chemical injuries where chemical exposure has occurred to other parts of the body.

Wounds & Abrasions Guidelines

- Superficial wounds and abrasions should be irrigated with clean water, preferably tap water because of the benefit of pressure.
- First aid providers may apply antibiotic ointment to skin abrasions and wounds to promote faster healing with less risk of infection.
- First aid providers may apply an occlusive dressing to wounds and abrasions with or without antibiotic ointment.
- The use of triple antibiotic ointment may be preferable to double- or singleagent antibiotic ointment or cream.
- If antibiotic is not used, antiseptic could be used.
- There is some evidence that traditional approaches, including applying honey, are beneficial and may be used on wounds by first aid providers.
- People with wounds that develop redness, warmth or become painful or with wounds where the person develops fever should seek assessment from a healthcare provider.



Medical Emergencies, continued

Bleeding Guidelines

- First aid providers must control external bleeding by applying direct pressure.
- The use of pressure points and elevation is NOT recommended.
- When direct pressure fails to control life-threatening external limb bleeding or is not possible (e.g. multiple injuries, inaccessible wounds, multiple casualties), tourniquets could be considered in special circumstances (such as disaster, war-like conditions, remote locations or in instances where specially trained first aid providers are providing care).
- Localized cold therapy with or without pressure may be beneficial in haemostasis for closed bleeding in extremities. Caution is advised when applying this recommendation to children due to a potential for hypothermia.
- The out-of-hospital application of a topical haemostatic agent to control lifethreatening bleeding not controlled by standard techniques and in situations where standard techniques could not be applied could be considered with appropriate training.

Source: www.redcross.ca/crc/documents/1303501_FirstAid-2016_Guidelines_LR-PDF.pdf



Medical Emergencies, continued

Next-of-Kin Notification

When an employee, contractor or member of the public is seriously injured, missing, or pronounced dead, the next-of-kin must be notified as promptly as possible. Keep in mind the following policies before notifying any next-of-kin:

- Death is never presumed, and first aid must be administered until relieved by a paramedic.
- No telephone or radio discussion is to take place regarding the name(s) of the injured.
- Notification is not to occur until the casualty has been pronounced dead by a medical doctor or medical examiner.

If an employee, contractor or member of the public is injured or killed as a result of company operations; notifications will be coordinated through local RCMP / municipal police and designated company personnel.

Before Notifying the Next-of-Kin

- Never release the names of the injured, missing, or persons pronounced dead before the next-of-kin are notified.
- Triple-check the identity of any casualty.
- If the casualty is conscious, document concerns. Do not make promises that cannot be kept.
- Confirm the casualty's relationship with the people being notified.
- Be prepared to support the next-of-kin. Provide assistance such as transportation, child care, alternative accommodation, reimbursements for daily expenses, and the temporary care of the family home if required.

During the Notification of the Next-of-Kin

- Make the notification in person, not by telephone or through an intermediary.
- Provide the relatives with as much information as possible; too few details can cause excessive worry. Present only the facts; do not speculate.
- Do not discuss personal views of liability or fault.
- Allow the next-of-kin to vent their emotions.
- Attempt to support and reunite families as quickly as possible.
- Offer assistance; document key issues and concerns. Do not make promises that cannot be kept. Follow up on relatives' requests.
- Document the details of anyone who appears to be having trouble coping with the incident so that he / she can be given prompt psychological support.



Medical Emergencies, continued

During the Notification of the Next-of-Kin, continued

- Do not leave the next-of-kin alone.
- Offer to contact a neighbour, friend, relative, minister, doctor, or counsellor.
- Leave your name and telephone number with family members.
- Ensure the next-of-kin are protected from media harassment as required.

Follow-Up

- The same representative who conducted the initial notification should continue to contact and support the next-of-kin.
- If required, a senior company representative will ensure that a trained psychologist conducts critical incident stress debriefing sessions with next-of-kin, friends and company employees involved or affected by the tragedy.
- Advise the employee's family that a senior company representative will be contacting them to discuss any immediate needs and to provide information on insurance coverage and benefits support. Follow up on this commitment.



Medical Evacuation (MEDEVAC) Procedure

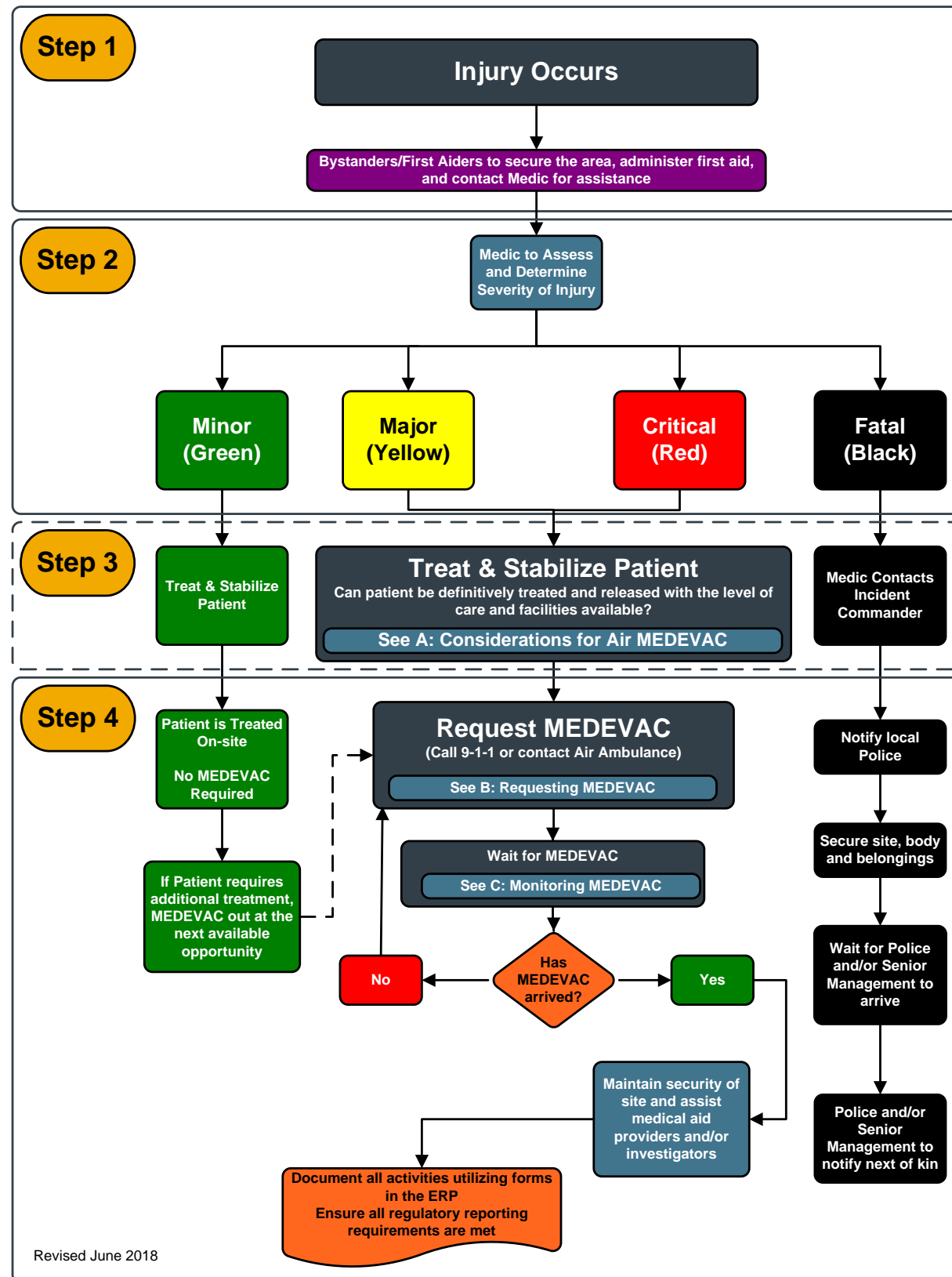

In the event of any injury or illness the following steps shall be followed:

1) Survey the scene and ask yourself the following questions:

- Is it safe for me to help?
- What happened?
- How many people are injured?

2) Call for help:

- 1) Activate Emergency Responders and/or call 9-1-1
- 2) Identify your location
- 3) Follow the direction of the Medic and administer First Aid if required and you are trained to do so
- 4) Review Step 1

Patient Priority Colour Code

The practice of colour coding patients is a useful tool to prioritize patients into categories depending on their medical condition. This colour code system allows ease of communicating the condition of the patient to those involved in the care and transportation of the patient.

Green – Patients with minor injuries or illnesses who are usually walking. Medical care can be delayed beyond 2 hours.

For example:

- Minor burns
- Sprains and strains
- Colds and flu symptoms

Yellow – Patients with major injuries or illnesses that should be treated within 20 minutes to 2 hours.

For example:

- Open fractures
- Large lacerations

Red – Patients with critical, life threatening injuries or illnesses that require treatment as soon as possible.

For example:

- Airway problems
- Severe hemorrhage
- Severe burns
- Failing vital signs

Black – Death is obvious. Note: resuscitation / treatment must continue until directed otherwise by a qualified medical provider. Await Police.

A: Considerations for Air MEDEVAC

Consider air transport when:

- Patient requires critical care life support during transport that is not available locally.
- Patient's condition requires that time spent in transport be as short as possible.
- Potential delays associated with ground transport (road obstacles or conditions, traffic, distance) are likely to worsen the patient's condition.
- Patient is located in an area inaccessible to regular ground transport.
- The use of medical transportation resources would leave the local area or worksite without adequate medical coverage.

B: Requesting MEDEVAC

When requesting MEDEVAC, be prepared to supply the following information:

- Location of patient pickup (facility, airport, road intersection, GPS)?
- Who will be meeting MEDEVAC crew (radio callsign / frequency, cell number)?
- Will the patient meet the MEDEVAC crew at the pickup location or will the MEDEVAC crew need to be transported to the patient?
- Any special equipment required (ventilator, bariatric transport equipment, etc.)?
- Will any additional personnel be necessary (physician, nurse)?
- Is there an intended destination (major hospital, community)?
- Has any consultation with medical providers at the intended destination been done?

Do not delay launch / dispatch of MEDEVAC, provide the following information once available:

- Mechanism of injury (and time of injury if known)
- Injury or illness sustained
- Symptoms and vital signs
- Treatment given

C: Monitoring MEDEVAC

When requesting MEDEVAC, ensure that you are monitoring the transport and are aware of who to contact for updates and in case changes to plan are required.

When is MEDEVAC transport scheduled to arrive?: _____

What number should be contacted if something in the plan needs to be changed? _____

If transport doesn't arrive, or if no updates are heard, what time will we contact MEDEVAC for an update? _____

Emergency MEDEVAC Phone Numbers

PROVINCIAL AIR AMBULANCE:

Alberta	800-661-3822
British Columbia	911
Manitoba	800-689-6559
Saskatchewan	888-782-8247

STARS (AB, BC, SK, MB):
24 Hour Emergency: 888-888-4567

Revised June 2018

Note: When a medical evacuation is complete all personnel must report to the Incident Commander for a debriefing session.



Responder Safety

Site Safety

Response personnel must stay out of the hazard area until the hazards are identified and assessed. All responders must evaluate potential site hazards including ignition sources or vapours gathering in low-lying areas such as ditches, trenches, and forested areas. The nature of a hazard will influence the responses. Therefore, the following characteristics about the hazard **must** be considered:

- The quantity and type of product involved.
- The potential for the situation to escalate.
- The location of the incident, the time of day and the weather conditions.
- Actual and perceived danger to responders, the public and the environment.
- The number of responders and their training.
- The availability of response equipment.
- The availability of external support, e.g. ambulances, police, fire fighters and mutual aid.

Responders **must** approach an incident site that may have gases or explosive vapours from an upwind or crosswind direction. They should inspect the site from a distance (using binoculars if possible) if hazards have not been assessed. When on-site, responders must take the following precautions:

- Identify safe escape routes away from hazardous areas.
- Continue to assess the related hazards, e.g. toxic vapours, fire or explosion hazards.
- Protect themselves and others (responders and public) before initiating control and containment operations.
- Do not allow anyone, including first responders such as police, fire fighters or ambulance attendants to enter the hazard area unless they are properly trained and equipped with personal protective equipment.
- Avoid extinguishing an ignited hydrocarbon release if the supply cannot be stopped.
- Only attempt fire control on small fires. Extensive fires or uncontrolled facility fires must be dealt with by external firefighting professionals. Responders must not attempt to battle a fire without adequate firefighting equipment, training, and backup personnel.
- Advise fire authorities when a company facility is threatened by an external fire. They should also be made aware of dangerous products or flammable hazards at the facility, such as pressurized NGL vessels, chemical and fuel storage.

Consider an outside expert when necessary. Well control, for example, is a specialty requiring specific experience, equipment, and procedures.



Responder Safety, continued

On-Site Work Areas

The On-Site Group Supervisor may choose to separate the site into three distinct areas to clearly identify the high-risk areas and to reduce the hazards to the on-site responders. The three areas could be defined as the safe area, the hazardous area, and the decontamination area.

Hazardous Area (Hot Zone)

Extreme caution and planning must be undertaken when entering the hazardous area. Access to and from the hazardous area will be controlled. Only personnel with appropriate personal protective equipment, training and an understanding of the specific response and control procedures will be allowed into the hazardous area. An example is confined space entry and rescue. Prior to entry into the hazardous area, all personnel should fully understand the goals, the method of on-site responder communication and the rescue plan.

The following guidelines help the On-Site Group Supervisor to determine the hazardous area. An area is considered hazardous if any of the following conditions exist:

- Combustible gas reading of 10% LEL or greater
- H₂S gas reading of 15 ppm or greater for 15 minutes
- SO₂ readings of 5 ppm or greater for 15 minutes
- Oxygen content of less than 19.5% or greater than 22%
- Presence of organic and inorganic vapours / gases and liquids (consult Safety Data Sheets (SDS) for toxicity data)
- An area the On-Site Group Supervisor deems to be hazardous, such as the area surrounding a fire or spill

The On-Site Group Supervisor will consider the following on-site conditions when determining the size of the hazardous area:

- The location of access routes, power lines, pipelines, fire, and explosion hazards
- Areas where vapours are likely to accumulate such a downwind areas, low areas, confined spaces
- Site stability, e.g. steep slopes, overhanging banks, unstable soil, thin ice
- Weather conditions
- The toxicity and evacuation data for the product involved (Refer to SDS)

Decontamination Area (Warm Zone)

Personnel responding to hazardous substance emergencies may become contaminated in several ways:

- Contacting vapours, gases, mists, or particulate in the air.
- Being splashed by materials while sampling or opening a container.
- Walking through puddles of liquids or on contaminated soil.
- Using contaminated instruments or equipment.



Responder Safety, continued

Decontamination is the complete or partial removal or neutralization of the harmful contamination chemicals. Some equipment will not withstand a proper decontamination process and therefore must be destroyed. Site safety personnel will recommend to the On-Site Group Supervisor whether clothing, instruments and equipment should be decontaminated or destroyed.

The decontamination area is usually set up in response to a hazardous material spill and when decontamination of personnel and equipment is required. The decontamination area buffers the designated hazardous and safe areas. Decontamination areas should be set up in areas that are not affected by the on-site hazard. Any contaminated personnel and equipment leaving the hazardous area must be decontaminated in the decontamination area before continuing to the safe area.

Equipment, solutions, and procedures required for decontamination depend on the type and degree of contamination. All hazardous waste must be disposed of according to applicable waste management regulations.

Safe Area (Cold Zone)

The safe area is an area verified by the On-Site Group Supervisor to be safe. The On-site Command Post (OSCP) is located in the safe area. The safe area must be continually monitored and evaluated to confirm its safety. If there is any concern about the area's safety, the On-site Command Post will relocate to an area proven to be safe.

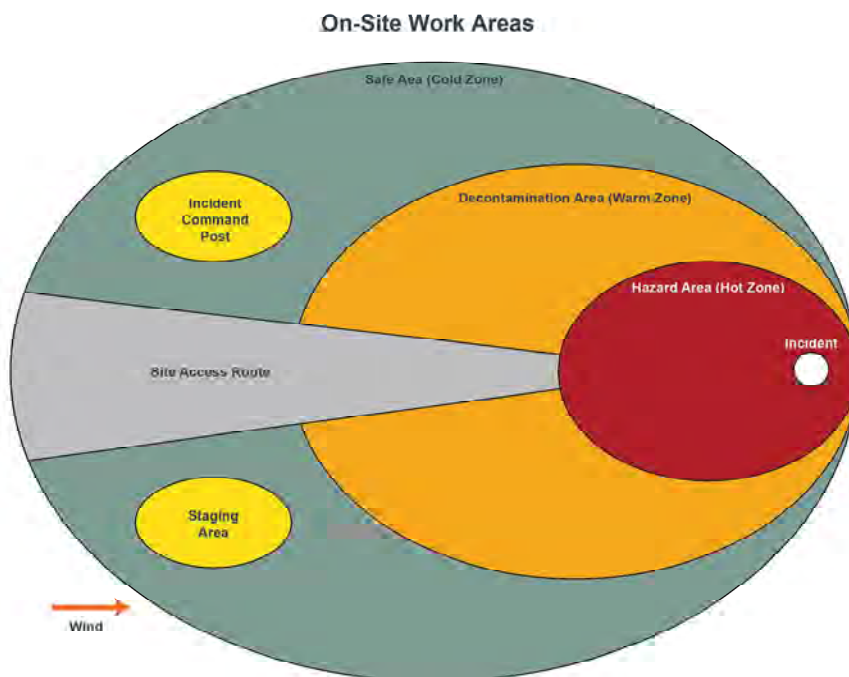



Responder Safety, continued

Working Alone

A Working Alone Procedure and a working alone hazard assessment are legislated responsibilities of every employer. One working alone hazard assessment may fit multiple work sites providing the working conditions are the same. These assessments must be available for the workers to review. All working alone hazards shall be mitigated to a reasonable and practical level of risk. Every worker who works alone must have a designated "Working Alone Contact". Activities, dates, and times of contact shall be documented and filed. The "Working Alone Contact" may be a co-worker, a 24/7 facility control room, a third-party emergency answering service, or automated working alone tracking system.

Application

Each operating area will develop a Site-Specific Procedure (SSP) for Working Alone; the SSP will be documented, approved by management, and signed by every company employee or contract employee working in that operating area. Service suppliers will be expected to provide their own "Working Alone Programs" but due to communication limitations or emergency response capabilities they may need to utilize the company Working Alone Program, this temporary change of "Working Alone Contact" should be documented on the safe work permit.

Potential Hazards

- Loss of communication needed for requesting assistance;
- Delays in reporting times;
- Injury requiring assistance; and
- Transportation problems.

Equipment and Training Requirements

- The Working Alone Procedure and Response Plan for the overdue worker are to be a specific agenda item for safety meetings to ensure a suitable level of acceptance and involvement from all personnel is achieved, and
- Supervisors and members of the management shall discuss the plan with workers that participate in field activities, to ensure a high level of awareness and preparedness is maintained at all times.

Low Risk Working Alone Procedure

(Sweet Gas Operations, daylight hours, normal weather conditions)

- The employee should notify their "Working Alone Contact" of check-in times and locations of work;
- If multiple travel routes are an option, then the route selected will also be noted
- If an employee's arrival at a check-in location is delayed by more than one (1) hour, the employee should notify their "Working Alone Contact" of the new estimated time of arrival.



Responder Safety, continued

High Risk Working Alone Procedure

(Sour Gas Operations, Call-outs, Adverse Weather Conditions)

- The employee should notify their "Working Alone Contact" prior to departure, and advise them contact of the estimated time of arrival at location;
- The employee should notify their "Working Alone Contact" of arrival at location;
- The employee should assess the problem or job scope, notify their contact, discuss the nature of the problem or job, work procedure to be used, and any additional required safeguards, and provide an estimation of how long they will be at the location;
- The employee should notify their "Working Alone Contact" when they are finished and ready to leave the location and estimated time of arrival at next check point, base or home; and
- The employee should notify their "Working Alone Contact" of arrival at next checkpoint, base or home.
- If the employee is delayed or expects to be delayed arriving at their next check-in point by more than one (1) hour, the employee should notify their "Working Alone Contact" of amended estimated time of arrival.
- During adverse weather conditions the employee should notify their "Working Alone Contact" of the exact route to be followed; shorter check-in time intervals are recommended.

Note: Every worker has both the right and responsibility to refuse unsafe work.

Overdue Worker Response Plan

- The Overdue Worker Response Plan shall be initiated when a worker is one (1) hour overdue, (shorter grace periods may be instituted during bad weather or at high risk worksites), and
- After the one (1) hour grace period has expired, the worker's "Working Alone Contact" shall:
 - Attempt to contact the overdue worker by cell phone or radio; immediately notify the worker's supervisor of the circumstances;
- The supervisor will discuss options with the "Working Alone Contact" and together they will agree on an action plan; and
- The action plan may include any or all of the following:
 - Continue attempts to contact the overdue worker by cell phone or radio;
 - The "Working Alone Contact" or other designated individual will drive the route taken by the overdue worker in an attempt to contact the worker. Specific PPE safety equipment may be required for rescue activities by those involved with the Overdue Worker Response Plan;
 - The "Working Alone Contact" or the supervisor may request search assistance from industry workers in the area who have been identified in the contact list;
 - The "Working Alone Contact" or supervisor will call local hospital(s) to establish whether an injured person has been admitted; and
 - The "Working Alone Contact" or supervisor may notify the local police or RCMP of circumstances with a request for assistance.



Responder Safety, continued

Missing Persons

In the event that an employee should go missing:

- Confirm that the person has failed to check in at the predetermined time.
- Contact the person's supervisor (or next in line for reporting) and provide details, e.g. where the person was working, length of time overdue, and if the person is alone.
- If it is deemed appropriate to initiate a search, inform a supervisor (or next in line for reporting) of any plans before any employees head out to search.
- Employees should never endanger themselves during a rescue.
- Searchers should always use the buddy system and work in teams. Each team must be fully equipped, names logged, and their designated search area recorded on a map before heading out. Searchers should carry maps and compass, GPS (Global Positioning System) unit, survival kit, first aid kit, communication equipment, extra batteries, and appropriate provisions.
- Search first where the missing person will most likely be found, e.g. where the person's truck is parked.
- If the missing person is not found within a specified time (e.g. two hours), notify the appropriate Search and Rescue (SAR) authority and/or local police.
- When formal SAR groups are engaged, it is imperative that only one person coordinates all operations.
- Notify ALL authorities when the missing person is found so all search participants are informed and can cease their efforts.
- Complete and submit the required accident/incident investigation form.

Source: PDAC Field Safety Pocket Guide

Rest Periods

Response members may experience a wide array of stresses which may include the death or serious injury of a co-worker, witnessing distressing sights, time pressures, responsibility overload, physical demands, mental demands, emotional demands, limited resources and high expectations from others, hazardous environments or extreme weather conditions.

In high-stress assignments, responders should be routinely rotated. Where manpower is limited, responders should alternate from high-stress positions to lower-stress positions.

Fifteen-to-thirty-minute rest periods should be scheduled every two hours during an emergency situation for all responders; and if possible, provided with:

- Shelter from weather, dry clothes, and a place to sit or lie down away from the scene.
- Warm food, high protein snacks and juices.
- An opportunity to share their feelings with co-workers.



Fire / Explosion

Fire Explosion Consideration

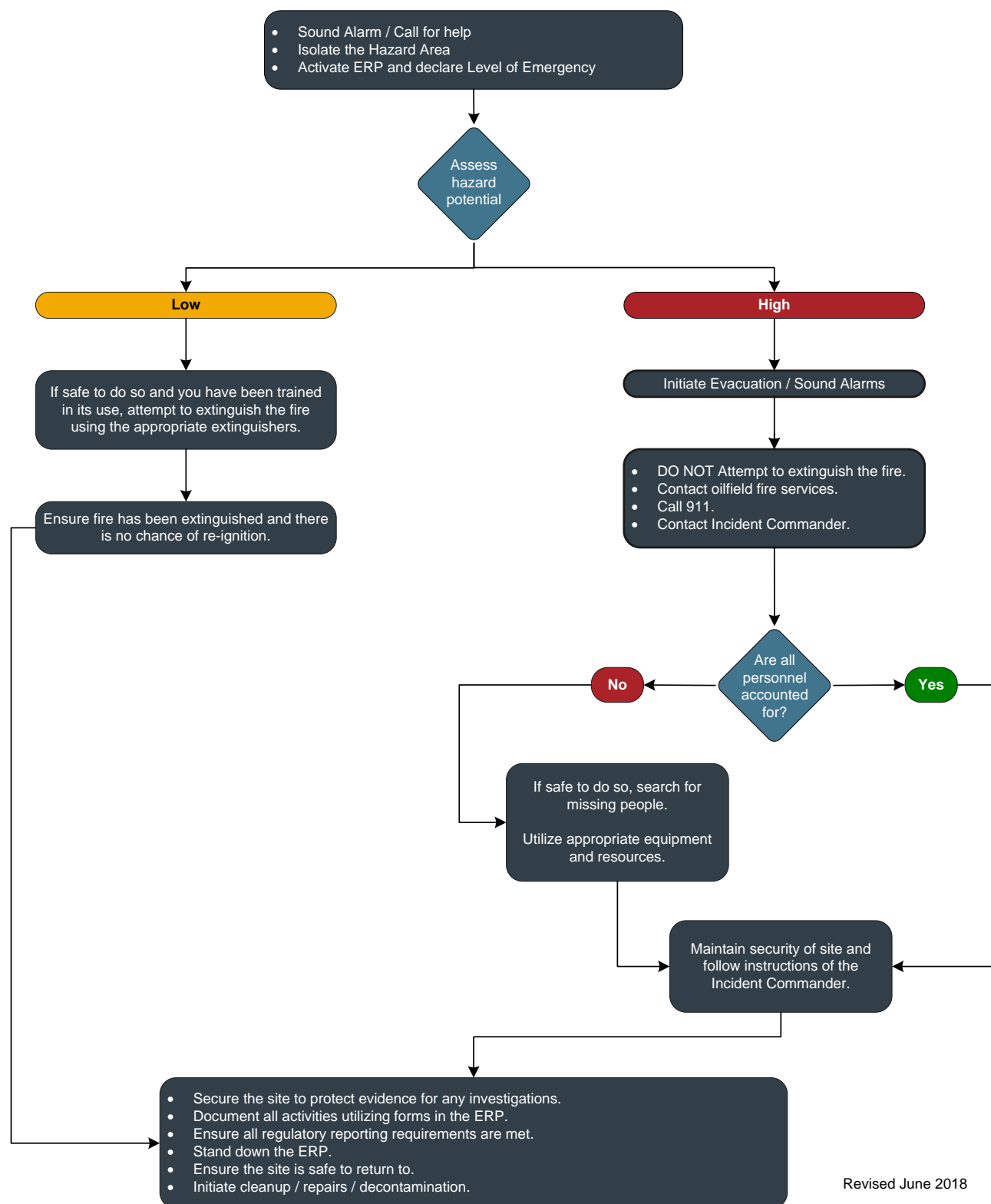

Revised June 2018



Fire / Explosion, continued

An explosion is a mechanical or chemical reaction that suddenly releases a large amount of energy, resulting in a shock or pressure wave that causes damage, high temperature and usually a release of gases. Explosions can be loosely categorized according to reaction time. High explosives react quickly within a millionth of a second, while low explosives react more slowly. Important general guidelines must be followed for all fires or explosions to ensure the safety of the public, employees and environment. When encountering different types of fire, the appropriate firefighting services should always be contacted. This is especially important for fuel-related, structure-related or forest-related fires to decrease the risk of major damage. For oil-related fires, industrial fire-fighters are the best equipped to reduce further danger in the area.

If a fire or explosion occurs, the following actions shall be taken:

Control / Containment:

- If possible;
 - Isolate the source and take reasonable action to extinguish or contain the fire.
 - Shut down all known fuel sources.
 - Shut off high voltage power supplies to equipment in fire-affected area.
 - Shut off fuel to heaters near to, or downwind of fire.
 - Dissipate static electrical charges on bodies of all personnel in area. Grounding may be accomplished by holding onto a metal structure for ten seconds with bare hands.
- Call out to industrial firefighting services.
- Notify the Incident Commander.
- Isolate hazard area or equipment as required.

External Notifications:

- Follow notification procedures for fires outlined in the Government Notification Matrix in **Section 5: External Agencies**.



Fire / Explosion, continued

Classification of Fires

Most fires that occur will fall into one or more of the following categories:

Class / Symbol	Material	Extinguishing Agent
 	Ordinary combustible materials, such as wood, paper, cloth, trash, and plastics.	Cooling, blanketing or wetting extinguishing agent is needed. Water and foam extinguishers work on this class of fire.
 	Flammable liquids such as gasoline, thinners, oil-based paints and greases; Also includes flammable gases such as propane and butane.	Extinguishers for this type of fire include carbon dioxide, dry chemical and halogenated or clean agent types.
 	Energized electrical equipment, such as motors transformers and appliances.	The most common type of extinguisher for this class is a carbon dioxide extinguisher. A dry chemical or clean agent extinguisher can also be used.
 	Combustible metals such as magnesium, sodium, potassium, titanium and aluminum.	Special dry powder extinguishing agents are required for this class of fire, and must be tailored to the specific hazardous metal.
 	Cooking oils and greases such as animal fats and vegetable fats.	A wet chemical fire extinguisher agent is used for this class of fire.

Source: www.femalifesafety.org



Fire / Explosion, continued

Response Actions Based on Type of Fire

Process Fire

Definition:

Process fires include those within or adjacent to: fractionation skids, compressors, exchangers, vessels (also see BLEVE / LPG), piping, tanks/bullets (also see BLEVE / LPG).

Hazards:

Process fires can be a particular hazard where flammable materials are present.

Response Actions:

Deny or restrict access to the area, shut down and depressurize any related or additional process equipment, if safe to do so. Do not attempt to extinguish a process fire if you are not properly trained.

Sulphur Fire

Definition:

Sulphur dust suspended in air ignites easily, and can cause an explosion in confined areas.

Hazards:

Toxic gases will form upon combustion. Bulk/solid forms burn only at a moderate rate, whereas dust burns with explosive violence. Burning sulphur decomposes into toxic sulphur oxide gases such as sulphur dioxide (SO₂) and hydrogen sulphide (H₂S) which is toxic if inhaled.

Response Actions:

The following precautions should be taken when dealing with sulphur fires:

- Prevent human contact or inhalation. Fire may produce irritating and/or toxic gases.
- Wear full faced, self-contained breathing apparatus and full protective clothing.
- Use a water fog, NOT water, to extinguish fire.
- Cool fire, surrounding area, and containers, tanks, and trucks to below 154°C in order to diminish the fire.
- Evacuate the area, except for essential personnel.
- Isolate the area with a 1600m radius.

Trained personnel, local fire departments or contract fire services should only attempt to control a sulphur fire. To ensure public protection, evacuate 1600 meters in all directions and ensure air monitoring is set up downwind of fire and the smoke plume. Continually assess evacuation zone based on air quality readings.



Fire / Explosion, continued

Electrical System Fire

Definition:

Electrical fires are fires involving potentially energized electrical equipment. This sort of fire may be caused by, for example, short-circuiting machinery or overloaded electrical cables.

Hazard:

Electrical fires can quickly get out of control and can cause serious damage and threaten lives.

Response Actions:

Electrical fire may be fought in the same way as an ordinary combustible fire, but water, foam, and other conductive agents are not to be used. While the fire is, or could possibly be electrically energized, it can be fought with any extinguishing agent rated for electrical fire. Carbon dioxide CO₂, FM-200 and dry chemical powder extinguishers such as PKP and even baking soda are especially suited to extinguishing this sort of fire. Once electricity is shut off to the equipment involved, it will generally become an ordinary combustible fire. Water conducts electricity; throwing water on an electrical fire can cause the fire to get larger.

Grass Fire

Definition:

A grass fire is a fire that burns large amounts of grass. They mainly occur in grasslands and or Great Plains.

Hazards:

Grassfires spread rapidly, travelling at speeds of up to 25 km/hr, and can quickly threaten lives and properties.

Response Actions:

Threatening grass fires have a potential to involve the licensee's and other area operators' facilities, pipelines and well sites, therefore guidelines to minimize damage to any property need to be followed. To protect the licensee's and other area user property, it is important to follow these guidelines:

- Notify other area operators of the emergency.
- Isolate and shut in all affected facilities if safe to do so.
- For small grass fires extinguish using a shovel or ABC type fire extinguisher. If it enters coulees, along rivers, or into large areas of trees or forests, contact the local fire department and local forestry office for assistance.
- For larger grass fires do not attempt to extinguish, but contact local fire department and local forestry office.



Fire / Explosion, continued

Forest Fire / Wildfire

Definition:

A forest fire is an uncontrolled fire in a wooded area. A forest fire is a natural disaster consisting of a fire which destroys a forested area, and can be a great danger to people who live in forests as well as wildlife. Forest fires are generally started by lightning, but also by human negligence or arson, and can burn thousands of square kilometres.

Hazards:

Forest fires can quickly get out of control and can cause serious damage in agricultural and forested lands.

Response Actions:

- Notify other area operators of the emergency.
- Isolate and shut in all affected facilities if safe to do so.
- For small fires extinguish using a shovel or ABC type fire extinguisher. If it enters coulees, along rivers, or into large areas of trees or forests, contact the local fire department and local forestry office for assistance.
- For larger fires do not attempt to extinguish the fire. To report a forest fire/wildfire, call:

British Columbia	1-800-663-5555 (Prov-wide) or *5555 (from cell, Prov-wide)
Alberta	310-FIRE (3473) (Prov-wide)
Saskatchewan	1-800-667-9660 (Prov-wide)
Manitoba	1-800-782-0076 (Prov-wide)
Northwest Territories	1-877-NWT-FIRE (698-3473) (Prov-wide)



Fire / Explosion, continued

Natural Gas Liquid Fire

Definition:

Liquid natural gas is very flammable after vaporization to a gaseous phase.

Hazard:

If liquid natural gas is spilled, it vaporizes. The natural gas vapours are initially heavier than air and they form a cloud close to the ground, which is pushed downwind and eventually dissipates. If a viable ignition source is present where a vapour cloud exists at a 5%–15% concentration in air, the vapour cloud can ignite and burn. A vapour cloud, formed by an LNG spill, could drift downwind into populated areas. An LNG fire gives off a tremendous amount of heat. Water will react violently with the LNG and may cause the fire to flare up and intensify.

Response Actions:

A solid stream of water should never be used to extinguish this type because it can cause the fuel to scatter, spreading the flames. The most effective way to extinguish a liquid or gas fueled fire is by inhibiting the chemical chain reaction of the fire, which is done by dry chemical and Halon extinguishing agents, although smothering with CO₂ or, for liquids, foam is also effective.

BLEVE

Definition:

BLEVE is an acronym for Boiling Liquid Expanding Vapour Explosion. It is the term for an uncontrolled fire and explosion of vapour as it escapes from a ruptured vessel of pressurized / liquefied gas. Such explosions can be extremely hazardous.

Hazards:

The hazards associated with a BLEVE include the initial impact of the blast, the fireball and radiation from the explosion and projectiles (pieces of the tank and nearby equipment) that are rocketed from the explosion.

Response Actions:

- Contact Emergency Response Assistance Canada (ERAC) for assistance with emptying any damaged tanks.
 - Under the plan, response is provided for the following chemicals: LPG - UN 1075, Propane - UN 1978, Butane - UN 1011, Propylene - UN 1077, Butylene - UN 1012, Isobutane - UN 1969, Isobutylene - UN 1055, Butadiene-1,3 - UN 1010
- If safe to do so, attempt to extinguish any fires before they come in contact with any storage bullets.
- Call 911 to obtain assistance with fire suppression. Ensure all responders are made aware of the hazards.
- Flowing water can be used to cool the tanks in order to prevent or delay a BLEVE; however, this requires a significant amount of water and should not be attempted unless an unlimited water supply can be located and the tank can be approached safely.
- Evacuate all personnel and isolate the area to a 1600m radius.
- Evaluate the tank from a safe distance away. Choose an upwind position to the side of the tank if possible.
- Leave the area immediately if you hear a rising sound from venting safety devices or see discoloration of the tank.



Fire / Explosion, continued

BLEVE Considerations Based on Tank Capacity

BLEVE																			
Capacity		Diameter		Length		Propane Mass		Minimum time to failure for severe torch	Approximate time to empty for engulfing fire	Fireball radius		Emergency response distance		Minimum evacuation distance		Preferred evacuation distance		Cooling water flow rate	
Litres	Gallons	Meters	Feet	Meters	Feet	kg	lbs	Minutes	Minutes	Meters	Feet	Meters	Feet	Metres	Feet	Meters	Feet	Litres/min	Gal/min
100	38.6	0.3	1	1.5	4.9	40	88	4	8	10	33	90	295	154	505	307	1007	94.6	25
400	154.4	0.61	2	1.5	4.9	160	353	4	12	16	53	90	295	244	801	488	1601	189.3	50
2000	772	0.96	3.2	3	9.8	800	1764	5	18	28	92	111	364	417	1368	834	2736	424	112
4000	1544	1	3.3	4.9	16.1	1600	3527	5	20	35	115	140	459	525	1722	1050	3445	598	158
8000	3088	1.25	4.1	6.5	21.3	3200	7055	6	22	44	144	176	577	661	2169	1323	4341	848	224
22000	8492	2.1	6.9	6.7	22	8800	19400	7	28	62	203	247	810	926	3038	1852	6076	1404	371
42000	16212	2.1	6.9	11.8	38.7	16800	37037	7	32	77	253	306	1004	1149	3770	2200	7218	1938	512
82000	31652	2.75	9	13.7	45	32800	72310	8	40	96	315	383	1257	1435	4708	2200	7218	2710	716
140000	54040	3.3	10.8	17.2	56.4	56000	123457	9	45	114	374	457	1499	1715	5627	2200	7218	3539	935



Transportation Incidents

First On-Scene Transportation (Road, Rail, Marine) Incident Flowchart

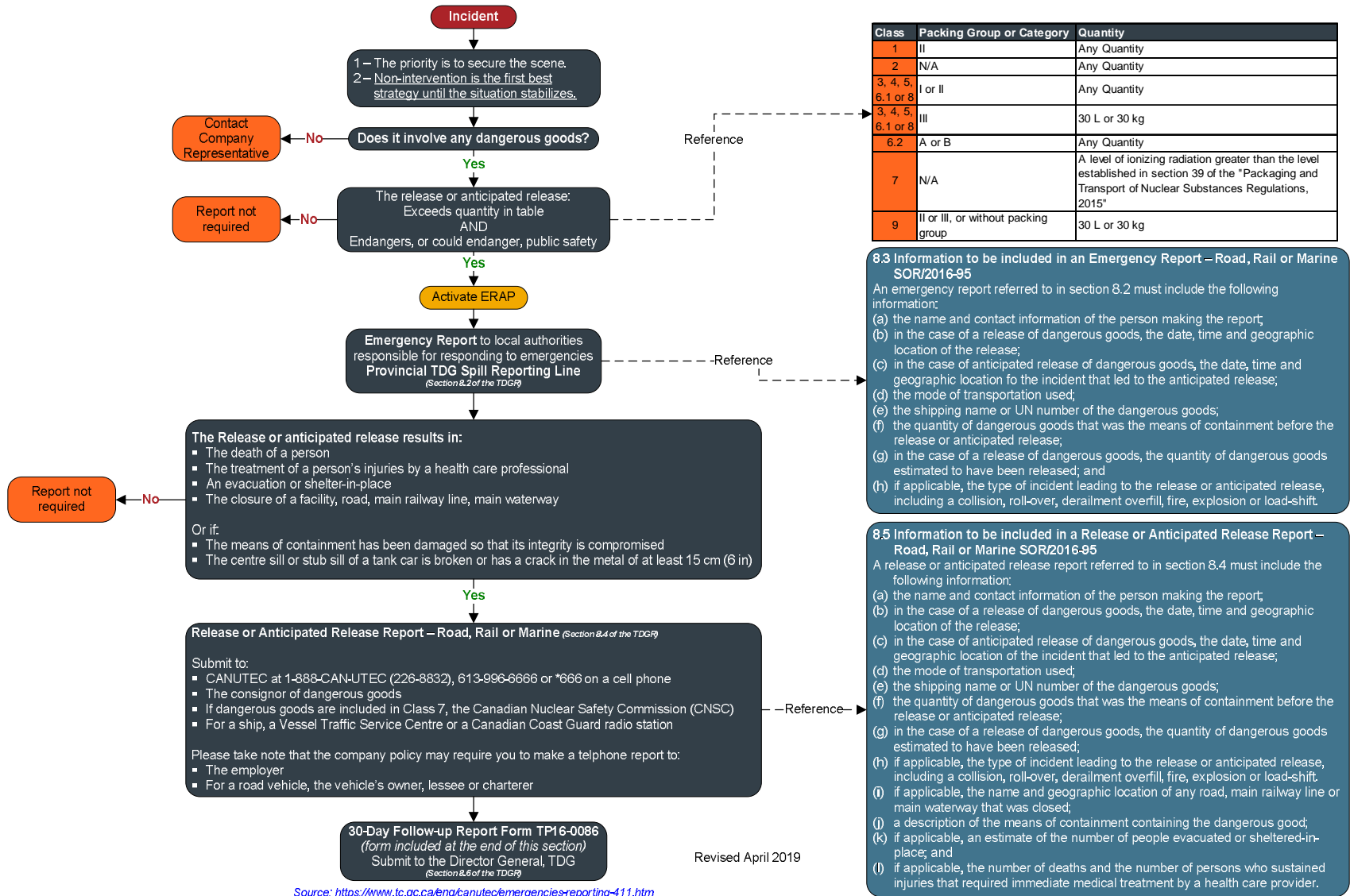

Class	Packing Group or Category	Quantity
1	II	Any Quantity
2	N/A	Any Quantity
3, 4, 5, 6.1 or 8	I or II	Any Quantity
3, 4, 5, 6.1 or 8	III	30 L or 30 kg
6.2	A or B	Any Quantity
7	N/A	A level of ionizing radiation greater than the level established in section 39 of the "Packaging and Transport of Nuclear Substances Regulations, 2015"
9	II or III, or without packing group	30 L or 30 kg

8.3 Information to be included in an Emergency Report – Road, Rail or Marine SOR/2016-95
An emergency report referred to in section 8.2 must include the following information:

- the name and contact information of the person making the report;
- in the case of a release of dangerous goods, the date, time and geographic location of the release;
- in the case of anticipated release of dangerous goods, the date, time and geographic location for the incident that led to the anticipated release;
- the mode of transportation used;
- the shipping name or UN number of the dangerous goods;
- the quantity of dangerous goods that was the means of containment before the release or anticipated release;
- in the case of a release of dangerous goods, the quantity of dangerous goods estimated to have been released; and
- if applicable, the type of incident leading to the release or anticipated release, including a collision, roll-over, derailment overflow, fire, explosion or load-shift.

8.5 Information to be included in a Release or Anticipated Release Report – Road, Rail or Marine SOR/2016-95
A release or anticipated release report referred to in section 8.4 must include the following information:

- the name and contact information of the person making the report;
- in the case of a release of dangerous goods, the date, time and geographic location of the release;
- in the case of anticipated release of dangerous goods, the date, time and geographic location of the incident that led to the anticipated release;
- the mode of transportation used;
- the shipping name or UN number of the dangerous goods;
- the quantity of dangerous goods that was the means of containment before the release or anticipated release;
- in the case of a release of dangerous goods, the quantity of dangerous goods estimated to have been released;
- if applicable, the type of incident leading to the release or anticipated release, including a collision, roll-over, derailment overflow, fire, explosion or load-shift.
- if applicable, the name and geographic location of any road, main railway line or main waterway that was closed;
- a description of the means of containment containing the dangerous good;
- if applicable, an estimate of the number of people evacuated or sheltered-in-place; and
- if applicable, the number of deaths and the number of persons who sustained injuries that required immediate medical treatment by a health care provider.

Source: <https://www.tc.gc.ca/eng/canutec/emergenciesreporting-411.htm>



Transportation Incidents, continued

Loss, Theft or Unlawful Interference Reporting Flowchart

Loss or Theft Report Protocol

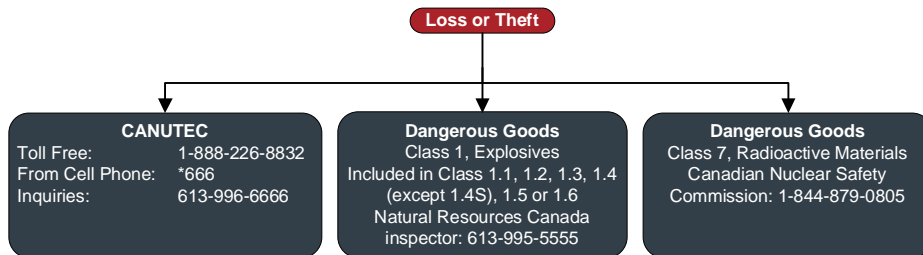

1. Any Quantity of Dangerous Goods in the following Primary and Subsidiary Classes:

- Explosives included in Class 1.1, 1.2, or 1.3
- Toxic gases included in Class 2.3
- Organic peroxides included in Class 5.2, Type B, liquid or solid, temperature controlled
- Toxic substances included in Class 6.1 and Packing Group I
- Infectious substances included in Class 6.2
- Radioactive materials included in Class 7

2. A Total Quantity of 450kg or more, in the case of Dangerous Goods in the following Primary and Subsidiary Classes:

- Explosives included in Class 1.4 (except for 1.4S), 1.5 or 1.6
- Flammable gases included in Class 2.1
- Flammable gases included in Class 3
- Desensitized explosives included in Class 3 or 4.1
- Substances liable to spontaneous combustion, pyrophoric solids or liquids, included in Class 4.2 and Packing Group I or II
- Water-reactive substances included in Class 4.3 and Packing Group I or II
- Oxidizing substances included in Class 5.1 and Packing Group I or II
- Corrosives included in Class 8 and Packing Group I or II

3. Any Quantity of one of these Dangerous Goods:

- UN1261, Nitromethane,
- UN1357, Urea Nitrate, Wetted with not less than 20%,
- UN1485, Potassium Chlorate,
- UN1486, Potassium Nitrate,
- UN1487, Potassium Nitrate and Sodium Nitrate Mixture,
- UN1489, Potassium Perchlorate,
- UN1495, Sodium Chlorate,
- UN1498, Sodium Nitrate,
- UN1499, Sodium Nitrate and Potassium Nitrate Mixture,
- UN1511, Urea Hydrogen Peroxide,
- UN1796, Nitrating Acid Mixture with more than 50% nitric acid,
- UN1826, Nitrating Acid Mixture, Spent, with not more than 50% nitric acid,
- UN1942, Nitrating Acid Mixture, with not more than 0.2% combustible substances, including any organic substance calculated as carbon, to the exclusion of any other added substance,
- UN2014, Hydrogen Peroxide, Aqueous Solution with not less than 20% but not more than 60% hydrogen peroxide (stabilized as necessary),
- UN2015, Hydrogen Peroxide, Aqueous Solution, Stabilized with more than 60% hydrogen peroxide; or Hydrogen Peroxide, Stabilized,
- UN2031, Nitric Acid, other than red fuming
- UN2032, Nitric Acid, Red Fuming
- UN3149, Hydrogen Peroxide and Peroxyacetic Acid Mixture with acid(s), water and not more than 5% peroxyacetic acid, Stabilized
- UN3370, Urea Nitrate, Wetted, with not less than 10% water by mass.

Reference

Unlawful Interference Report Protocol

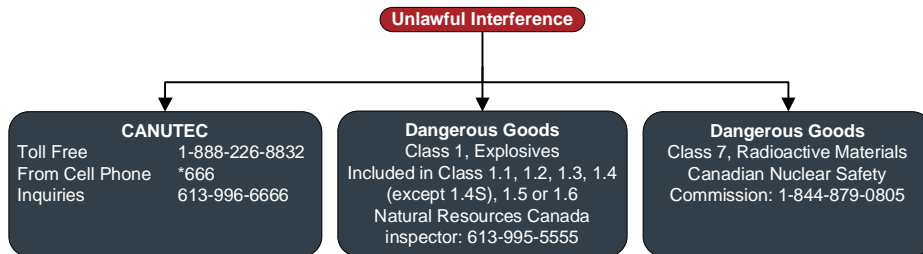

Revised June 2018



Transportation Incidents, continued

Motor Vehicle Accidents

The first person on scene will follow the First Person On-Scene Transportation Incident Flowchart, then:

- Record and report the following:
 - Driver's name, address and phone number.
 - Driver's license number.
 - Vehicle license plate number, make, model, year and colour.
 - Name of injured and nature of injury.
 - Witnesses' name, address and phone numbers.
 - Time and location of accident.
 - Actions taken.
 - Weather conditions.
 - Individuals and organizations notified.
- Make a statement to the RCMP / police.
- Chronologically document all actions, decisions, contacts and requests on an ICS 214 Activity Log (see **Section 6: Forms**).

The Incident Commander will be engaged through the initial notification and is responsible to:

- Ensure required communication occurs with internal and external personnel.
- Ensure no unauthorized personnel enter the emergency area.
- Ensure evidence is secured for investigation.
- Conduct an initial debriefing to all emergency personnel and delegate areas of responsibility.
- Chronologically document all actions, decisions, contacts and requests on an ICS 214 Activity Log (refer to **Section 6: Forms**).

In case of a hazardous material spill:

- Ensure your own personal safety.
- Refer to **Section 4: Spill Response**.

In case of a vehicle fire:

- Ensure your own personal safety.
- Call for assistance.
- Use an ABC fire extinguisher for cab, electrical, cargo space or trunk and engine fires.

Note: RCMP/Police must be notified when an injury or fatality has occurred and / or vehicle damages exceed \$1000.00.



Transportation Incidents, continued

Refer to the Transport Canada - 2020 Emergency Response Guidebook for further details regarding the Initial Phase of a Dangerous Goods / Hazardous Materials Transportation Incident.

Emergency Response Assistance Canada (ERAC) Plan

Internal notification is required in the event of a LPG incident. The extent of the notification depends on the severity of the incident. If the Emergency Response Assistance Canada (ERAC) Plan has been implemented, the incident is considered serious. Examples of serious incidents include: fire, spill, rupture, collision involving tanker car, tanker car overturning, etc.

Notification of an LPG incident outside of a plant site will most likely come from Emergency Response Assistance Canada (ERAC) in Calgary, Alberta.

If the call is NOT from ERAC, contact ERAC immediately and confirm the plan has been initiated.

If you receive the initial call, contact the ERAC:

- Refer to **Section 5: External Agencies** or **Area Specific Information** for contact information

Refer to the First On-Scene Incident Flowchart on the previous page for information on when to contact.

CANUTEC – Canadian Transport Emergency Centre

CANUTEC is operated by Transport Canada to assist emergency response personnel in handling dangerous goods emergencies involving all modes of transportation.

In an emergency, CANUTEC may be called collect at:

- Refer to **Section 5: External Agencies** or **Area Specific Information** for contact information

CANUTEC **MUST** be notified in the case of the following:

- Lost, stolen or misplaced infectious substances.
- An incident involving infectious substances.
- An accidental release from a cylinder that has suffered a catastrophic failure.
- An incident where the shipping documents display CANUTEC's telephone number as the emergency number.
- A dangerous goods incident in which a railway vehicle, a ship, an aircraft, an aerodrome or an air cargo facility is involved.



Transportation Incidents, continued

Dangerous Goods References

Agency Contacts

Although technical information and emergency response assistance can be obtained from CANUTEC, there are federal and provincial regulations requiring the reporting of dangerous goods incidents to certain authorities.

- Refer to **Section 5: External Agencies** or **Area Specific Information** for contact information

Note: The nearest police department must be notified in the case of lost, stolen or misplaced explosives, radioactive materials or infectious substances.

The appropriate federal agencies must be notified if affected:

- Refer to **Section 5: External Agencies** or **Area Specific Information** for contact information

TDG Reportable Quantities

Refer to Petroleum Release Reporting Requirements chart in **Section 4: Spill Response**.

Transportation Incidents, continued

Rail Car Identification Chart

117 Pressure tank car

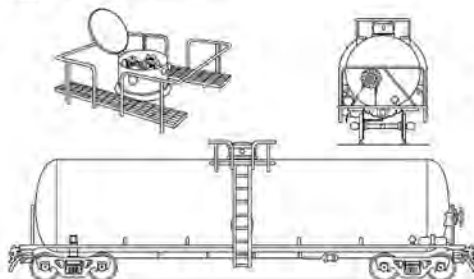

- For flammable, non-flammable, toxic and/or liquefied compressed gases
- Protective housing
- No bottom fittings
- Pressures usually above 40 psi

131 Non-pressure / low pressure tank car

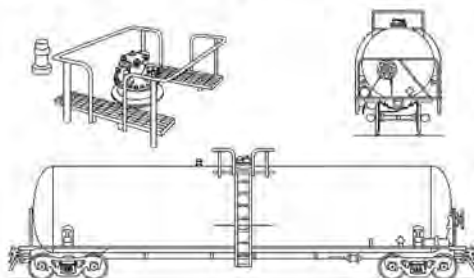

- Known as **general service tank car**
- For variety of hazardous and non-hazardous materials
- Fittings and valves normally visible at the top of the tank
- Some may have bottom outlet valve
- Pressures usually below 25 psi

128 Non-pressure / low pressure tank car (TC117, DOT117)

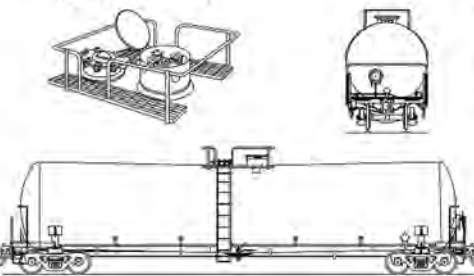

- For flammable liquids (e.g., Petroleum crude oil, ethanol)
- Protective housing separate from manway
- Bottom outlet valve
- Pressures usually below 25 psi

111 Box car

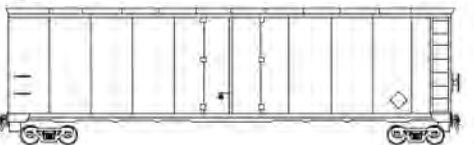

- For general freight that carry bulk or non-bulk packages
- May transport hazardous materials/dangerous goods in small packages or "tote bins"
- Single or double sliding door

140 Hopper car

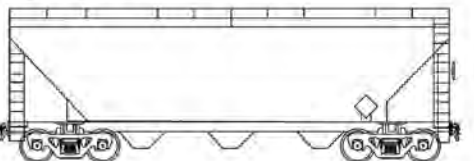

- For bulk commodities and bulk cargo (e.g., coal, ore, cement and solid granular materials)
- Bulk lading discharged by gravity through the hopper bottom doors when doors opened

Transportation Incidents, continued

Rail Car Identification Chart, continued

COMMON MARKINGS ON RAIL CARS: reporting marks and car number, load limit (pounds or kilograms), empty weight of car, placard, tank qualification and pressure relief device information, car specification, and commodity name.

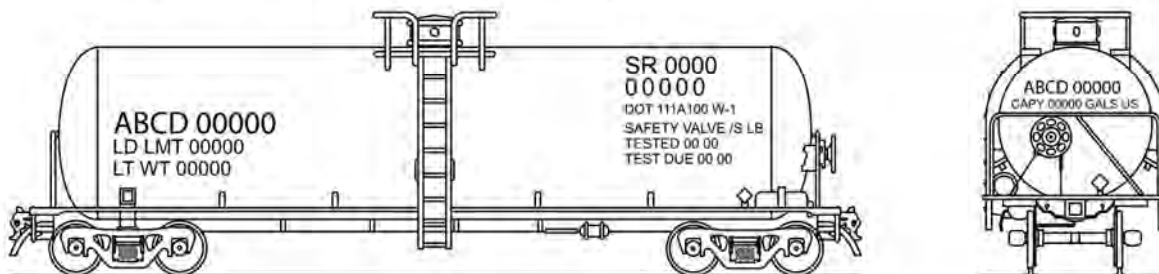

CAUTION: Emergency response personnel must be aware that rail tank cars vary widely in construction, fittings and purpose. Tank cars could transport products that may be solids, liquids or gases. The products may be under pressure. It is essential that products be identified by consulting shipping documents or train consist or contacting dispatch centres before emergency response is initiated.

The information stencilled on the sides or ends of tank cars, as illustrated above, may be used to identify the product utilizing:

- a. the commodity name shown; or
- b. the other information shown, especially reporting marks and car number which when supplied to a dispatch centre, will facilitate the identification of the product.

The recommended guides should be considered as last resort if the material cannot be identified by any other means.

Source: 2020 Emergency Response Guidebook



Transportation Incidents, continued

Road Trailer Identification Chart

WARNING: Road trailers may be jacketed, the cross-section may look different than shown and external ring stiffeners would be invisible.

NOTE: An emergency shut-off valve is commonly found at the front of the tank, near the driver door.

117 MC331, TC331, SCT331

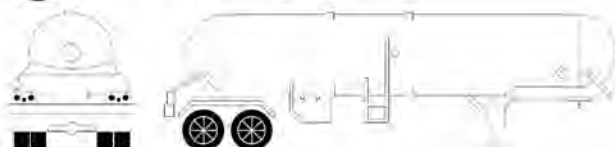

- For liquefied compressed gases (e.g., LPG, ammonia)
- Rounded heads
- Design pressure between 100-500 psi

117 MC338, TC338, SCT338, TC341, CGA341

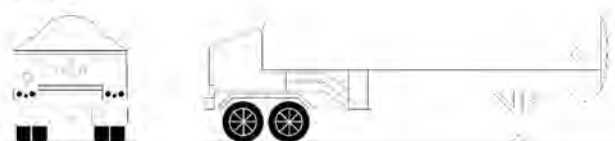

- For refrigerated liquefied gases (cryogenic liquids)
- Similar to a "giant thermo-bottle"
- Fitting compartments located in a cabinet at the rear of the tank
- MAWP between 25-500 psi

131 DOT406, TC406, SCT306, MC306, TC306

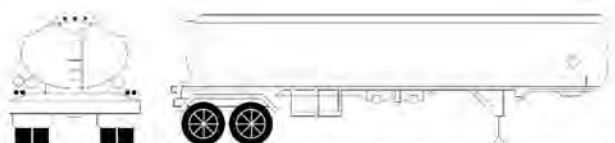

- For flammable liquids (e.g., gasoline, diesel)
- Elliptical cross-section
- Rollover protection at the top
- Bottom outlet valves
- MAWP between 3-15 psi

137 DOT407, TC407, SCT307, MC307, TC307



- For toxic, corrosive, and flammable liquids
- Circular cross-section
- May have external ring stiffeners
- MAWP of at least 25 psi

137 DOT412, TC412, SCT312, MC312, TC312



- Usually for corrosive liquids
- Circular cross-section
- External ring stiffeners
- Tank diameter is relatively small
- MAWP of at least 15 psi

Transportation Incidents, continued

Road Trailer Identification Chart, continued

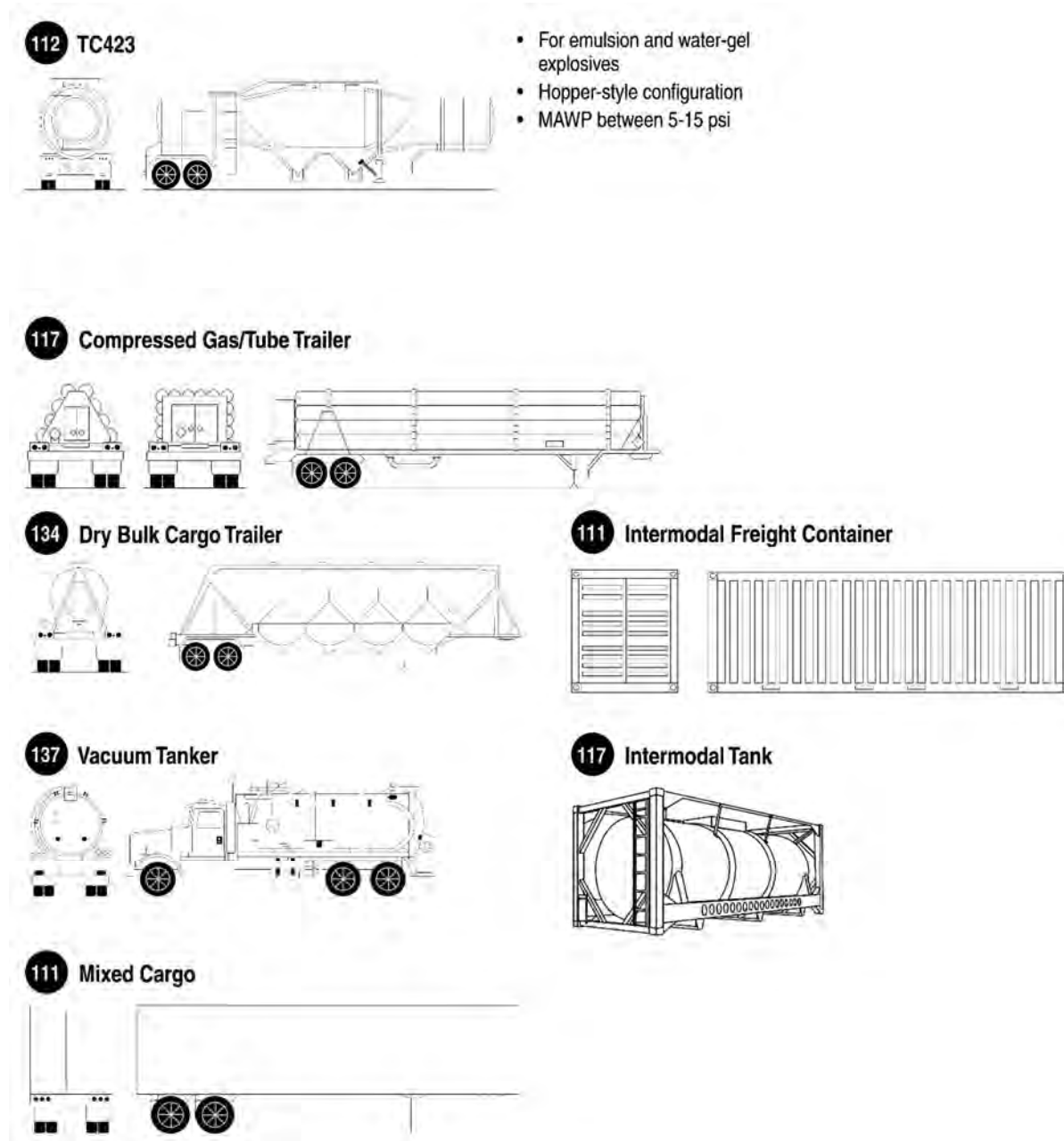

CAUTION: This chart depicts only the most general shapes of road trailers. Emergency response personnel must be aware that there are many variations of road trailers, not illustrated above, that are used for shipping chemical products. The suggested guides are for the most hazardous products that may be transported in these trailer types.

The recommended guides should be considered as last resort if the material cannot be identified by any other means.

Source: 2020 Emergency Response Guidebook

Transportation Incidents, continued

Table of Markings, Labels, and Placards

Use this table only if materials cannot be specifically identified by using the shipping paper, numbered placard, or orange panel number.

111 DANGEROUS (Red diamond)

111 Y (White diamond with black border)

111 Air only (White diamond with black border)

111 All other modes (White diamond with black border)

112 Explosives (Orange diamond)

112 1.5 (Orange diamond)

112 1.5 BLASTING AGENTS (Orange diamond)

For Divisions 1.1, 1.2, 1.3 and 1.5, enter division number (**) and compatibility group letter (*), when required.

114 1.4 (Orange diamond)

114 1.4 EXPLOSIVES (Orange diamond)

114 1.6 EXPLOSIVES (Orange diamond)

114 1.6 (Orange diamond)

For Divisions 1.4 and 1.6, enter compatibility group letter (*), when required.

118 2 (Red diamond)

118 2 (Red diamond)

118 FLAMMABLE GAS (Red diamond)

120 2 (Green diamond)

120 2 (Green diamond)

120 NON-FLAMMABLE GAS (Green diamond)

120 2 (Green diamond)

122 2 (Yellow diamond)

122 2 (Yellow diamond)

122 OXYGEN (Yellow diamond)

123 2 (White diamond)

123 INHALATION HAZARD (White diamond)

123 INHALATION HAZARD (White placard)

125 2 (White diamond)

125 1005 (White diamond)

127 3 (Red diamond)

127 3 (Red diamond)

127 COMBUSTIBLE (Red diamond)

127 3 (Red diamond)

127 3 (Red diamond)

127 3 (Red diamond)

128 HOT (White diamond)

128 3 (Red diamond)

128 3 (Red diamond)

128 3 (Red diamond)

128 3 (Red diamond)

128 FUEL OIL (Red diamond)

128 GASOLINE (Red diamond)

128 (Red triangle)

Transportation Incidents, continued

Table of Markings, Labels, and Placards, continued

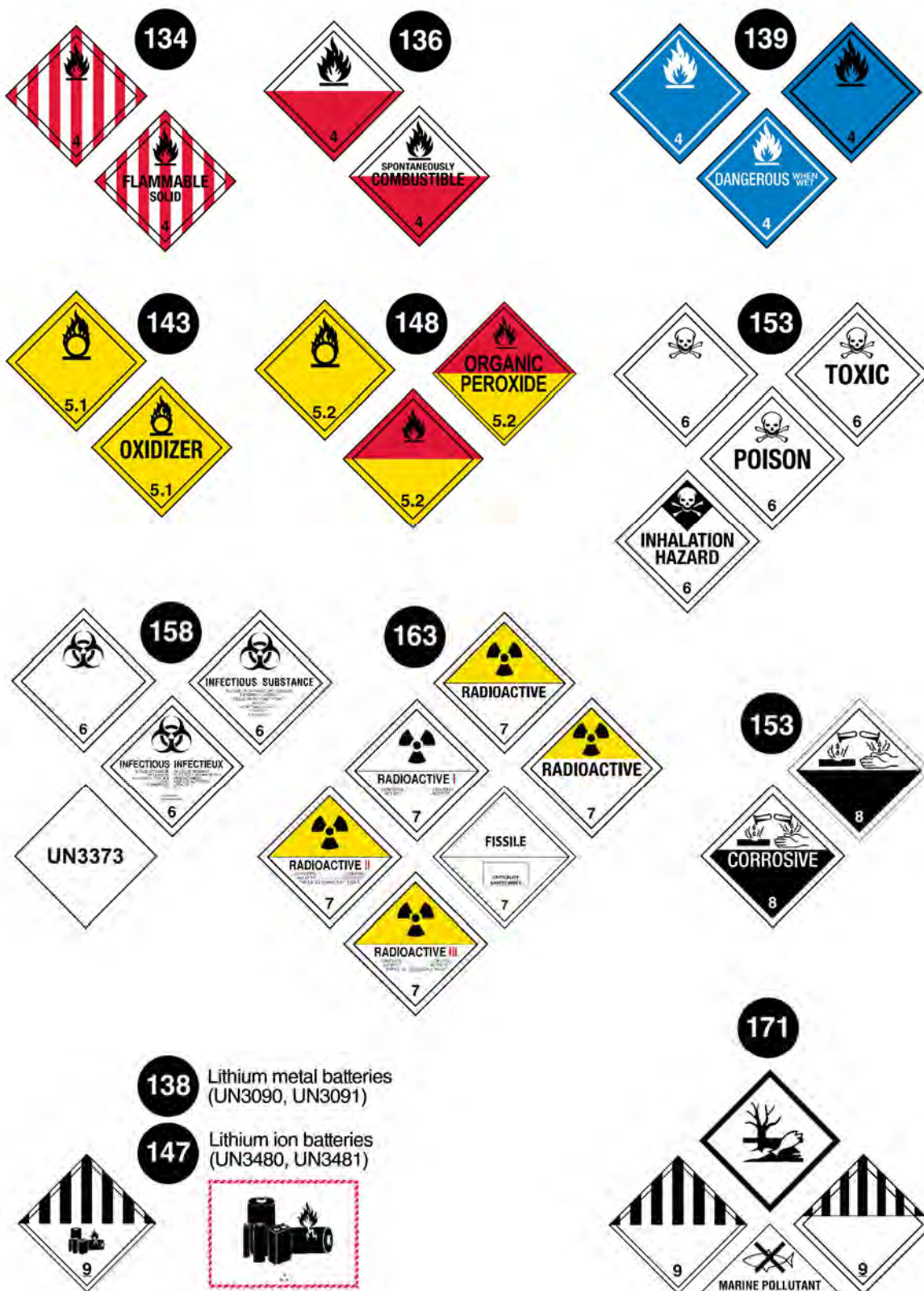



TRANSPORTATION OF DANGEROUS GOODS 30-DAY FOLLOW-UP REPORT

PART I: REPORTING TIMELINE			
1. Please provide applicable dates and check one box Date of initial report to CANUTEC (yyyy-mm-dd): _____ 30-Day Follow-up Report submission date (yyyy-mm-dd): _____ <input type="radio"/> 30-Day Follow-up Report <input type="radio"/> Update or amendment to 30-Day Follow-up Report • Date original 30-Day Follow-up Report submitted (yyyy-mm-dd): _____			FOR INTERNAL USE ONLY Road, Rail or Marine Reports <input type="radio"/> Release <input type="radio"/> Anticipated Release Air Report <input type="radio"/> Dangerous Goods Accident or Incident
PART II: CONTACT INFORMATION			
2. Information of the person completing this report <input type="checkbox"/> Consignor <input type="checkbox"/> Consignee <input type="checkbox"/> Carrier/Aircraft Operator <input type="checkbox"/> Other			
First Name	Last Name	Title	
Telephone (999-999-9999)	Company Name		
Address		City	Province/Territory
Country	Postal Code (Z9Z 9Z9)	Email	
3. Information on the Consignor, Consignee and Carrier/Aircraft Operator			
Consignor			
First Name	Last Name	Title	
Telephone (999-999-9999)	Company Name		
Address		City	Province/Territory
Country	Postal Code (Z9Z 9Z9)	Email	
Consignee			
First Name	Last Name	Title	
Telephone (999-999-9999)	Company Name		
Address		City	Province/Territory
Country	Postal Code (Z9Z 9Z9)	Email	
Carrier/Aircraft Operator			
First Name	Last Name	Title	
Telephone (999-999-9999)	Company Name		
Address		City	Province/Territory
Country	Postal Code (Z9Z 9Z9)	Email	

PART III: INCIDENT INFORMATION			
4. Please indicate the date and time of the incident			
Date (yyyy-mm-dd)		Time (24-hour system)	
5. Geographic location of the incident			
Address			
City	Province/Territory	Postal Code (Z9Z 9Z9)	GPS Position
If the incident occurred by rail, please indicate the milepost and subdivision		If the incident happened on First Nations Territory, please indicate the Territory name	
Origin of consignment		Destination of consignment	
<input type="radio"/> Same address as consignor <input type="radio"/> Same address as consignee <input type="radio"/> Other (please provide address):		<input type="radio"/> Same address as consignor <input type="radio"/> Same address as consignee <input type="radio"/> Other (please provide address):	
6. Geographic Area (Check only one box)			
<input type="radio"/> Urban Mixed use – residential, commercial <input type="radio"/> Suburban Primary residential <input type="radio"/> Rural Small towns, villages, agricultural lands <input type="radio"/> Wilderness/Remote Little or no population			
7. Mode of Transport (Check all applicable boxes)			
<input type="checkbox"/> Road <input type="checkbox"/> Rail <input type="checkbox"/> Air <input type="checkbox"/> Marine			
8. If MARINE was checked on question 7, please indicate the position of the vessel and the next location at which the vessel will be at anchor or alongside a fixed facility			
Position		Next location	
9. Phase of Transport (Check only one box)			
<input type="radio"/> In-Transit Consignment moving between origin and destination <input type="radio"/> Unloading Consignment is being unpacked or unloaded from a means of transport at destination		<input type="radio"/> Loading Consignment is being packed or loaded into a means of transport at origin <input type="radio"/> Temporary Storage Consignment is in short term storage pending transportation	
10. Type of Incident (Check all applicable boxes)			
<input type="checkbox"/> Collision/Sideswipe Moving vehicles striking an object, animal, or another vehicle <input type="checkbox"/> Ran off road Vehicle enters a soft shoulder, ditch or similar area <input type="checkbox"/> Loadshift Shifting of the consignment within a vehicle <input type="checkbox"/> Struck Means of containment being struck by another object		<input type="checkbox"/> Derailment Railcar leaving the rail tracks <input type="checkbox"/> Overturn Vehicle turning on its side or upside down <input type="checkbox"/> Dropped Means of containment falling unexpectedly <input type="checkbox"/> Other (Please specify): _____	
11. Type of Release (Check all applicable boxes)			
<input type="checkbox"/> Spill Quick, immediate discharge, emission or escape <input type="checkbox"/> Explosion Violent sudden release of energy from means of containment producing a shock wave that may result in fragment projection and/or fire ball <input type="checkbox"/> BLEVE Boiling Liquid Expanding Vapour Explosion <input type="checkbox"/> Venting Controlled release of gas into the environment		<input type="checkbox"/> Leak Slow, sporadic or continuous discharge, emission or escape <input type="checkbox"/> Fire Burning substances combined with oxygen to typically produce flame, heat and smoke <input type="checkbox"/> Vapour Dispersion in air of particles of a substance that is liquid or solid in its normal state <input type="checkbox"/> Anticipated Release Distressed means of containment that is not leaking, venting or otherwise releasing its contents	

12. Information on the Dangerous Goods								
UN Number	Shipping Name	Primary Class	Subsidiary Class(es)	Packing Group or Category	Total Quantity in MOC Before the Release or Anticipated Release	Units (kg, L, etc.)	Estimated Quantity Released (if applicable)	Units (kg, L, etc.)

13. Means of Containment
Please provide a description of the means of containment involved in the incident by completing the appropriate forms from Annex E of the Guide (TP15294)

PART IV: CONSEQUENCES

14. Consequences of the incident (Check all applicable boxes)

NOTE: Refer to the Guide for more information on how to complete this section

Human Property (e.g. product loss, facility, equipment) Environmental (e.g. contamination of waterway, ground, air)

15. Evacuation of people and buildings/Shelter in place

Was there an Evacuation as a result of the incident? Yes No

Was there Shelter in place as a result of the incident? Yes No

If **Yes**, please complete the following table

Evacuation of People and Buildings/Shelter in Place	Private Residence Includes houses and other buildings used as dwellings (e.g. Retirement homes)	Public Buildings Includes libraries, hospitals, churches, government buildings, etc.	Workplace Includes warehouse, facility, etc.	Public (Outside) Areas Includes parks, playgrounds, parking lots, etc.
Estimated number of people evacuated				
Estimated number of people sheltered in place				
Estimated number of buildings evacuated				
Size of Evacuation area (square meters)	Duration of Evacuation (hours)		Duration of Shelter in place (hours)	

16. Injuries and/or deaths

Were there any injuries and/or deaths? Yes (please complete the following table) No

Minor Injuries Yes No

Number of injured requiring immediate first aid treatment at the scene

Attributed to Dangerous Goods	Attributed to incident	Total

Moderate Injuries Yes No

Number of injured requiring immediate emergency treatment in hospital and release shortly after

Attributed to Dangerous Goods	Attributed to incident	Total

Major Injuries Yes No

Number of injured requiring immediate treatment with overnight hospitalization

Attributed to Dangerous Goods	Attributed to incident	Total

Deaths Yes No

Number of deaths

Attributed to Dangerous Goods	Attributed to incident	Total

17. Please indicate an estimate of costs in Canadian dollars associated with the incident, as applicable

NOTE: Refer to the Guide for more information on how to fill this section

Material loss of dangerous goods	Damage incurred by the carrier	Property damage	Emergency response cost	Clean-up cost	Total cost
----------------------------------	--------------------------------	-----------------	-------------------------	---------------	-------------------

18. Infrastructure closure and duration (please use additional sheets for multiple closures)

Was there an infrastructure closure as a result of the incident? Yes No

If **Yes**, please complete the following table

Type	Duration of the closure (in hours)
<input type="checkbox"/> Aerodrome – Area of land, water or other supporting surface used either in whole or in part for arrival and departure, movement or servicing of aircraft includes any building, installations and equipment situated thereon or in connection therewith	
<input type="checkbox"/> Air cargo facility – Facility used to receive or transfer cargo carried or to be carried by an aircraft	
<input type="checkbox"/> Facility – Permanent or temporary building or a portion of a building or equipment used in loading or unloading of dangerous goods	
<input type="checkbox"/> Railway – Tracks used by trains	
<input type="checkbox"/> Waterway – Navigable body of water through which a ship or boat can move	
<input type="checkbox"/> Roadway – The strip of land over which motor vehicles circulate, such as dirt road, numbered provincial highway or multiple lane freeway	
<input type="checkbox"/> Runway – the strip of ground on a landing field that aircraft use for landing or takeoff	

19. Geographic location of closure

Address

City	Province/Territory	Postal Code (Z9Z 9Z9)	GPS Position
------	--------------------	-----------------------	--------------

If the incident occurred by rail, please indicate the milepost and subdivision

Name of facility, road, railway or waterway

20. ERAP Requirements

Was an ERAP required under Part 7 of the *Transportation of Dangerous Goods Regulations*? Yes No

If **Yes**, please complete the following table

ERAP Reference Number	ERAP Holder
-----------------------	-------------

Address

City	Province/Territory	Postal Code (Z9Z 9Z9)	Telephone of ERAP Holder (999-999-9999)
------	--------------------	-----------------------	---

Email

Level of Response (check all that apply)

No response First responders on scene Phone call to ERAP holder Employee from ERAP holder Team from ERAP holder

Other: _____

PART V: INCIDENT DESCRIPTION

21. Please describe:

- The sequence of events that led to the incident
- The means of containment damage or failure, including the size/location of holes, cracks, etc.
- The actions taken at the time it was discovered
- What was done to mitigate the effects of the release
- Contributing factors (e.g. human error, mechanical, equipment, packaging, infrastructure, external, weather, etc.)
- The physical environment (e.g. residential, commercial, industrial, etc.)
- The road's appearance (e.g. flat, straight, inclined, curved, intersection, etc.)
- Timeline of event (e.g. how long it lasted, time of release or discovery, time of first responder arrival, etc.)
- Communications with first responders and with your organization

Photographs and diagrams should be submitted, as required, for clarification. Estimate the duration of the release, if possible. Please use additional sheets if necessary.

NOTE: Refer to the Guide for more information on how to complete this section

PART VI: INCIDENT DESCRIPTION – AIR ONLY

22. Please describe:

- Any serious jeopardy to persons on any aircraft or aircraft itself
- Any damages to property or environment
- The route by which the dangerous goods were to be or have been transported, including the name of any aerodromes along the route

Aircraft Operator

Air Cargo Facility



Hazardous Materials Incident Report

According to the Paperwork Reduction Act of 1995, no persons are required to respond to a collection of information unless it displays a valid OMB control number. The valid OMB control number for this information collection is 2137-0039. The filling out of this information is mandatory and will take 96 minutes to complete.

INSTRUCTIONS: Submit this report to the Information Systems Manager, U.S. Department of Transportation, Pipeline and Hazardous Materials Safety Administration, Office of Hazardous Materials Safety, DHM-63, Washington, D.C. 20590-0001. If space provided for any item is inadequate, use a separate sheet of paper, identifying the entry number being completed. Copies of this form and instructions can be obtained from the Office of Hazardous Materials Website at <http://hazmat.dot.gov>. If you have any questions, you can contact the Hazardous Materials Information Center at 1-800-HMR-4922 (1-800-467-4922) or online at <http://hazmat.dot.gov>.

PART I - REPORT TYPE

1. This is to report: **A) A hazardous material incident** **B) An undeclared shipment with no release**
 C) A specification cargo tank 1,000 gallons or greater containing any hazardous materials that (1) received structural damage to the lading retention system or damage that requires repair to a system intended to protect the lading retention system and (2) did not have a release.
2. Indicate whether this is: An initial report A supplemental (follow-up) report Additional Pages

PART II - GENERAL INCIDENT INFORMATION

3. Date of Incident: _____ 4. Time of Incident (use 24-hour time): _____
5. Enter National Response Center Report Number (if applicable): _____
6. If you submitted a report to another Federal DOT agency, enter the agency and report number: _____
7. Location of Incident: City: _____ County: _____ State: _____ ZIP Code (if known): _____
 Street Address/Mile Marker/Yardname/Airport/Body of Water/River Mile _____
8. Mode of Transportation Air Highway Rail Water
9. Transportation Phase In Transit Loading Unloading In Transit Storage
10. Carrier/Reporter Name _____
 Street _____
 City _____ State _____ ZIP Code _____
 Federal DOT ID Number _____ Hazmat Registration Number _____
11. Shipper/Offeror Name _____
 Street _____
 City _____ State _____ ZIP Code _____
 Waybill/Shipping Paper _____ Hazmat Registration Number _____
12. Origin (if different from shipper address) Street _____
 City _____ State _____ ZIP Code _____
13. Destination Street _____
 City _____ State _____ ZIP Code _____
14. Proper Shipping Name of Hazardous Material: _____
15. Technical/Trade Name: _____
- | | | | |
|---|---|--|--|
| 16. Hazardous Class/
Division: _____ | 17. Identification
Number: _____
(E.g. UN2764, NA 2020) | 18. Packing
Group: _____
(if applicable) | 19. Quantity
Released: _____
(Include Measurement Units) |
|---|---|--|--|
20. Was the material shipped as a hazardous waste? Yes No If yes, provide the EPA Manifest Number: _____
21. Is this a Toxic by Inhalation (TIH) material? Yes No If yes, provide the Hazard Zone: _____
22. Was the material shipped under an Exemption, Approval, or Competent Authority Certificate? Yes No
 If yes, provide the Exemption, Approval, or CA number: _____
23. Was this an undeclared hazardous materials shipment? Yes No

PART III - PACKAGING INFORMATION

24. Check Packaging Type (check only one - if more than one, list type of packaging, copy Part III, and complete for each type:

- Non-bulk IBC Cargo tank Motor Vehicle (CTMV) Tank Car
 Cylinder RAM Portable Tank Other _____

25. See instructions and enter the appropriate failure codes found at the end of the instructions. Be sure to enter the codes from the list that corresponds to the particular packaging type checked above. Enter the number of codes as appropriate to describe the incident. Enter the most important failure point in line 1. If there are more than two failure points, provide in this format in part VI.

1. What Failed: _____ How Failed: _____ Causes of Failure: _____
2. What Failed: _____ How Failed: _____ Causes of Failure: _____

26a. Provide the packaging identification markings, if available.

Identification Markings: _____

(Examples: 1A1/Y1.4/150/92/USA/RB/93/RL, UN31H1/Y0493/USA/M9339/10800/1200, DOT - 105A - 100W (RAIL), DOT 406 (HIGHWAY), DOT 51, DOT 3-A)

26b. For Non-bulk, IBC, or non-specification packaging, if identification markings are incomplete or unavailable, see instructions and complete the following:

Single Package or Outer Packaging:

Packaging Type: _____

Material of Construction: _____

Head Type (Drums only): Removable Non - Removable

Single Package or Inner Packaging (if any):

Packaging Type: _____

Material of Construction: _____

27. Describe the package capacity and the quantity:

Single Package or Outer Packaging:

Package Capacity: _____

Amount in Package: _____

Number in Shipment: _____

Number Failed: _____

Single Package or Inner Packaging (if any):

Package Capacity: _____

Amount in Package: _____

Number in Shipment: _____

Number Failed: _____

28. Provide packaging construction and test information, as appropriate:

Manufacturer: _____

Manufacture Date: _____

Serial Number: _____

Last Test Date: _____

Material of Construction: _____ (if Tank Car, CTMV, Portable Tank, or Cylinder)

Design Pressure: _____ (if Tank Car, CTMV, Portable Tank)

Shell Thickness: _____ (if Tank Car, CTMV, Portable Tank)

Head Thickness: _____ (if Tank Car, CTMV)

Service Pressure: _____ (if Cylinder)

If valve or device failed:

Type: _____ Manufacturer: _____ Model: _____
(if present and legible) (if present and legible)

29. If the packaging is for Radioactive Materials, complete the following:

Packaging Category: Type A Type B Type C Excepted Industrial

Packaging Certification: Self Certified U.S. Certification Certification Number _____

Nuclide(s) Present: _____ Transport Index: _____

Activity: _____ Critical Safety Index: _____

PART IV - CONSEQUENCES

30. Result of Incident (check all that apply): Spillage Fire Explosion Material Entered Waterway/Storm Sewer
 Vapor (Gas) Dispersion Environmental Damage No Release

31. Emergency Response : The following entities responded to the incident: (Check all that apply)
 Fire/EMS Report # _____ Police Report # _____ In-house cleanup Other Cleanup

32. Damages: Was the total damage cost more than \$500? Yes No
If yes, enter the following information: If no, go to question 33.
Material Loss: _____ Carrier Damage: _____ Property Damage: _____ Response Cost: _____ Remediation/Cleanup Cost: _____
\$ _____ \$ _____ \$ _____ \$ _____ \$ _____
(See damage definitions in the instructions)

33a. Did the hazardous material cause or contribute to a human fatality? Yes No
If yes, enter the number of fatalities resulting from the hazardous material:
Fatalities: _____ Employees _____ Responders _____ General Public _____

33b. Were there human fatalities that did not result from the hazardous material? Yes No If yes, how many? _____

34. Did the hazardous material cause or contribute to personal injury? Yes No
If yes, enter the number of injuries resulting from the hazardous material:
Hospitalized (Admitted Only): _____ Employees _____ Responders _____ General Public _____
Non-Hospitalized: _____ Employees _____ Responders _____ General Public _____
(e.g.: On site first aid or Emergency Room observation and release)

35. Did the hazardous material cause or contribute to an evacuation? Yes No
If yes, provide the following information:
Total number of general public evacuated _____ Total number of employees evacuated _____ Total Evacuated _____
Duration of the evacuation _____ (hours)

36. Was a major transportation artery or facility closed? Yes No If yes, how many? _____ (hours)

37. Was the material involved in a crash or derailment? Yes No
If yes, provide the following information: Estimated speed (mph): _____ Weather conditions: _____
Vehicle overturn? Yes No
Vehicle left roadway/track? Yes No

PART V - AIR INCIDENT INFORMATION (please refer to § 175.31 to report a discrepancy for air shipments)

38. Was the shipment on a passenger aircraft? Yes No
If yes, was it tendered as cargo, or as passenger baggage?
 Cargo Passenger baggage

39. Where did the incident occur (if unknown, check the appropriate box for the location where the incident was discovered)?
 Air carrier cargo facility Sort center Baggage area
 By surface to/from airport During flight During loading/unloading of aircraft

40. What phase(s) had the shipment already undergone prior to the incident? (Check all that apply)
 Shipment had not been transported Transported by air (first flight) Transport by air (subsequent flights)
 Initial transport by highway to cargo facility Transfer at sort center/cargo facility

PART VI - DESCRIPTION OF EVENTS & PACKAGE FAILURE

Describe the sequence of events that led to the incident and the actions taken at the time it was discovered. Describe the package failure, including the size and location of holes, cracks, etc. Photographs and diagrams should be submitted if needed for clarification. Estimate the duration of the release, if possible. Describe what was done to mitigate the effects of the release. Continue on additional sheets if necessary.

PART VII - RECOMMENDATIONS/ACTIONS TAKEN TO PREVENT RECURRENCE

Where you are able to do so, suggest or describe changes (such as additional training, use of better packaging, or improved operating procedures) to help prevent recurrence. Provide recommendations for improvement to hazardous materials transportation beyond the control of your individual company. Continue on additional sheets if necessary.

PART VIII- CONTACT INFORMATION

Contact's Name (Type or Print): _____ Telephone Number: () _____
Contact's Title: _____ Fax Number: () _____
Business Name and Address: _____ Hazmat Registration Number (if not already provided): _____
E-mail Address: _____ Date: _____
Preparer is: Carrier Shipper Facility Other _____



Weather and Natural Disasters

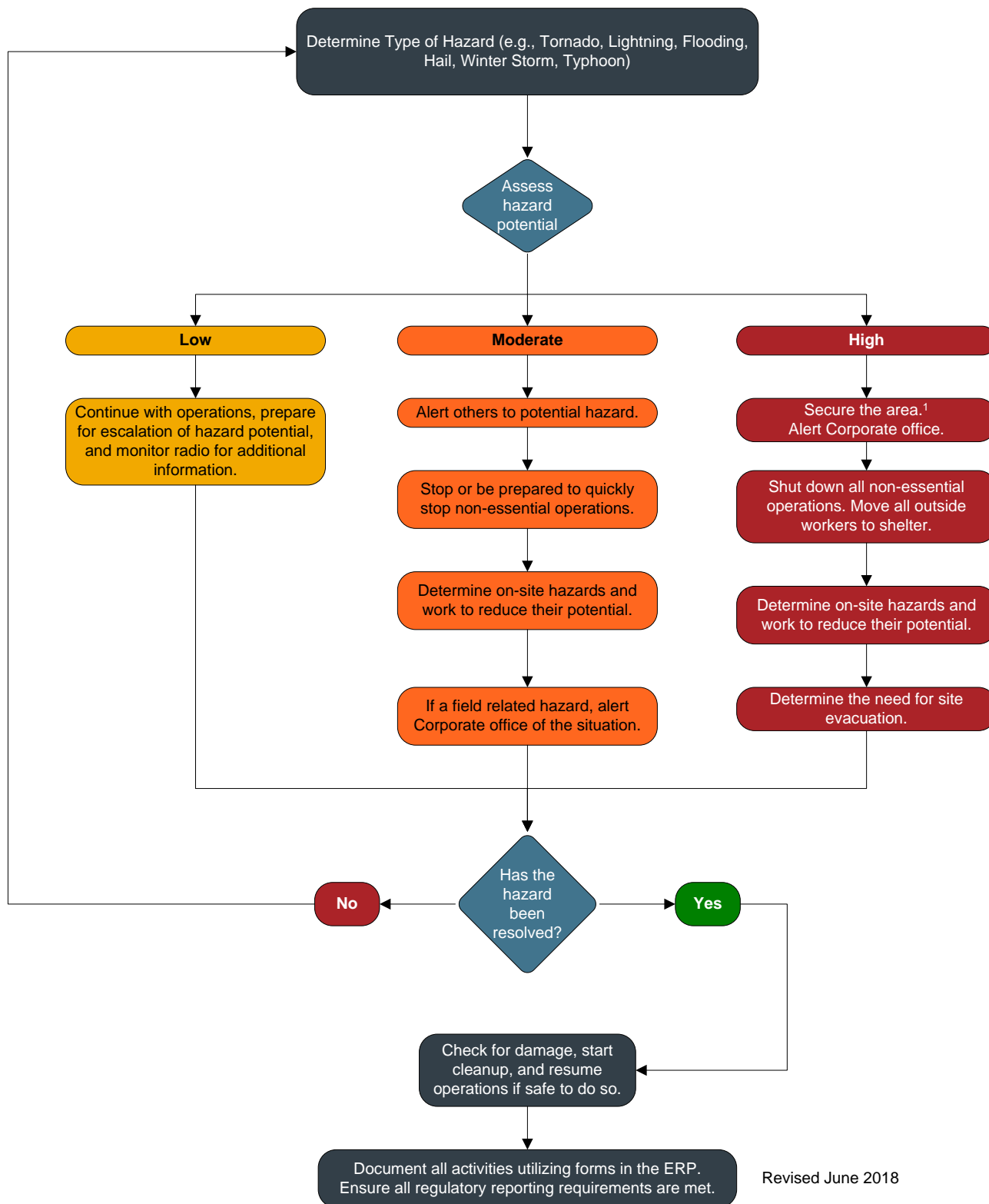

¹ The primary concern is for human life. If time allows and it is safe to do so, secure the area (tie down / secure objects that could be moved and cause additional damage).



Weather and Natural Disasters, continued

Severe storms can occur in Canada year round. In the months between May and September, hot and humid weather combined with a cold front could be a sign that a severe storm is brewing. A severe storm can create lightning, hail, severe rain fall (flooding), high winds and tornados. In the months between October and April, severe storms could include blizzards, freezing rain, heavy and blowing snow.

The weather office will issue through the use of radio and television repeated weather watches and warnings. The only exception to these warnings is earthquakes, since they occur by surprise and cannot be predicted.

Listen for the Warnings

Environment & Climate Change Canada (ECCC) monitors the weather 24-hours a day, seven days a week. If a severe storm is on the horizon, the weather service issues watches, advisories and warnings for that specific storm through national, regional and local radio and television stations, and through ECCC Weatheradio.

Weather Watch

This means conditions are favourable for a severe storm, even though nothing has developed yet. It does not mean that the storm will occur. A Weather Watch is usually issued early in the day; keep monitoring weather conditions and listen for updated statements.

Weather Warning

This means severe weather is happening or hazardous weather is highly probable. If the warning is for your area, take precautions immediately and listen to your radio for constant updates.

Earthquake

General Information

An earthquake (also known as a quake, tremor, or temblor) is caused by a sudden slip on a fault, which in turn, releases energy in waves that travel through rock to cause the shaking that we feel during an earthquake.

An earthquake cannot be prevented or predicted, but it can be mitigated. The effects of earthquakes include, but are not limited to, shaking and ground rupture. Most common effects or impacts of an earthquake are shaking and ground rupture. Depending on the magnitude of an earthquake, these may cause damage to buildings, pipelines and other rigid structures.

During an Earthquake

Be aware that some earthquakes are actually foreshocks and a larger earthquake might occur. Minimize movement to a few steps to a nearby safe place and stay indoors until the shaking has stopped and exiting is safe.



Weather and Natural Disasters, continued

If indoors

- DROP to the ground; take COVER by getting under a sturdy table or other piece of furniture; and HOLD ON until the shaking stops. If there isn't a table or desk near you, cover your face and head with your arms and crouch in an inside corner of the building.
- Stay away from glass, windows, outside doors and walls, and anything that could fall, such as lighting fixtures or furniture.
- Use a doorway for shelter only if it is in close proximity to you and if you know it is a strongly supported, load bearing doorway.
- Stay inside until shaking stops and it is safe to go outside. Research has shown that most injuries occur when people inside buildings attempt to move to a different location inside the building or try to leave.
- Be aware that the electricity may go out or the sprinkler systems or fire alarms may turn on.
- DO NOT use the elevators.

If outdoors

- Stay outdoors and move away from buildings, streetlights, and utility wires.
- Once in the open, stay there until the shaking stops. The greatest danger exists directly outside buildings, at exits, and alongside exterior walls. Ground movement during an earthquake is seldom the direct cause of death or injury. Most earthquake-related casualties result from collapsing walls, flying glass, and falling objects.

If in a moving vehicle

- Stop as quickly as safety permits and stay in the vehicle. Avoid stopping near or under buildings, trees, overpasses, and utility wires.
- Proceed cautiously once the earthquake has stopped. Avoid roads, bridges, or ramps that might have been damaged by the earthquake.

If trapped under debris

- Do not light a match.
- Do not move about or kick up dust. Cover your mouth with a handkerchief or clothing.
- Tap on a pipe or wall so rescuers can locate you. Use a whistle if one is available. Shout only as a last resort. Shouting can cause you to inhale dangerous amounts of dust.



Weather and Natural Disasters, continued

Floods

The potential for overland flooding can create a high level of risk for facility damage and environmental impact at petroleum facilities. While there is little that can be done to prevent flooding, actions can be taken to minimize the impact.

It is important to consider that your facility may play a vital role in fuel supply during an emergency situation. It is therefore important that you and the government authority having jurisdiction during a flood emergency have regular and clear communication with regards to facility closure.

To shut down a facility which may be flooded:

1. Take a product inventory reading of all underground and aboveground tanks, including water level readings.
2. Seal fill pipe caps to prevent water from entering underground tanks. Close all valves to above ground tanks. **DO NOT PLUG OR SEAL TANK VENT LINES.**
3. Underground tanks should be kept as full of product as possible. Above ground tanks should be filled to a level at least 25% above the estimated/predicted floodwater elevation.
4. Ensure that above ground tanks which could float away are secured or tethered in a manner that would prevent floating from the property.
5. Seal all drains in tank lots.
6. Oil/water separators and product sumps should be skimmed of product using sorbent pads or vacuum trucks as appropriate. Spent sorbent pads should be drummed and every effort must be made to remove any waste from the expected flood zone. If time does not allow for removal the drums must be secured to prevent them from floating away. Close the oil/water separator drain valve.
7. Drums and lubricant cubes should be tied down or otherwise secured to prevent floating.
8. Propane facilities - contact your propane supplier for appropriate flood emergency procedures.
9. Secure used oil collection cabinets. Every effort must be made to remove all waste oil from the expected flood zone. If waste oil from the cabinet drains to a waste oil underground tank, ensure the connection is tight.
10. Secure containers of chemicals, cleaning agents, pesticides, etc. Every effort must be made to remove these products from the expected flood zone. If they cannot be moved to a safe location, store these containers at high elevations in a manner that prevents them from floating off the property or leaking into floodwaters.
11. If the facility is to be closed/evacuated, shut down electrical power to the site at the main breaker. Contact the power service utility company to determine if the power service to the facility is going to be cut-off.
12. Shut down other utilities to the site including natural gas and potable water. If water is obtained from a water well, secure the well using a well seal.
13. Shut down all appliances, including hot water tanks, furnaces, etc.
14. Lock all doors and gates to the facility.
15. Post a sign in a prominent location identifying the names and telephone numbers where key company personnel can be contacted during the emergency.



Weather and Natural Disasters, continued

To start-up a facility which has been flooded:

1. Re-activate utilities to the site (natural gas, water, electricity) and appliances using qualified utility service personnel, where required.
2. Take product inventory readings and water dips of all tanks to determine if product has leaked out from the tanks or water has entered the tanks.
3. Take appropriate measures to test product quality.
4. Propane facilities – contact your propane supplier for recommissioning your propane facilities.
5. Pump out water from sumps and containment pans using a qualified petroleum contractor.
6. Follow all re-entry procedures and requirements for health and safety as provided by your local government authority (disinfection, potable water testing, etc.).

Government agencies monitor weather patterns, precipitation and provincial water levels and flows. They provide a comprehensive series of public advisories about potential flooding. These include river stage-up advisories, ice-jam warnings, high stream flow advisories, flood watches and flood warnings; for more information visit the following websites:

Alberta	Alberta Environment http://environment.alberta.ca/forecasting/advisories/
British Columbia	Ministry of Forests, Lands and Natural Resource Operations – River Forecast Centre http://bcrcfc.env.gov.bc.ca/warnings/index.htm
Manitoba	Government of Manitoba – Flood Information http://www.gov.mb.ca/flooding/index.html
Saskatchewan	Saskatchewan Watershed Authority https://www.wsask.ca/Lakes-and-Rivers/Stream-Flows-and-Lake-Levels/

What to do during a flood

- Gather essential items together in a high place.
- Collect things needed for evacuation.
- Stack sandbags, if possible, to form a barrier to hold back or redirect moving water from critical areas.
- Turn off gas, electricity and water supply if it is safe to do so.
- Avoid electricity sources.
- Avoid walking or driving through flood water.



Weather and Natural Disasters, continued

Thunderstorm and Lightning Safety

A lightning bolt carries up to 100 million volts of electricity. When someone is struck by lightning, an electrical shock occurs that can cause burns and even stop the person's breathing. Although thunder and lightning can occur occasionally during a snowstorm, April to October are the prime thunderstorm months in Canada. Thunderstorms occur most often in late afternoon or evening, and around sunrise.

Knowing how lightning behaves can help you plan for an approaching storm. It tends to strike higher ground and prominent objects, especially materials that are good conductors of electricity, such as metal. Thunder can be a good indicator of lightning - loud crackling means its close, whereas rumbling means the storm is further away.

Because light travels faster than sound, you will see lightning before you hear the thunder. Each second between the flash and the thunderclap represents about 300 metres. If you can hear thunder, you are within striking distance. Immediately go inside, there is NO safe place to be outside in a thunderstorm.

Protection from lightning begins before the storm. Paying attention to weather conditions and forecasts allows time to plan for threatening weather and to react appropriately.

What to do during a thunderstorm

The safest place to be during a thunderstorm is in a building that is fully enclosed with a roof, walls and floor with electrical wiring, plumbing, telephone line, or antennas to ground the lightning should the building be hit directly. Unsafe shelters are buildings or structures without electricity or plumbing to ground the lightning, as they do not provide any lightning protection. Shelters that are unsafe include covered picnic shelters, carports, tents, baseball dugouts as well as other small non-metal buildings (sheds and greenhouses).

Even when inside the building, there are safety precautions to take:

- Keep as many walls as possible between you and the outside. Stay away from doors, windows, and fireplaces.
- Stay away from anything that will conduct electricity such as radiators, stoves, sinks and metal pipes.
- Use battery operated appliances only. Avoid handling electrical appliances and regular telephones (cordless phones and cell phones do not increase the risk of a lightning strike).

The next best place for shelter is an enclosed metal car, truck or van but NOT a tractor, golf cart, topless or soft-top vehicle. Make sure the vehicle is not parked near trees or other tall objects that could fall over during a storm. When inside a vehicle during a lightning storm, roll up the windows and sit with your hands in your lap and wait out the storm. Don't touch any part of the metal frame or any wired device in the vehicle (including the steering wheel or plugged-in cell phone). A direct strike to your car will flow through the frame of the vehicle and usually jump over or through the tires to reach ground.

What to do if you cannot find shelter

There is no safe place to be outdoors during a thunderstorm. However, to reduce the risk of being struck by lightning when outside, stay away from things that are tall (trees, flagpoles or posts), water, and other objects that conduct electricity (tractors, metal fences, lawn mowers, golf clubs). Do not become a target by being the highest object on the landscape. If you are with a group of people in the open, spread out several metres apart from one another.

If you get caught in a level field far from shelter, crouch down on the balls of your feet immediately, with feet together, place your arms around your knees and bend forward. Be the smallest target possible, and at the same time, minimize your contact with the ground. Don't lie flat.



Weather and Natural Disasters, continued

If someone has been hit by lightning

Lightning victims are safe to touch. Bystanders shouldn't hesitate to save a life by calling for help. If breathing has stopped, administer mouth-to-mouth resuscitation. If the victim is not breathing or they do not have a pulse, a trained rescuer should administer cardiopulmonary resuscitation (CPR).

Tornados

A tornado is nature's most violent form of storm activity. It can produce upwardly spiraling winds of 120 to 450 km/h, producing devastating damage along a path of 50 to 300 metres in width. The forward motion of the tornado funnel may be quite erratic as it zigzags along a southwest to north-easterly direction (usually) at a forward speed of 50 to 70 km/h.

Hot, humid weather combined with a cold front could be a sign that a tornado is brewing, and a funnel cloud hanging from a dark cloud may be visible before the tornado actually occurs (a funnel cloud is not a tornado until it touches the ground). The sound has been described as a tremendous roar which sounds like an express train or jet aircraft (only louder). Clouds may be green or yellow tinged. There is usually a noticeable lowering of a portion of the cloud that contains a large, swirling, turbulent mass from which the funnel will hang (funnel cloud).

Protecting yourself during a tornado

- Have a radio on to listen for warning information or advice.
- Determine an appropriate shelter (select a shelter area that would offer protection, such as underneath a stairway and is secured to the main floor). The shelter must be easily accessible and able to offer protection from flying glass, debris and furniture. (Decide on shelter options in advance, for your place of employment.) If forced to take shelter away from the plant avoid large halls or any large building with large span roofs. Seek out an inner hallway, washroom, closet, etc.
- Stay away from windows.
- Avoid travelling any great distance so that you will not be caught out in the open.
- If the storm warning is issued for your immediate area, go to your designated shelter.
- If caught outdoors and you cannot reach shelter, lie flat in a ditch, excavation or culvert. If possible, lay flat, holding the base of a small tree, bush or shrubbery to avoid being lifted or blown away.
- If caught while driving, drive away from the funnel at a right angle or to its direction of travel (if possible). If you cannot escape the path of the funnel, get out of your vehicle immediately and seek shelter in a ditch or ravine, keeping its slope between you and the funnel.
- If caught away from the plant, seek shelter in a sturdy building. Go to an interior hallway or washroom on the lower floor, and stay away from windows.

Winter Storms: Blizzards, Freezing Rain, Heavy Snow, Blowing Snow

General Information

Blizzards come in on a wave of cold arctic air, bringing snow, bitter cold, high winds, and poor visibility in blowing snow. These conditions must last for a minimum of six hours to be designated a blizzard and they may last for several days. Poor visibility, low temperatures and high winds constitute a significant hazard.



Weather and Natural Disasters, continued

Freezing rain occurs when the air in an upper-air layer has an above-freezing temperature, while the temperature at the surface is below freezing. The snow that falls melts in the warmer layer; as a result, it is rain—not snow—that lands on the surface. But since the temperature is below 0°C, raindrops freeze on contact and turn into a smooth layer of ice. More slippery than snow, freezing rain is tough and clings to everything it touches. A bit of freezing rain is dangerous; a great deal of it can be catastrophic.

Things to do during a severe winter storm or if a storm is forecast

- Stay calm and leave your radio on to stay informed of the situation and hear updated forecasts.
- Stay indoors. If you must go out, dress for the weather.
- Secure everything that might be blown around or torn loose – indoors and outdoors (flying objects can injure people and damage property).
- If you are outdoors when a storm hits, take shelter immediately.

Winter Weather Warnings	Issued
Blizzard Warning	When winds of 40 km/hr or greater are expected to cause widespread reductions in visibility to 400 metres or less, due to blowing snow, or blowing snow in combination with falling snow, for at least 4 hours.
Freezing Rain Warning	When freezing rain is expected to pose a hazard to transportation or property; or when freezing rain is expected for at least 2 hours.
Snowfall Warning	When 10 cm or more of snow is expected to fall within 12 hours.
Wind Warning	70 km/h or more sustained wind; and/or Gusts to 90 km/h or more.
Wind Chill Warning	Issued to warn of conditions that will cause frostbite to exposed skin. Criteria vary across the country, ranging from wind chill values of -55 in some Arctic regions to -30 in South-western Ontario. A national wind chill program is in development. For wind chill values: -27 to -44 ...risk of frostbite and risk of hypothermia increases with time spent outdoors -45 or lower ...exposed flesh may freeze in minutes and there is a serious risk of hypothermia
Winter Storm Warning	When severe and potentially dangerous winter weather conditions are expected, including: A major snowfall (25 cm or more within a 24 hour period); and A significant snowfall (snowfall warning criteria amounts) combined with other cold weather precipitation types such as: freezing rain, strong winds, blowing snow and/or extreme wind chill.

Source: Environment & Climate Change Canada (ECCC), Public Alert Criteria

<http://www.ec.gc.ca/meteo-weather/default.asp?lang=En&n=D9553AB5-1>



Weather and Natural Disasters, continued

After a Disaster

These are general guidelines to look for after an occurrence:

- Assess site and declare an emergency as required.
- Activate ERP as required.
- Account for all on-site and field personnel.
- Listen to a battery-operated radio or television for the latest emergency information.
- Give first aid to the injured and call for medical assistance if required. Do not move seriously injured persons unless they are in immediate danger of further injury. Use intrinsically safe flashlights to survey for damage and look for victims. Do not use candles or matches (explosion hazards may exist).
- Use the telephone for emergency calls only.
- Check for spilled medicines, bleaches, gasoline or other flammable liquids.
- Open cabinets cautiously. Beware of objects that can fall off shelves.
- Report fires to the fire department. Be alert to prevent fires, as broken water mains may cause a reduction in water pressure. Lightning and downed power lines can cause fires. Know how to fight small fires.
- Inspect utilities.
 - Look for electrical system damage. If you see sparks or broken or frayed wires, or if you smell hot insulation, turn off the electricity at the main fuse box or circuit breaker. Do not go near loose or dangling power lines. If you have to step in water to get to the fuse box or circuit breaker, call an electrician first for advice.
 - Check for sewage and water lines damage. If you suspect sewage lines are damaged, avoid using the toilets and call a plumber. If water pipes are damaged, contact the water company and avoid using water from the tap. You can obtain safe water by melting ice cubes.
 - Check for leaking pipes. If you smell sour gas:
 - Immediately evacuate the area and don appropriate personal protective equipment.
 - Close gas valves and isolate the area.
 - Turn off the main power switch (only if you are NOT wet or standing in water).
 - Shut down required plant and well sites and notify appropriate government authorities.
 - Check buildings prior to entering as there may be structural damage; proceed cautiously.
- In the case of a flood, proper cleanup is essential. Discard all materials that cannot or should not be saved. Wash and rinse all surfaces, then disinfect them. Remove any water as soon as possible and clean out mud and other debris. Water supplies may be contaminated; use caution with drinking water.
- In the case of an earthquake, expect aftershocks. These are usually less violent than the main quake but can be strong enough to do additional damage to weakened structures and can occur in the first hours, days, weeks, or even months after the quake.

Note: The emotional impacts of disasters on those affected can be distressing and lasting, even if it doesn't involve physical harm. Help by maintaining a positive attitude and a sense of calmness. Your local health authority can assist in coping with trauma resulting from a disaster.



Security Incidents

A security incident is a security-related occurrence, threat or action that has adversely affected people, the environment, assets and economic stability, or could potentially do the same.

General Notes on Prevention of Security Incidents

As defined in the CSA Standard Security Management for Petroleum and Natural Gas Industry Systems (Z246.1-17), a Security Management Program should be implemented to ensure security incidents and threats are identified and managed with appropriate safeguards and response procedures in place.

This documented security risk management process should incorporate threat, vulnerability, risk assessment and asset characterization. Asset characterization, in particular, identifies and ranks any assets that could result in adverse consequences if damaged or destroyed.

To minimize the possibility of threats within a company property, an adequate physical security system must be in place. This should include the following:

- Perimeter fencing and gates to protect against unauthorized entry into a facility – gates should be closed when not in use and locked when unoccupied
- Appropriate signage at the perimeter and entrances
- Intrusion detection systems / alarm systems
- Sufficient lighting in darkness or areas of poor visibility
- Pedestrian access control
- Security guard force, both static and mobile
- Employee awareness

Types of Security Threats

Security-related threats have the intent to cause harm and could include bomb threats, suspicious packages, terrorism, vandalism, trespassing and cyber-attacks.

Responding to Threats

Should any facility or office be the subject of a threat, or be advised of the potential of a terrorist attack, or of the potential of an attack to an adjoining facility being operated by another company, the person receiving the initial threat should remain calm, document all information in writing and notify his supervisor immediately. The supervisor should make an immediate assessment of the circumstances then:

- Obtain all data from the person who received the threat.
- If there is clear and imminent danger, the plant should be immediately evacuated, and the Field Response Team activated from a remote location.
- Contact local police / Royal Canadian Mounted Police (RCMP).
- Notify the Regulatory Agency and the EOC Director.



Security Incidents, continued

Once the Field Response Team is activated, the Field Response Team Incident Commander and a senior company representative will consider the threat and options available to respond to the threat. There are a myriad of potential short and long term responses available and they will be dependent on the evaluation of the threat, time available to respond, resources available locally or that can be brought in a reasonable time, and police and military resources available.

- If the threat is considered possible, the Canadian Security Advisor recommends that the following immediate/short term responses should be considered:

Field Operations:

- Establish intelligence liaison with local authorities (e.g. police).
- Report all suspicious activity to Corporate Security.
- Discontinue all site tours and visits.
- Restrict vehicle access to specifically authorized vehicles only.
- ID all visitors seeking access.
- Assign a person to patrol the perimeter of the facility at the beginning of each operational shift and note any deficiencies; look for signs of attempted break and enter.
- Conduct an evacuation exercise.

Remotely Operated Facilities (also applies to any facility operated by a single person):

- Establish full lock down on fences and assets on the lease/site – everything that can be secured and locked is secured and locked.
- Conduct a fence perimeter patrol before entering the site – look for signs of illegal entrance.
- Conduct a full exterior building patrol before entering a building – look for signs of unlawful entrance (doors pried, windows open, broken glass etc.).
- When working, lock the gates upon entering and leaving the facility, and rigidly adhere to the work alone guidelines.

Bomb Threats

Bomb threats are delivered in a variety of ways. The majority of threats are called in to the target, though occasionally these calls are through a third party. Sometimes a threat is communicated in writing, or by a recording.

Persons making bomb threats generally have one of two motivations:

1. The caller has definite knowledge or believes that an explosive or incendiary bomb has been, or will be, placed. He or she wants to minimize personal injury or property damage. The caller may be the person who placed the device or someone who has become aware of such information.
2. The caller wants to create an atmosphere of anxiety and panic which will, in turn, result in a disruption of the normal activities at the location where the device is purportedly placed.

While most bomb threats are unfounded, some are not. As such, each one must be dealt with as though it is real and handled seriously and calmly.



Security Incidents, continued

Bomb Appearance

Bombs can be constructed to look like almost anything, and can be placed or delivered in any number of ways. The probability of finding a bomb that looks like the stereotypical bomb is almost non-existent. Most bombs are homemade, and are limited in their design only by the imagination and resources available to the bomber.

Remember, when searching for a bomb, suspect anything that looks unusual. Ultimately, however, let a trained bomb technician determine what is or is not a bomb.

Responding to Bomb Threats over the Phone

Most threats or implied threats are received by telephone, generally at a publicized or switchboard number. Should that occur, obtain as much information as possible, filling out the Threatening Call / Bomb Threat form (**Section 6: Forms**).

If a bomb threat is received over the telephone, the employee receiving the phone call should take the following actions:

- Stay calm and keep their voice calm.
- Pay close attention to details. Write information down as the caller says it. Attempt to get the following information from the caller:
 - What type of bomb is being used?
 - Did you place the bomb?
 - Who is the target?
 - Where has the bomb been placed?
 - What time is the bomb set to explode?
 - Why was the bomb placed?
 - What type of container is the bomb placed in?
 - What does it look like?
 - What is the bomber's name?
 - What is the bomber's address?
- While the first employee is dealing with the threatening phone call, they should have a co-worker or another person contact the police (dial 911) using another telephone, and as covertly as possible. As the first employee writes down answers to the questions above, these answers should be relayed to the police.
- The call recipient should attempt to keep the caller on the phone.
- The call recipient should note the caller's:
 - Age and gender
 - Emotional state (angry, agitated, calm, etc.)
 - Speech patterns (accent, tone)
 - Background noise (traffic, people talking and accents, music and type, etc.)

Responding to Bomb Threats Received in Writing

If a threat has been received in writing, minimize the handling of the document to ensure preservation of forensic evidence - DO NOT PHOTOCOPY.



Security Incidents, continued

Supervisor Responsibilities after Receiving a Bomb Threat

The supervisor should then:

- Obtain all data from the person who received the threat
- Activate the ERP if the situation warrants
- Contact local police / Royal Canadian Mounted Police (RCMP) if this has not already been done
- Notify the Regulatory Agency
- Decide on partial or total evacuation (if needed)
- Decide on partial or total search of the facility (if needed)

Evacuating the Facility

If it seems prudent to evacuate the building:

- Have all employees briefly check their work areas for unfamiliar items.
- Instruct all employees not to touch suspicious items, but simply to report them to their supervisors (taking pictures if feasible).
- Instruct all employees not to take personal belongings when they leave.
- Leave doors and windows open
- Do not to turn light switches on or off.
- Do not activate the fire alarm.
- Use stairs only; do not use elevators.
- Use of radio communications should be restricted as the signal could detonate a device.
- All evacuees should report to an outside pre-designated muster area for accountability.

IED Evacuation Distances

Improvised Explosive Device (IED)
SAFE STAND OFF DISTANCE

	Threat Description	Explosives Mass (TNT equivalent) ¹		Building Evacuation Distance ²		Outdoor Evacuation Distance ³	
High Explosives (TNT Equivalent)	Pipe Bomb	5 lbs	2.3 kg	70 ft	21 m	850 ft	259 m
	Suicide Belt	10 lbs	4.5 kg	90 ft	27 m	1,080 ft	330 m
	Suicide Vest	20 lbs	9 kg	110 ft	34 m	1,360 ft	415 m
	Briefcase/Suitcase Bomb	50 lbs	23 kg	150 ft	46 m	1,850 ft	564 m
	Compact Sedan	500 lbs	227 kg	320 ft	98 m	1,500 ft	457 m
	Sedan	1,000 lbs	454 kg	400 ft	122 m	1,750 ft	534 m
	Passenger/Cargo Van	4,000 lbs	1 814 kg	640 ft	195 m	2,750 ft	838 m
	Small Moving Van/ Delivery Truck	10,000 lbs	4 536 kg	860 ft	263 m	3,750 ft	1 143 m
	Moving Van/Water Truck	30,000 lbs	13 608 kg	1,240 ft	375 m	6,500 ft	1 982 m
	Semitrailer	60,000 lbs	27 216 kg	1,570 ft	475 m	7,000 ft	2 134 m



Security Incidents, continued

Bomb Search Guidelines

Employees must not touch anything - only law enforcement explosive disposal units or qualified private consultants are qualified to search for a bomb or suspicious package.

In the event of a search, however, employees may be called upon to unlock drawers, cabinets, and the like for the search crew, and to identify any strange or unfamiliar objects.

Explosive Device Located

If a device or suspected device is located:

- Do not touch or move the object.
- Evacuate the immediate area.
- If possible, take steps to minimize effects of an explosion in the vicinity by evacuation or isolation of the area.
- Ensure RCMP are apprised of the location so explosive disposal unit can be called.

If there is an Explosion

- Have employees take cover under sturdy furniture, or leave the building if directed to do so by emergency responders.
- Stay away from windows.
- Do not light matches.
- Move well away from the site of the hazard to a safe location.
- Use stairs only; do not use elevators.
- Call 911 if no one has called.

Suspicious Packages

The likelihood of receiving a bomb in the mail is remote. Unfortunately, however, a small number of explosive devices have been mailed over the years resulting in death, injury and destruction of property.

A bomb can be enclosed in either a parcel or an envelope, and its outward appearance is limited only by the imagination of the sender. However, mail bombs have unique characteristics that may assist in identifying suspect packages.



Security Incidents, continued

Appearance of Suspicious Packages

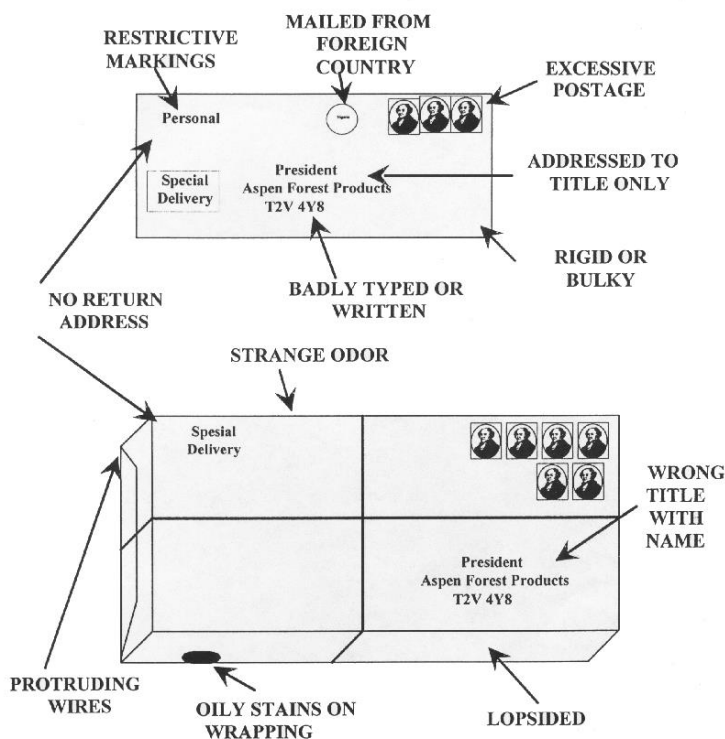

- Mail bombs may display restricted endorsements such as “Personal” or “Private”. This factor is important when the addressee does not usually receive personal mail.
- Addressee’s name / title may be inaccurate.
- Return address may be fictitious.
- Mail bombs may reflect / distort handwriting or the name and address may be prepared with homemade labels or cut-and-paste lettering.
- Cancellation or postmark may show a different location than the return address.
- Mail bombs may have excessive postage.
- Mail bombs may feel rigid or appear uneven or lopsided and may have an irregular shape, soft spots or bulges.
- Parcel bombs may be unprofessionally wrapped with several combinations of tape used to secure the package and may be endorsed “Fragile – Handle With Care” or “Rush – Do Not Delay”.
- Parcel bombs may have a buzzing or ticking noise or a sloshing sound.
- Pressure or resistance may be noted when removing contents from an envelope or parcel.



Security Incidents, continued

Dealing with Suspicious Packages

If an employee is suspicious of a mailing and is unable to verify the contents with the addressee or sender:

- Do not open the article.
- Isolate the item and evacuate the immediate area.
- Do not put the package or envelope in water or a confined space such as a desk drawer or filing cabinet.
- If possible, open windows in the immediate area to assist in venting potential explosive gases.

If an employee suspects a harmful chemical or biological substance is in a package already on company property they should:

- Cover the package or envelope with a plastic sheet, raincoat, etc.
- Evacuate the room closing all doors and windows.
- Call their supervisor who will contact the local police.
- Isolate the area where the package is.
- Isolate themselves in another area that has a telephone and wait for the emergency responders to arrive.

If an employee has touched a package that possibly contains a harmful substance or got some on their clothes, they should:

- Wash their hands well.
- Shower with their clothes on
- Undress and seal their clothes in a plastic bag.
- Shower again and put on fresh clothes.

If an employee has any reason to believe a letter or parcel is suspicious, they should never take a chance or worry about possible embarrassment if the item turns out to be innocent.

Trespassing

Any person who enters land where entry is prohibited or does not leave land immediately after being directed to do so by the owner or occupier of the land is guilty of trespassing.

Dealing with Trespassing

If any personnel encounter a trespasser:

- Ask the trespasser to leave the unauthorized area.
- Give the trespasser a reasonable amount of time to leave peacefully.
- If the trespasser refuses to leave, call the RCMP / local authority.



Security Incidents, continued

Vandalism

Vandalism is the willful damaging or defacing of property belonging to another person or to the public. Acts of vandalism can include:

- **Defacing** – removing, marking or damaging a part of an object to draw attention to it.
- **Criminal damage** – willful and unlawful destruction of other people's property.
- **"Tagging" or graffiti** – gangs use "tags" to mark their territory and usually spray-paint walls and doors of homes and business establishments.

Vandalism can happen at any time of the day or night and in any season, but it most often occurs:

- In the evening during summer and fall
- On weekday evenings
- At night when fewer people are around and the property isn't under as much scrutiny
- Where building design and lighting offers concealment and anonymity
- In areas frequented by young people such as schools, parks, shopping plazas and public buildings
- In unoccupied buildings, open spaces or parked vehicles where minimum surveillance is given to property

Dealing with Vandalism

- Report all incidents of vandalism to a supervisor
- Do not paint over vandalism and graffiti until the police department gives clearance to do so.

Terrorism

Terrorism is the use of violence and threats against persons or property for the purposes of intimidation, coercion or ransom. The direct targets of violence are not the main targets of a terrorist but a means to draw the attention of the local populace, the government and the world to their cause. A terrorist group commits acts of violence to:

- Produce widespread fear
- Obtain worldwide, national, or local recognition for their cause by attracting the attention of the media
- Destroy facilities or disrupt lines of communication in order to create doubt that the government can provide for and protect its citizens
- Discourage foreign investments, tourism or assistance programs that can affect the target country's economy and support of the government in power
- Influence government decisions, legislation or other critical decisions
- Satisfy vengeance

Acts of terrorism include threats of terrorism, assassinations, kidnappings, hijackings, bomb scares and bombings, cyber-attacks, and the use of chemical, biological, nuclear and radiological weapons.



Security Incidents, continued

Examples of Petroleum Assets Subject to Risk

- Buildings: Administration offices, corporate offices, control rooms
- Equipment: Process units and associated control systems, product storage tanks, surge vessels, boilers, turbines, process heaters, sewer systems
- Support Systems: Utilities such as natural gas lines, electrical power grid and facilities (including back-up power systems), water-supply systems, wastewater treatment facilities
- Transportation Interfaces: Railroad lines and railcars, product loading racks and vehicles, pipelines entering and leaving facility, marine vessels and dock area, off-site storage areas
- Cyber systems and information technology: Computer systems, networks, all devices with remote maintenance ports, SCADA systems, laptops, PDAs and cell phones.

Dealing with Terrorism

All threats and incidents should be reported to the RCMP Terrorism Tip Line at 1-800-420-5805.

In order to deal with threats of terrorism, it is important to establish a security management system to effectively manage security risks. This system should include a security risk management process incorporating asset characterization, threat assessment, vulnerability assessment, risk assessment, risk mitigation, communication and recommendations.

This system should be reviewed at regular intervals and updated as necessary.

Cyber-Attacks

Cyber-attacks are computer-to-computer attacks that undermine confidentiality, integrity or availability of a computer or the information contained.

Cyber-attacks can make computer systems malfunction or result in a disrupted flow of data and have the potential to create extreme economic damage.

This threat includes a risk to SCADA and DCS systems, which collect, display and store information in support of controlling equipment, devices and facilities.

Preventing Cyber-Attacks

Steps that can be taken to enhance your cyber security:

- Know who owns and operates the IT system and its operating framework.
- Map the network – include all internal/external connections, configuration control, etc.
- Develop a security policy structure and implement compliance monitoring.
- Apply as much security and hardening as appropriate.
- Accredite the IT system and follow a risk management approach.
- Know the system's possible vulnerabilities.
- Patch the system in a timely manner – the longer this is delayed, the longer the system is vulnerable.
- Reduce Internet access points.
- Reduce or eliminate potential sources of infection – USB flash drives (thumb drives, USB keys, etc.), flash media, etc.



Security Incidents, continued

- Communicate, train and educate staff and users.

Source: 10 IT Security "Commandments" - Communications Security Establishment Canada

Dealing with Cyber-Attacks

In the event of a cyber-incident:

- After obtaining corporate approval, local police or RCMP should be notified.

Serious cyber incidents:

- Should be reported to Public Safety Canada by email at contact@cyber.gc.ca or by phone at 1-833-292-3788.



Animal Encounters

First Responders to Animal Attacks

In the event of witnessing or identifying a scene as an attack, it is important to avoid harm to yourself. If equipped with deterrents, an attempt to scare away any remaining animals on scene is optional. In most cases any animals who have recently engaged in an attack are unpredictable therefore it is advised to keep clear and wait until the scene is clear. Steps to be considered:

- Assess the immediate area for personal safety and determine the type of incident
- If cause of injury is unknown, use your gas monitor to ensure there aren't any air-borne hazards.
- Ensure all animals have vacated the scene.
- If not, use any available noise deterrents (Honk Horn, Rev Engine, yell etc.)
- If possible call or radio for assistance and emergency services.
- Calling an applicable wildlife agency is an effective alternative; however, if confronted with a fast paced scenario such as this, the RCMP will be able to direct your call appropriately.
- Once the area is safe, assess the individuals' injuries and administer any necessary first aid. If the victim is conscious, always ask for his/her consent before doing so.
- Stay with the victim until help arrives:
 - As shock to the victim may be a factor after an attack, using a calm voice and catering to the individuals' requests as best possible is beneficial. For example; covering the victim with a blanket, providing drinking water for the victim, ensuring the victim that help is on the way, etc.
 - Minimize the victim's movements until emergency services have arrived as the extent of harm to the individual is unknown until assessed by a licensed health care representative.
- It is important to document the time and actions taken if a scenario like this presents itself as it will aid you and your company in showing what actions have been taken and how the situation has been responded to.
- Notify your supervisor of the incident.
- You or your supervisor must contact the applicable wildlife regulatory agency to report the incident.



Animal Encounters, continued

Bears

There are no hard and fast rules about what to do when you confront a bear. Bears react to humans in different ways in different situations. A bear's reaction depends on the following: sex, age, health; the season; whether the bear is hungry; whether bear cubs are present or whether there is an escape route available to the bear. Never harass or chase a bear!

There are three possible scenarios that are most likely to occur:

1. **A wandering bear.** While it is unlikely that a bear will wander into an area and near workers, we must be prepared to deal with this situation. Any bear seen on the job site will cause an immediate notification of the Incident Commander. In addition, all workers within 500 metres of the animal are to seek immediate shelter within a vehicle or building. The Incident Commander shall assess the situation, observe the bear for its intent, and determine a proper course of action to be taken. At no time will the bear be approached by any workers for any reason other than at the direction of the Incident Commander.
2. **A located occupied den.** A den occupied by a bear will cause an immediate cessation of work and removal of personnel within 500 metres of the den and notification of the Incident Commander. At the discretion of the Incident Commander, the appropriate Environment Fish and Wildlife agency may be notified to determine the best course of action to be taken.
3. **Denning bear disturbed.** The company understands that disturbing a hibernating bear is unsuitable for both the bear and for the workers. Upon discovery or disturbance of a hibernating bear all workers will immediately retreat from the area to a distance of not less than 500 metres and into immediate shelter within a vehicle or building. This situation will cause an immediate notification of the Incident Commander.

On the Trail

Bear encounters on the trail can be dangerous, especially if the bear is surprised or if it is a female with cubs. The bear may consider you a threat and either run away or attempt to remove you as a threat. If you encounter a bear on a trail:

- Stop! Try to stay calm and quiet. Do not make any sudden moves or loud noises. Avoid direct eye contact with the bear; however, never take your eyes off the bear.
- Size up the situation. Is it a black bear or a grizzly? Are there cubs present and where are they in relation to you and the bear? Did you disturb the bear during feeding? Where is the rest of your party? (Always stay together as a group; a bear is less likely to attack a group of people than an individual).
- Do not run from the bear. You cannot out run it! Black bears can reach speeds of 55km/hr.
- Talk quietly and slowly back up leaving the way you came; give the bear enough time and room to leave on its own. Invading the bears space will invoke its "fight or flight" response. Grizzly bears are most likely to fight while Black bears are most likely to choose flight. Avoid any rapid movements and move up wind so the bear can catch your scent and determine you are not a threat.
- If the bear keeps coming at you, climb the tree as high as you can. Remember, some grizzlies and all black bears can climb trees; but if you climb a tree the bear may feel less threatened.



Animal Encounters, continued

In Case of Attack (general)

Try to defend yourself on a steep slope or grade; in doing so, you can ensure that any bear will at least have a difficult time standing erect, thereby reducing his full weight force. Bears are also front-heavy, creating an offset in balance when downing slopes or grades.

- Do not run from the bear. You cannot out run it. A bear will often make a "bluff" charge, in which it turns away at the last moment. Running away from such a charge will trigger a more aggressive attack.
- If the bear continues the attack, spray bear ("pepper") aerosol in the animal's eyes. This may cause the bear to stop the attack, and give you an opportunity to escape.

Note: Bear spray must be kept on your person within easy reach or it will not be of use. Bear spray is not a repellent, but a weapon that is only effective in the animal's eyes and nose. It will not repel bears from a sprayed area. In fact, there is evidence to suggest that bears are attracted to objects covered with pepper spray. Read the instructions, understand how to use the spray, and test it to be sure of its range and accuracy.

- If no escape is possible and the bear has knocked you to the ground—roll yourself into a "cannonball" position and play dead. Cover your neck and head with your hands and arms. Stay in this tucked position until the bear leaves.
- If a black bear is attacking you, or you are attacked at night by either species, consider it a predatory attack and fight back with everything you have.

Defensive Attack

- Bears will engage in a defensive attack when feeling threatened or cornered. This type of attack occurs when a bear is protecting her young, or the carcass of its latest kill. The bear will show signs of stress, like huffing, pawing the ground, exposing its teeth, body swaying and pinning its ears back. The bear in this type of attack will often make "bluff" charge, in which it will turn away at the last moment or veer off its path.
- In this type of attack, play dead to show the bear you are not a threat.
 - If wearing a pack, leave it on for protection
 - Lie face down on the ground, legs splayed (spread) so the bear cannot easily turn you over
 - If rolled over, quickly turn back onto stomach
 - Clasp hands around the back of your neck
 - Do not shout or act aggressive
 - Remain quiet and still
 - Be prepared to wait until the bear realizes you are not a threat.
- If the bear continues to attack, fight for your life, aiming your assault at the bears head, nose and eyes.

Predatory attack

- Bears will show no signs of stress during this type of attack. The bear will stalk you and swiftly attack without a warning or "bluff" charge.
- In this type of attack, act aggressive to show the bear you will not be easy prey
 - Do not be submissive
 - Face the bear, never taking your eyes off of it



Animal Encounters, continued

- Don't attempt to run away
 - Scan for any near-by cover and possible weapons (stick and stones)
 - Prepare your deterrent
 - Make yourself as large as possible
 - Raise your arms and stomp your feet
 - Use rapid arm and leg movement
 - Shout loudly
 - Remove your pack
 - DO NOT PLAY DEAD
- If the bear continues to attack, fight for your life, aiming your assault at the bears head, nose and eyes.

In Camp

Bears entering a camp may be coming to feed on human food and garbage, based on their past experiences in camps. Such bears are especially dangerous because they have become human habituated and no longer fear people. It is important if a bear wanders into your campsite to provide it with a negative stimulus to prevent it from returning and becoming human habituated (screaming, noise deterrents etc.). If your campsite is clean, with all attractants properly stored, a bear may lose interest and move on. If a bear comes into your camp, refer to the points in ON THE TRAIL. If your vehicle is nearby, get in it as soon as possible.

Cougars

Conflict between cougars and humans is extremely rare. Although a cougar attack is highly unlikely, it always pays to be prepared. Information and awareness are your best defenses.

- Cougars are most active at dusk and dawn. However, they will roam and hunt at any time of the day or night and in all seasons.
- During late spring and summer, one to two-year old cougars become independent of their mothers. While attempting to find a home range, these young cougars may roam widely in search of unoccupied territory. This is when cougars are most likely to conflict with humans.
- Cougars have four toes with three distinct lobes present at the base of the pad. Claws are retractable, so they usually do not leave imprints.
- Generally, cougars are solitary. If tracks show two or more cougars traveling together, it probably indicates a female with cubs.
- Cougars seem to be attracted to children, possibly because their high-pitched voices, small size, and erratic movements make it difficult for cougars to identify them as human and not as prey.

Cougar Safety

- Avoidance is the best line of defense.
- Keep a radio playing.
- Do not attract or feed wildlife, especially deer or raccoons. These are natural prey and may attract cougars.
- Roaming pets are easy prey.



Animal Encounters, continued

- Bring pets in at night. If they must be left out, confine them in a kennel with a secure top.
- Do not feed pets outside. This not only attracts young cougars but also many small animals, such as mice and raccoons, that cougars prey upon.
- Place domestic livestock in an enclosed shed or barn at night.
- Hike in groups of two or more. Make enough noise to prevent surprising a cougar.
- Carry a sturdy walking stick to be used as a weapon.
- Watch for cougar tracks and signs. Cougars cover unconsumed portions of their kills with soil and leaf litter. Avoid these food caches.
- Cougar cubs are usually well hidden. However, if you do stumble upon cougar cubs, do not approach or attempt to pick them up. Leave the area immediately, as a female will defend her young.

If You Meet a Cougar

- All cougar encounters should be considered predatory. Act big and confident. Make direct eye contact, be loud and attempt to intimidate.
- Never approach a cougar. Although cougars will normally avoid a confrontation, all cougars are unpredictable. Cougars feeding on a kill may be dangerous.
- Always give a cougar an avenue of escape.
- Stay calm. Talk to the cougar in a confident voice.
- Pick all children up off the ground immediately. Children frighten easily and their rapid movements may provoke an attack.
- Do not run. Try to back away from the cougar slowly. Sudden movement or flight may trigger an instinctive attack.
- Do not turn your back on the cougar. Face the cougar and remain upright.
- Do all you can to make yourself seem larger and as intimidating as possible. Don't crouch down or try to hide. Pickup sticks or branches and wave them about.
- Any cougar seen on the job-site will cause an immediate notification of the Incident Commander. In addition, all workers within 500 metres of the animal are to seek immediate shelter within a vehicle or building. The Incident Commander shall assess the situation, observe the cougar for its intent, and determine a proper course of action to be taken. At no time will the cougar be approached by any workers for any reason other than at the direction of the Incident Commander.

If a Cougar Behaves Aggressively

- Arm yourself with a large stick, throw rocks, and speak loudly and firmly. Convince the cougar that you are a threat, not prey.
- If a cougar attacks, fight back! Many people have survived cougar attacks by fighting back with anything, including rocks, sticks, bare fists, and fishing poles.

Cougars are a vital part of our diverse wildlife. Seeing a cougar should be an exciting and rewarding experience, with both you and the cougar coming away unharmed. At the discretion of the On-Site Group Supervisor, the appropriate Environment Fish and Wildlife agency may be notified to determine the best course of action to be taken.



Animal Encounters, continued

Large Hooved Animals (Ungulates)

This family is comprised of several hooved omnivores common to Canadian lands. Unknown to most, ungulates cause more yearly fatalities than all predatory species combined. However, this is mainly due to vehicular accidents as opposed to acts of aggression. This class refers to:

- Bison
- Moose
- Mule and White tailed deer
- Elk
- Caribou

Ungulate Safety

- Generally speaking they prefer not being near people.
- The best line of defense is avoidance.
- Although physical size and appearance varies significantly, temperaments have been noted to be fairly similar between most species of ungulate.
- Mating season for most ungulates is during the fall months with the young being born in the spring; at both of these periods females and particularly males will become more aggressive and territorial.
- Like all wildlife, keeping a safe distance and never feeding the animals is advised.

If You Meet an Ungulate

The following 7 steps are suggested if experiencing a close encounter:

1. Avoid making similar noises, such as coughing, groaning, grunts, etc.
2. Do not approach the animal.
3. Stay calm and increase the distance between you and the animal while looking for an escape.
4. Run to safety once close enough.
5. Use noise deterrent if available.
6. Climb a tree if possible.
7. Report the incident to a work authority.

If It Behaves Aggressively

If confronted by an ungulate that feels threatened by you, consider it to be a dangerous situation.

- Look for an avenue of escape.

If knocked down:

- Curl up in a ball, protect head and neck with arms, and remain as still as possible. This is known as the “cannonball” position.
- Do not try to escape until the animal has moved a safe distance away.



Animal Encounters, continued

Rattle Snakes

Most North American snakes aren't poisonous. Exceptions in Canada include the rattlesnake and very rarely the copperhead snake. Their bites can be life-threatening. Both have slit-like eyes and are known as pit vipers. Their heads are triangular, with a depression (pit) midway between the eye and nostril on either side of the head. Rattlesnakes can be easily identified by the "rattle" noise created from the last segment of their tale when shaken.

Rattlesnake Safety

- Wear over-the-ankle or calf high boots.
- Do not put your hands where you cannot see.
- Use a tool when turning over rocks or boards.
- Always step on rocks and logs, never walk over them.
- Avoid walking through dense brush. If you must use a long stick or branch to beat the brush.
- Be careful when stepping over doorsteps. Snakes like to crawl along the edge of buildings.

If You Meet a Rattlesnake

- Remain calm. Do not panic.
- Stay at least five feet from the snake. Give the rattlesnake respect and space. Give the snake plenty of room.
- Avoid touching any snake. Back away slowly. Most snakes avoid people if possible and bite only when threatened or surprised.
- Do not try to kill the snake. Doing so is illegal and greatly increases the chance the snake will bite you.
- Alert your supervisor and others in the area of its location and update any hazard maps. Advise them to use caution and to respect the snake. Keep children and pets away.

In the event of a snake bite

- Remain calm, and inactive. By becoming agitated, your heart beats faster and you increase the flow of blood to the affected area and increase the amount of toxin able to find its way into your tissues.
- Immobilize the bitten arm or leg, and stay as quiet as possible to keep the poison from spreading through your body.
- Remove jewellery before you start to swell.
- Position yourself, if possible, so that the bite is at or below the level of your heart.
- Cleanse the wound, but don't flush it with water, and cover it with a clean, dry dressing.
- Do not put ice or cold substances on the bite.
- Apply a splint to reduce movement of the affected area, but keep it loose enough so as not to restrict blood flow.
- Mark the size of the affected area with a pen to track its progression.
- Drink plenty of fluids to maintain blood volume and prevent shock
- Don't try to capture the snake, but try to remember its colour and shape so you can describe it, which may help identify the snake for treatment, or try to get a picture of it from a safe distance.



Animal Encounters, continued

- Drive to a hospital or doctor's office ASAP, or have someone else drive. In the event you are several hours away from the nearest hospital, stay standing, stay hydrated, stay calm, and use a cell phone to call emergency responders.
- Do not make "X" incisions over the fang injuries or suck out the toxin. You will most likely cause excessive bleeding and/or additional necrosis (tissue death) and/or further infection from the germs in your mouth or surrounding environment.
- For shallow bite wounds, let it bleed out naturally. More blood will come out at first as generally there are anticoagulants in the venom. If a bite is deep enough to cause spurting blood (i.e. the strike hit a major artery and you're losing blood fast), immediately apply pressure to the wound and call emergency medical personnel.
- Do not use a tourniquet. While certain medical conditions still are helped with proper application of a tourniquet, these are few in number. In most cases, application of a tourniquet will cause necrosis and possibly elevate the need for amputation of the affected area distal to the heart. (a tourniquet is a tight encircling band applied around an arm or leg in an emergency to stop severe bleeding, e.g. tying a piece of cloth around your arm really tight) However, if treatment is more than 60 minutes away, using a constrictive band is advisable to prevent spread of the toxin. The band should be placed 5-10 cm above the bite and you should be able to place 2 fingers under the band.
- Snakes typically do not exhaust their venom after the initial bite, so be sure to remove yourself from the area as quick as possible. Furthermore, snakes have been known to have a bite reflex last up to 60 minutes after death.
- Watch the victim for signs of shock. This is treated by lying flat with feet elevated. Cover with warm clothes or blankets.

Wolves

Wolves generally avoid human interactions, unless they have become human habituated through repeated exposure to humans without any negative stimulus. It is not normal for wolves to attack or pursue humans. Please do your part to keep wolves where they belong, in the wild. As human population continues to grow, wolves are now considered an endangered species in Canada. In an attempt to keep wolves non-habituated, if seen, ensure all garbage has been properly disposed of and use noise to deter/scare the animal(s) away.

Wolf safety

- Wolves are notoriously intelligent animals; generally hunting in groups or packs surrounding their prey.
- Wolves have ranges of up to 400km.
- Wolves may breed anytime throughout the year. However, pups are mainly born between April-June at which time the entire pack will aggressively defend their young.
- Wolves are considered timid towards humans. Attacks are more likely if a wolf feels threatened, is sick, or assess their prey maybe injured and therefore more susceptible to attack.
- Secure all food items and never feed any other wildlife. Deer and small mammals can attract larger predators such as wolves.
- Howling is a form of communication for wolves. If heard within a close proximity, it is advised to find shelter in a vehicle or building.



Animal Encounters, continued

If you meet a wolf

In the unlikely event of a wolf or wolves threatening humans, here is what to do.

- Stay calm
- Never make sudden movement; back away slowly, never turning your back on the wolf.
- Leave the wolf an avenue of escape.
- Raise your voice and speak firmly.
- If the wolf continues to approach, wave your arms in an attempt to make yourself look bigger.
- Make use of any rocks, sticks, camping gear, fists, or feet to fend off an attack, Try to protect your neck and head from attacks.

Finding a wolf carcass

Wolves are an endangered species; in the event of finding a wolf carcass, take these following steps:

- Do not disturb or move any evidence.
- If possible, cover the carcass with a secured tarp or blanket in an attempt to preserve it.
- Once reported to your supervisor, call the appropriate provincial wildlife agency as they will determine the best course of action to be taken.

Bees and Wasps

The presence of native wild bees, and many species of wasps and hornets will be noted by all personnel working on the project.

Head-nets will be required PPE for all personnel when working in areas where large concentrations of bees, wasps, or hornets have been identified.

All personnel will inform the Incident Commander of any known allergy to, or past reaction to bee, wasp, or hornet stings.

If a “nest” is detected:

- All personnel will leave the area immediately.
- Call in the location of the “nest” to the Incident Commander.
- The area will be flagged as a hazard and its location written down for marking on the hazard map.

If a sting or attack occurs the following procedure will be followed:

- Remove the stinger within 30 seconds if possible.
- Do not squeeze the wound as this will release more venom.
- Wash the wound with soap and water.
- Apply cold pack.
- Watch for any of these signs and symptoms of allergic reaction and notify Incident Commander immediately if detected: rash, tightness of the chest and throat, swelling of the face, neck, and tongue, excessive sweating, dizziness, and / or difficulty breathing.



Animal Encounters, continued

EpiPens

Adrenaline (epinephrine) is a natural hormone released in response to stress. It is a natural "antidote" to the chemicals released during severe allergic reactions triggered by drug allergy, food allergy or insect allergy. It is destroyed by enzymes in the stomach, and so needs to be injected. When injected, it rapidly reverses the effects of a severe allergic reaction by reducing throat swelling, opening the airways, and maintaining blood pressure.

Use of adrenaline for treating anaphylaxis is First Aid.

IMPORTANT: The information provided is of a general nature and should not be used as a substitute for professional advice. If you think you may suffer from an allergic or other disease that requires attention, you should discuss it with your Incident Commander.

Warning / direction for EpiPen use:

- Never put thumb, fingers, or hand over the orange tip. (Tip colours vary by brand. Other colours are generally black and green.)
- Do not remove grey safety release until ready to use.
- Do not use if solution is discoloured or red flag appears in clear window as it may be expired.
- Do not place any other foreign objects in carrier with auto-injector, as this may prevent you from removing the auto-injector for use.

Steps for EpiPen use:

1. Unscrew the yellow or green cap off of the EpiPen carrying case and remove the EpiPen auto-injector from its storage tube.
2. Grasp unit with the black tip pointing downward.
3. Form fist around the unit (black tip down).
4. With your other hand, pull off the gray safety release.
5. Hold black tip near outer thigh.
6. Swing and jab firmly into outer thigh until it clicks so that unit is perpendicular (at a 90° angle) to the thigh. (Auto-injector is designed to work through clothing.)
7. Hold firmly against thigh for approximately 10 seconds. (The injection is now complete. Window on auto-injector will show red.)
8. Remove unit from thigh and massage injection area for 10 seconds.
9. Call for Help and seek immediate medical attention.
10. Carefully place the used auto-injector (without bending the needle), needle-end first, into the storage tube of the carrying case that provides built-in needle protection after use. Then screw the cap of the storage tube back on completely, and take it with you to the hospital emergency room.

Most of the liquid (about 90%) stays in the auto-injector and cannot be reused. However, you will have received the correct dose of the medication if the red flag appears in window.

Immediately after EpiPen use:

- Go immediately to the nearest hospital emergency room or call 911. You may need further medical attention. Take your used auto-injector with you.
- Tell the doctor that you have received an injection of epinephrine in your thigh.
- Give your used EpiPen to the doctor for inspection and proper disposal.



Section 5: External Agencies

SK Provincial Notification Matrix

MB Provincial Notification Matrix

ND State Notification Matrix

SK Provincial Lead Agency Roles

MB Provincial Lead Agency Roles

ND State Agency Roles

Government Consultation Summary

Specific Government Agency Roles

 Health Services

 Local Authority

SK Provincial Supporting Agency Roles

MB Provincial Supporting Agency Roles

Canada Federal Agency Roles

US Federal Agency Roles



Manitoba

Notification Requirements for Key Government Agencies

Incident Type	Initial Responders							Lead Agencies					Supporting Agencies & Other Government Contacts				
	a	b	c	d	e	f	g	h	i	j	k	l	m	n	o	p	
Sour Gas / HVP Release (Uncontrolled)	✓	✓	✓	✓	✓	✓	✓	✓	✓	✓	✓	✓	✓	✓	✓	✓	
Chlorine Gas Release	✓	✓	✓	✓	✓	✓	✓	✓	✓	✓	✓	✓	✓	✓	✓	✓	
Sweet Combustible Gas Release	✓	✓	✓	✓	✓	✓	✓	✓	✓	✓	✓	✓	✓	✓	✓	✓	
Spills / Transportation Incidents (Unrefined Products)**	✓	✓	✓	✓	✓	✓	✓	✓	✓	✓	✓	✓	✓	✓	✓	✓	
Spills / Rail or Trucking Incidents (Refined Products)**	✓	✓	✓	✓	✓	✓	✓	✓	✓	✓	✓	✓	✓	✓	✓	✓	
Serious Injury or Death (including Vehicle Accidents)	✓	✓	✓	✓	✓	✓	✓	✓	✓	✓	✓	✓	✓	✓	✓	✓	
Missing Person	✓	✓	✓	✓	✓	✓	✓	✓	✓	✓	✓	✓	✓	✓	✓	✓	
Fire / Explosion / B.L.E.V.E	✓	✓	✓	✓	✓	✓	✓	✓	✓	✓	✓	✓	✓	✓	✓	✓	
Pressure Vessel or Piping Incident	✓	✓	✓	✓	✓	✓	✓	✓	✓	✓	✓	✓	✓	✓	✓	✓	
Electrical Incident	✓	✓	✓	✓	✓	✓	✓	✓	✓	✓	✓	✓	✓	✓	✓	✓	
Motor Vehicle Accident (No injuries)	✓	✓	✓	✓	✓	✓	✓	✓	✓	✓	✓	✓	✓	✓	✓	✓	
Security Incidents	✓	✓	✓	✓	✓	✓	✓	✓	✓	✓	✓	✓	✓	✓	✓	✓	
On-Site Incident Involving E2 Regulated Substance	✓	✓	✓	✓	✓	✓	✓	✓	✓	✓	✓	✓	✓	✓	✓	✓	

✓ Compulsory contact

13-Jul-23

* CER is a compulsory contact only for emergencies and near-misses involving CER regulated sites and inter-provincial pipelines.

** Refer to the Canadian Petroleum Industry Release Reporting Requirements chart included in the ERP.

EMO Upon receipt of emergency notification, the EMO will then assess and notify the appropriate provincial and federal departments, local authorities & municipalities, Crown corporations, other non government agencies such as critical suppliers, service providers and outside contractors.

- Contact the local Fire Department if there is potential for secondary fires resulting from the ignition of spilled liquids or escaping gases.
 - Contact Economic Development, Investment & Trade (EDIT) - Resource Development (Petroleum) for incidents occurring at facilities approved by the department, spills greater than 0.5m³, any spill on land outside of the company's lease, a fire, or a blow-out.
 - Contact the Regional Health Authority (RHA) if the incident has the potential to impact public health (e.g., contaminated drinking water).
 - Contact the Manitoba Workplace Safety and Health if there is a serious injury requiring medical attention or death as a result of an incident (worker-related issues).
 - Contact Manitoba Transportation and Infrastructure or the RCMP if the emergency affects a highway designated by 1, 2, or 3 digits (e.g., Hwy 2, Hwy 47, Hwy 837). Manitoba Transportation and Infrastructure and RCMP have the authority to shut down highways.
 - Contact the Workers Compensation Board within 5 days of becoming aware of an injury or illness that will result in lost work.
 - Contact Manitoba Environment, Climate and Parks if the incident impacts sensitive or natural areas, crown lands, forests, farm lands, wildlife, or wet areas / water bodies.
 - Environment & Climate Change Canada (ECCC) will be notified by Manitoba Environment, Climate and Parks as required for incidents involving regulated substances at E2 registered facilities, incident impacts sensitive or natural areas, crown lands, farm lands, wildlife, or wet areas / water bodies.
 - Contact the Canadian Transport Emergency Centre (CANUTEC) when a highway is shut down, there is an injury or fatality, there is lost, stolen or unlawfully interfered with dangerous goods (except Class 9), the incident involves infectious substances, there is an accidental release from a cylinder that has suffered a catastrophic failure, where the shipping documents display CANUTEC's telephone number, where a railway vehicle, ship, aircraft aerodrome or an air cargo facility is involved, when a facility is closed, evacuation/shelter-in-place procedures take place as a result of the transportation of dangerous goods, containment has been damaged and integrity compromised, or the centre/stub sill of a tank car is broken or there is a crack in the metal ≥ 15cm(6"). CANUTEC can also provide guidance on handling procedures for toxic material releases.
 - Emergency Response Assistance Canada will only respond to incidents that involve the following UN numbers: 1075 (Propane, Butane, etc.) and 1010 (Butadiene); with a tank storage capacity of 450 litres or greater. Advisory assistance will be provided to incidents involving tank storage capacities less than 450 litres.
 - Contact the Department of Fisheries and Oceans Canada to report an oil spill that occurs in or around fresh and marine waters.
 - Indian Oil & Gas (IOGC), the First Nation and the provincial authority must be notified immediately in the event of any health or environment-threatening emergency or off-lease spills on First Nation reserve lands. On-lease spills greater than 1m³ must be reported to IOGC immediately.
- In the event of a fatality, request that the RCMP contact the Medical Examiner. The RCMP must be notified in the case of lost, stolen or misplaced explosives, radioactive materials or infectious substances.
 - Local Authorities include: cities, towns, villages, rural municipalities, Métis settlements or First Nations reserves.
 - Notify the Manitoba Emergency Management Organization of any emergency that has resulted, or may result in: death or injury to multiple persons, significant damage to multiple properties, critical infrastructure, the environment, the economy, any emergency which is likely to overwhelm local resources, or any emergency which may require Provincial or Federal assistance.
 - Contact the Canada Energy Regulator (via the Transportation Safety Board of Canada) for emergencies and near-misses involving CER regulated sites and inter-provincial pipelines.
 - Manitoba Environment, Climate and Parks - Environmental Branch, Fire Branch, Forestry Branch, Parks and Natural Areas Branch, Protected Areas Branch, Sustainable Resource Management, Wildlife & Ecosystem Protection Branch.



North Dakota

Notification Requirements for Key Government Agencies

Incident Type	Initial Responders										Lead Agencies					Supporting Agencies & Other Government Contacts				
	Agency or Resource	Local Fire Department	Police / Sheriff	NDIC - North Dakota Highway Patrol 1	County & Tribal Emergency Management	NDDEQ - North Dakota Dept. of Health	SERC - North Dakota Dept. of Health	LEPC - State Emergency Response Committee	TERC - Local Emergency Response Services	NRC - Tribal Emergency Response Commission	OSHA - National Response Commission	WSI - Occupational Safety and Health Administration 3	NDDEQ - Boiler Inspection Program 5	NDDOT - North Dakota Dept. of Transportation	BLM - Bureau of Land Management - US Dept of the Interior	USDA - Forest Service District	CSB - Chemical Safety and Hazard Investigation Board			
Sour Gas / HVP Release (Uncontrolled)	a	✓	✓	✓	✓	✓	✓	✓	e	e	e	f					g	h	i	j
Chlorine Gas Release	a	✓	✓	✓	✓	✓	✓	✓	e	e	e	f					g	h	i	j
Sweet Combustible Gas Release	a	✓	✓	✓	✓	✓	✓	✓				f					g	h	i	
Spills / Transportation Incidents (Unrefined Products)*	a	✓	✓	✓	✓	✓	✓	✓	e	e	e	f					g		i	
Spills / Rail or Trucking Incidents (Refined Products)*	a	✓	✓	✓	✓	✓	✓	✓	e	e	e	f					g		i	
Serious Injury or Death (including Vehicular Accidents)	✓	a	✓									f	✓	✓			g	h		j
Missing Person		✓																		
Fire / Explosion / B.L.E.V.E.	✓	✓	✓	c	c	d	d					f		✓			g	h	i	j
Pressure Vessel or Piping Incident		✓	✓	c	c	d	d					f		✓			h	i	j	
Electrical Incident		✓	b																	
Motor Vehicle Accident (No injuries)		✓															g			
Security Incidents		✓	b			d														
Non-Transportation Related Spill		✓	✓	✓	✓	✓	✓	✓	e	e	e	f					h	i	j	

✓ Compulsory contact

2021-05-05

* Refer to the Petroleum Industry Release Reporting Requirements chart included in the ERP.



- a) Contact the local Fire Department if there is potential for secondary fires resulting from the ignition of spilled liquids or escaping gases.
 - b) NDIC will be notified through the Unified Spill Reporting System of any incident that may be an imminent threat to public health, safety or the environment.
 - c) County & Tribal Emergency Management will be notified through the Unified Spill Reporting System of any incident or spill involving hazardous materials that may have an adverse effect on human health or environment (air, water and land).
 - d) NDDoH and NDDEQ will be notified through the Unified Spill Reporting System of any injury, death, incident or spill involving hazardous materials that may have an adverse effect on human health or environment (air, water and land).
 - e) SERC, LEPC and TERC will be notified through the Unified Spill Reporting System. EPCRA extremely hazardous substances (EHS) as per Appendix A & B of 40 CFR Part 355 that are released off lease in quantities equal to or greater than their Reportable Quantities (RQs) must be reported immediately to the SERC, LEPC & TERC (through Unified Spill Reporting System) as applicable. CERCLA hazardous substances (defined in 40 CFR part 302) that are not part of the Petroleum Exclusion (as they are added after the refining process), that are released into the environment (not contained in a building), in quantities equal to or greater than their Reportable Quantities (RQs) must also be reported to the SERC, LEPC & TERC (through Unified Spill Reporting System). In the event of a transportation incident 911 must be notified instead. Releases of CERCLA regulated substances must also be reported to the NRC.
 - f) The National Response Center (NRC) is the designated federal point of contact for reporting all oil, chemical, radiological, biological and etiological discharges into the environment. Immediate notice to the NRC is required for any release that impacts water. Immediate notice to the NRC is required for any pipeline, LNG Facility, or underground natural gas storage facility release that results in any of the following: 1) An unexpected loss of more than 3 million cubic feet or more of gas. 2) Death or hospitalization. 3) \$50,000 or more in damages. 4) An emergency shutdown of an LNG or Underground Natural Gas Storage Facility. 5) Any impact to water. 6) Anything else the operator deems as a significant incident. Immediate notice to the NRC is required for any transportation incident that results in any of the following as a direct result of the hazardous material or waste 1) Death or hospitalization. 2) The general public being evacuated for more than 1 hour. 3) A major transportation artery or facility closed for more than 1 hour. 4) The flight pattern or routine of an aircraft being altered. 5) Fire, breakage or spillage of a radioactive or infectious substance. 6) The release of 450 litres or 450 kg of a marine pollutant. 7) Anything else the carrier deems as a continuing danger to life. CERCLA hazardous substances (defined in 40 CFR part 302) that are not part of the Petroleum Exclusion (as they are added after the refining process), that are released into the environment (not contained in a building), in quantities equal to or greater than their Reportable Quantities (RQs) must be reported to the NRC as per 40 CFR part 302. Note release of CERCLA hazardous substances must also be reported to the SERC, LEPC & TERC. The NRC notifies the pre-designated On-Scene Coordinator from the EPA (incidents impacting inland areas & waters) or U.S. Coastguard (incidents impacting coastal waters & great lakes) who will direct the federal government's response to the incident. If you cannot contact the NRC you can contact the EPA or US Coast Guard.
 - g) Contact NDDOT and North Dakota Highway Patrol (NDHP) if the incident involves a hazardous material release, other than fuel spilled from the fuel tanks involved in the accident and affects a highway. NDDOT and NDHP have the authority to shut down highways. Also notify of any incident involving a fatality, bodily injury in which that person receives immediate medical attention away from the scene of the accident, or at least one of the vehicles involved in the accident had to be towed from the scene.
 - h) The BLM must be notified of any of the following Major Undesirable Events (MUEs) on public lands: 1) A release of 100 bbls or more of oil, saltwater or toxic liquid that is not entirely contained to the facility. 2) A release of 500 thousand or more cubic feet of gas. 3) Any fire that consumes more than 100 bbls of liquid or 500 thousand cubic feet of gas. 4) Any release or fire that occurs in a sensitive area (parks, recreation sites, wildlife refuges, lakes, reservoirs, streams, or urban or suburban areas). 5) Any accident that involves a fatal injury. 6) Every blowout (loss of control of any well).
 - i) Notify the USDA Forest Service District of any of the following incidents on USDA Forest Service property: 1) Any impact to water. 2) A release of 100 bbls or more of oil, saltwater or toxic liquid that is not entirely contained to the facility. 3) A release of 500 thousand or more cubic feet of gas.
 - j) Notify the CSB of any accidental release (i.e. unanticipated emission into the ambient air from a stationary source) of an extremely hazardous substance (EHS substance under EPCRA, regulated substance under Section 112(r) of the Clean Air Act, or other extremely hazardous substance) resulting in a fatality, hospitalization, or substantial property damage (greater than or equal to \$1 million).
- 1 In the event of a fatality, request that local law enforcement contact the North Dakota State Forensic Examiner's Office. Law enforcement should be notified in the case of lost, stolen or misplaced explosives, radioactive materials or infectious substances.
 - 2 Tribal Emergency Management will be notified through the Unified Spill Reporting System of any spill which enters, or threatens to enter waterbodies within or flow through first nations lands or any spill that poses and impact to first nations lands or properties.
 - 3 The Occupational Safety and Health Administration (OSHA) must be notified within 8 hours of learning about: the death of any employee from a work-related incident and the in-patient hospitalization of three or more employees as a result of a work-related incident. Employers must report all fatal heart attacks that occur at work and any vehicle accidents within a construction zone on public streets.
 - 4 If an injury is life threatening, go to the nearest emergency room. In all other cases, report an injury to your employer immediately. The employer is required to file a FROI (First Report of Injury) form with WSI within 7 days of receiving notice of an injury. A claim for death benefit must be filed within 2 years of worker's date of death.
 - 5 Notify NDDEQ - Boiler Inspection Program; When an accident occurs which requires major repairs as defined in subsection 20 of section 45-12-01-01, the owner or user shall immediately notify the chief inspector and submit a detailed report of the accident. In case of an explosion, notice must be given immediately by telephone and the parts of the boiler may not be removed or disturbed before an inspection has been made by an inspector, unless for the purpose of saving human life or property. When an accident occurs which requires major repairs or results in the boiler being removed from service, that accident must be reported to the chief boiler inspector within 30 days of the insuring or inspecting company first becoming aware of the accident. The chief boiler inspector shall be notified of all anticipated and major repairs or alterations to a boiler before work is started.

North Dakota Notification Matrix

Before the Incident

During the Incident

After the Incident

*EDIT

*Manitoba Emergency Management Organization

Local Authority / Rural Municipality

- The Manitoba Economic Development, Investment and Trade (EDIT) - Resource Development (Petroleum) branch administers provisions under The Oil and Gas Act and The Oil and Gas Production Tax Act relating to exploration, development, production and transportation of oil and gas.
- The Branch develops, recommends, implements and administers policies and legislation, to provide for the sustainable development of Manitoba's oil and gas resources. The Branch deals with matters relating to well spacing, production allowable, pool designations, salt water disposal, enhanced recovery projects and unitization. The Branch publishes several reports each year, providing the public, industry and government with information on the petroleum industry in Manitoba.
- Establish processes to receive and address community concerns.

- The Manitoba Emergency Management Organization (EMO) is responsible for overseeing and coordinating all aspects of emergency preparedness in the Province, and managing, directing and coordinating the response of all departments to a disaster or major emergency.
- EMO is responsible for maintaining the [Manitoba Emergency Plan](#). The Plan is the linchpin in EMO's capacity to provide a coordinated and effective response to emergencies and disasters. It explains the provincial emergency response concept, emergency response structure, and the roles and responsibilities of provincial departments and agencies responding to emergencies and disasters.
- EMO assists with major emergencies and disasters through coordination of the disaster response process, including the coordination of provincial, federal and non-government agency resources to assist municipalities. Services provided to the municipalities include consulting, planning support, event activity, post emergency reports, and public information on response activities.
- EMO is responsible to conceive, develop and coordinate a range of recovery programs and policy. EMO provides leadership in developing holistic recovery strategies for implementation in the wake of a major disaster. As such EMO has strong connections to non-governmental organizations who contribute to the overall recovery strategy.
- Prepare and maintain disaster assistance policies and guidelines for emergencies and disasters in Manitoba.
- Develop and maintain policy and procedures for the submission and processing of claims for disaster assistance.
- Prepare a provincial emergency preparedness program and a provincial emergency plan, and conduct regular reviews and revisions of the program and plan.
- Establish and main a registry containing a copy of every emergency plan and emergency management program in effect in the province.
- Review, modify and approve emergency preparedness programs and emergency plans.
- Assist local authorities in practicing their local emergency plans by conducting table top exercises.
- Development and maintenance of procedures for submitting and processing of claims.
- Provide a public disaster assistance awareness program.
- Consulting with government departments and the private sector on establishing and implementing disaster assistance programs.

- Work with the operator to effectively prepare for a petroleum industry incident. Provide input to the industrial operator's site-specific plan to ensure it is compatible with the Municipal Emergency Plan (MEP), where feasible.
- Participate in industrial operators' preparatory training and exercises where possible.
- Train personnel to carry out functions as assigned by MEP or procedures.
- Maintain 24 hour emergency contact numbers.
- May enter into mutual aid agreements with the government, any local authority, any department or any person with respect to the establishment, development or implementation of emergency preparedness programs and emergency plans and the conduct of emergency operations.
- Must review and revise its emergency preparedness programs and emergency plans from time to time as required by the regulations, to ensure that they continue to meet the standards prescribed by regulation.
- Provide fire protection services within its boundaries to reduce the danger of fire.

- Advise and assist in the implementation of petroleum demand restraint measures prior to or during a declared petroleum emergency.
- Liaise with the Government of Canada respecting the implementation of the *Energy Supplies Emergency Act (Canada)*.
- Receive information pertaining to petroleum industry incidents.
- Determine the emergency level of an incident through consultation with the licensee.
- Dispatch representative to the site of the incident, as required.
- Confirm that local resources have been notified as appropriate.
- Identify and request initial provincial resources to support the incident, to be coordinated at the regional level if necessary through a local or regional EOC.
- Either notify all government agencies or instruct the operator on which government agencies they're to notify during an emergency
- Send a representative to the OSCP.
- Bring in expertise from other areas, as required.
- Provide timely situation reports to other government departments activated by this plan.

- Provide assistance to local authorities and provincial departments in the implementation of emergency plans, establishing Emergency Operations Centres, reception centres for evacuees.
- Alert provincial departments and agencies likely to be involved in the emergency.
- Manage, direct and coordinate the response of all departments to a major emergency or disaster. This includes Provincial agencies, Crown Corporations, National Parks, First Nations or other properties within federal jurisdictions.
- Dispatch Emergency Preparedness advisor to the affected community.
- Provision, operation and administration of the Emergency Mobile Command Centre.
- Activation, operation and administration of the Manitoba Emergency Coordination Centre. In addition to the static MECC in Winnipeg, EMO maintains a deployable MECC that can be dispatched closer to the site of the emergency.
- Submission of "Requests for Emergency Response Assistance" to the Government of Canada and / or the Canadian Forces when the Province's capacity to deal with the emergency is exceeded or where specialized resources are required.
- Requesting the assistance of the Director of Communication Services (CH&T) to:
 - Establish and coordinate Media and/or Public Information Centres, which shall report to the Executive Coordinator, the Deputy Minister and / or the Minister.
 - Coordinate the activities and media releases of all Departmental Communication Officers required, at departmental emergency operation centres and emergency sites.
 - Coordinate news releases and public service announcements related to the emergency response.
 - Coordinate and manage local and visiting media personnel.
- Communication and administration of Government Policy on disaster assistance in accordance with the Emergency Measures Act and Disaster Financial Assistance Policy.
- EMO is the provincial aggregator for the National Public Alerting System. EMO has the capability to provide broadcast interrupted emergency messages through radio and television where and when required.
- EMO will take primary responsibility of an emergency or disaster where unusual circumstances exist:
 - No local government exists.
 - The local government no longer has the capacity to respond.
 - The local government is unable to implement an appropriate on-site system of emergency management.

- Respond to and assess the emergency incident.
- Establish contact with the industrial operator in order to:
 - Obtain additional hazard information.
 - Determine where road blocks should be or are established.
 - Determine the direction of approach to the incident.
 - Determine if there are any injuries.
 - Find out what response and public protection actions have been taken.
 - Identify the location of the On-site Command Post (OSCP) and any Emergency Operations Centres (EOCs).
- Activate the MEP, when required.
- Manage the Local Authority's emergency response.
- Activate the emergency public warning system to alert people to life threatening hazards, as required.
- Activate the Municipal EOC (MEOC), as required.
- Initiate public protection measures, as necessary.
- May dispatch a representative to the Government EOC (GEOC), when it is established, to coordinate the response, if requested.
- In the event of an emergency or disaster in a municipality, the local authority may declare a state of local emergency for a period of 14 days from the date of the making thereof with respect to part or all of the municipality affected or likely to be affected by the emergency or disaster.
 - A local authority that has declared a state of local emergency must give the coordinator any information he or she requests about the authority's response to the disaster or emergency and its effects on the municipality.
 - Notify Manitoba EMO that an Emergency Prevention Order or State of Local Emergency has been declared.
- When possible, work with all other responders to establish a single Regional EOC (REOC).
- Establish a public information service, including the use of the news media to inform and instruct the public of the emergency and of any protective actions to be taken.
- Coordinate news releases with the licensee, if required.
- Inform Manitoba EMO and the public when the emergency is over.
- At the site of an emergency or disaster, a local authority must:
 - Carry out an action,
 - Cease an action it is carrying out, or
 - Change the way it is carrying out an action if directed to do so by the fire commissioner.

- As part of the "lessons-learned" process, recommend any mitigative actions that may reduce the event from re-occurring.
- Carry out investigations.
- Notify all participants when the event has concluded and there is no longer any hazard to the public.

- Provide an accurate record of the provincial and municipal experience in dealing with the emergency.
- Provide a means of assessing the strengths and deficiencies of the province's response to the emergency, including departmental, municipal and voluntary organizations.
- Identify methods of enhancing the response and subsequently, the development of programs to implement proposals.
- Investigate claims.
- As required, MEMO will be responsible for the preparation of a provincial report which may include:
 - An executive summary.
 - Provincial Emergency Response (including local response).
 - Chronological sequence of significant events.
 - Overall emergency costs on a departmental basis.
 - The overall comments and recommendations (from debriefing meetings, departmental / municipal reports).
 - Department / agency / municipal reports.
 - The printing and distribution of the provincial report.
- Receive and assess all disaster assistance claims from local authorities, government departments, the Government of Canada or the private sector.
- Compilation and publication of the provincial post-emergency report.

- Complete a "lessons learned" process based on the scope of involvement and provide any feedback to the industrial operator.
- Participate in multi-agency debriefings.

Lead Agency Roles



Lead Agency Roles



Emergency Services

Before the Incident

In any emergency, initial requests for assistance from the public are usually directed to emergency responders, i.e. police, fire or EMS providers through 911 or a local emergency telephone number. It is the fire department that usually has the training, equipment and knowledge to safely and effectively manage many of the large scale emergencies.

- Maintain readiness status for emergency notification.
- Participate in industrial operators' exercises where possible.
- Maintain 24 hour emergency contact numbers.

During the Incident

Local authorities, provincial or federal departments and agencies (including E911 centres and first responders) which become aware of an event that either has, or could, result in a major emergency or disaster, shall notify the EMO as soon as possible, by calling the **EMO Duty Officer 24/7 at 204-945-5555**.

Any emergency that has resulted, or may result in:

- Death or injury to multiple persons.
- Significant damage to:
 - Multiple properties,
 - Critical infrastructure,
 - The environment,
 - The economy, or
- Any emergency which is likely to overwhelm local resources.
- Any emergency which may require Provincial or Federal assistance (other than specialist resources that are provided in the ordinary course).

RCMP

- Advise local authorities respecting the maintenance of law and order.
- Provide security control of the emergency operations area(s).
- Provide security control of evacuated area(s).
- Provide traffic and crowd control.
- Administer public access and egress system within the flood plain and community ring dikes, in cooperation with the Departments of Conservation, Transportation and Infrastructure, and Water Stewardship.
- Assist the Chief Medical Examiner.
- Conduct search and rescue of missing persons.
- Coordinate forced evacuations.
- Maintain law and order and assist the operator with local security but would require discussion with the local police at the time.
- Assist with mobilization of additional resources.
- Typically would not be involved in setting up or maintaining roadblocks unless the emergencies impacted or required the closure of 1, 2 and 3 digit Provincial or Secondary highways.
- Establish and maintain communications with industrial operator.
- Dispatch a representative to the off-site Regional Emergency Operations Centre, when established, to coordinate the response.
- Coordinate with the industrial operator both the establishment and the administration of reception centres for evacuees.
- RCMP or local police would also become involved if there are fatalities as they are required to participate in the investigations. This could be through the medical examiner.
- The Office of the Fire Commissioner (OFC) has a working relationship with the RCMP and the RCMP may conduct selected duties of the Fire Commissioner where the fire's impact is not significant.
- Maintain a 24 hour emergency contact number where resources can be accessed for a response related to Emergency Response Plans.

Fire

- Respond to and assess emergency incident to the scope of their abilities.
- Establish a unified OSCP / ICP (On-site Command Post / Incident Command Post).
- Communicate to MEOC and provide site reps as required.
- Assist with fire protection where trained personnel are available.
- Provide emergency medical assistance, as required.
- Coordinate news releases with the licensee, if required.
- Provide response to dangerous goods incidents.
- By special order issued by the Minister responsible for this act (Emergency Medical Response and Stretcher Transportation), fire department personnel **MAY** operate an ambulance at the scene of an emergency incident when requested to do so by the EMS attendant(s), providing that the municipal fire fighter(s) possess the required Class 4 drivers license.

EMS

- Respond to and assess emergency incident to the scope of their abilities.
- Provides situational awareness and coordinates resources through the PREOCs and PECC.
- Provide emergency medical assistance, as required.
- Establish Incident Command.
- Provide first aid on site.
- Initiate health mutual aid if necessary.
- Log all actions and decisions.

After the Incident

- Complete a "lessons learned" process based on the scope of involvement and provide any feedback to the industrial operator.
- Participate in multi-agency debriefings.

*Regional Health Authority

- The regional health authorities are responsible within the context of broad provincial policy direction, for assessing and prioritizing needs and health goals, and developing and managing an integrated approach to their own health care system.
- Land ambulance services are delivered by a combination of providers including the Regional Health Authorities and other service providers under an agreement with regional health authorities (e.g., municipalities, First Nation communities).
- The air ambulance service providers include the provincial Lifelight program (specialized air ambulance services operated provincially) and private air ambulance providers (basic air ambulance services).

- Provide representation at the off-site REOC or at the GEOC when established, if requested and if available.
- Provide accurate information to the public concerning the incident.
- Provide guidance and assistance at evacuation centre(s).
- Provide health related information about toxic chemicals and by-products.
- Provide guidance on public health advisories, public evacuation and sheltering.
- Provide guidance on rescinding a declaration of public evacuation and on allowing re-occupancy.
- Investigate health complaints from the public.
- Provide advice to the government GEOC and to the REOC on existing or potential health effects associated with the incident where possible.
- Provide health advice and safety levels for any health or special care facilities and for other persons that are likely to be sensitive from the impact as a result of the incident.
- Ensure local hospitals are alerted when there is potential for an impact from a release.
- Coordinate the provision of medical services during an emergency.
- Where appropriate and necessary, can declare a Local State of Public Health Emergency.
- When possible work with all other responders to establish a single Regional Emergency Operations Centre (REOC).

- Compile and maintain health related records and logs.
- Complete a "lessons learned" process based on the scope of involvement and provide any feedback to the industrial operator.
- Participate, where possible, in event debriefings.
- Complete incident related reports.
- Provide guidance on assessing and mitigating public health risks due to any residual environmental contamination following an event.

Before the Incident

*NRND

- The Natural Resources and Northern Development - Regulatory Services (Oil and Gas) branch administers provisions under The Oil and Gas Act and The Oil and Gas Production Tax Act relating to exploration, development, production and transportation of oil and gas.
- The Branch develops, recommends, implements and administers policies and legislation, to provide for the sustainable development of Manitoba's oil and gas resources. The Branch deals with matters relating to well spacing, production allowable, pool designations, salt water disposal, enhanced recovery projects and unitization. The Branch publishes several reports each year, providing the public, industry and government with information on the petroleum industry in Manitoba.
- Establish processes to receive and address community concerns.

*Manitoba Emergency Measures Organization

- The Manitoba Emergency Measures Organization (EMO) is responsible for overseeing and coordinating all aspects of emergency preparedness in the Province, and managing, directing and coordinating the response of all departments to a disaster or major emergency.
- EMO is responsible for maintaining the [Manitoba Emergency Plan](#). The Plan is the linchpin in EMO's capacity to provide a coordinated and effective response to emergencies and disasters. It explains the provincial emergency response concept, emergency response structure, and the roles and responsibilities of provincial departments and agencies responding to emergencies and disasters.
- EMO assists with major emergencies and disasters through coordination of the disaster response process, including the coordination of provincial, federal and non-government agency resources to assist municipalities. Services provided to the municipalities include consulting, planning support, event activity, post emergency reports, and public information on response activities.
- EMO is responsible to conceive, develop and coordinate a range of recovery programs and policy. EMO provides leadership in developing holistic recovery strategies for implementation in the wake of a major disaster. As such EMO has strong connections to non-governmental organizations who contribute to the overall recovery strategy.
- Prepare and maintain disaster assistance policies and guidelines for emergencies and disasters in Manitoba.
- Develop and maintain policy and procedures for the submission and processing of claims for disaster assistance.
- Prepare a provincial emergency preparedness program and a provincial emergency plan, and conduct regular reviews and revisions of the program and plan.
- Establish and main a registry containing a copy of every emergency plan and emergency management program in effect in the province.
- Review, modify and approve emergency preparedness programs and emergency plans.
- Assist local authorities in practicing their local emergency plans by conducting table top exercises.
- Development and maintenance of procedures for submitting and processing of claims.
- Provide a public disaster assistance awareness program.
- Consulting with government departments and the private sector on establishing and implementing disaster assistance programs.

Local Authority / Rural Municipality

- Work with the operator to effectively prepare for a petroleum industry incident. Provide input to the industrial operator's site-specific plan to ensure it is compatible with the Municipal Emergency Plan (MEP), where feasible.
- Participate in industrial operators' preparatory training and exercises where possible.
- Train personnel to carry out functions as assigned by MEP or procedures.
- Maintain 24 hour emergency contact numbers.
- May enter into mutual aid agreements with the government, any local authority, any department or any person with respect to the establishment, development or implementation of emergency preparedness programs and emergency plans and the conduct of emergency operations.
- Must review and revise its emergency preparedness programs and emergency plans from time to time as required by the regulations, to ensure that they continue to meet the standards prescribed by regulation.
- Provide fire protection services within its boundaries to reduce the danger of fire.

During the Incident

- Advise and assist in the implementation of petroleum demand restraint measures prior to or during a declared petroleum emergency.
- Liaise with the Government of Canada respecting the implementation of the *Energy Supplies Emergency Act (Canada)*.
- Receive information pertaining to petroleum industry incidents.
- Determine the emergency level of an incident through consultation with the licensee.
- Dispatch representative to the site of the incident, as required.
- Confirm that local resources have been notified as appropriate.
- Identify and request initial provincial resources to support the incident, to be coordinated at the regional level if necessary through a local or regional EOC.
- Either notify all government agencies or instruct the operator on which government agencies they're to notify during an emergency
- Send a representative to the OSCP.
- Bring in expertise from other areas, as required.
- Provide timely situation reports to other government departments activated by this plan.

- Provide assistance to local authorities and provincial departments in the implementation of emergency plans, establishing Emergency Operations Centres, reception centres for evacuees.
- Alert provincial departments and agencies likely to be involved in the emergency.
- Manage, direct and coordinate the response of all departments to a major emergency or disaster. This includes Provincial agencies, Crown Corporations, National Parks, First Nations or other properties within federal jurisdictions.
- Dispatch Emergency Preparedness advisor to the affected community.
- Provision, operation and administration of the Emergency Mobile Command Centre.
- Activation, operation and administration of the Manitoba Emergency Coordination Centre. In addition to the static MECC in Winnipeg, EMO maintains a deployable MECC that can be dispatched closer to the site of the emergency.
- Submission of "Requests for Emergency Response Assistance" to the Government of Canada and / or the Canadian Forces when the Province's capacity to deal with the emergency is exceeded or where specialized resources are required.
- Requesting the assistance of the Director of Communication Services (CH&T) to:
 - Establish and coordinate Media and/or Public Information Centres, which shall report to the Executive Coordinator, the Deputy Minister and / or the Minister.
 - Coordinate the activities and media releases of all Departmental Communication Officers required, at departmental emergency operation centres and emergency sites.
 - Coordinate news releases and public service announcements related to the emergency response.
 - Coordinate and manage local and visiting media personnel.
- Communication and administration of Government Policy on disaster assistance in accordance with the Emergency Measures Act and Disaster Financial Assistance Policy.
- EMO is the provincial aggregator for the National Public Alerting System. EMO has the capability to provide broadcast interrupted emergency messages through radio and television where and when required.
- EMO will take primary responsibility of an emergency or disaster where unusual circumstances exist:
 - No local government exists.
 - The local government no longer has the capacity to respond.
 - The local government is unable to implement an appropriate on-site system of emergency management.

- Respond to and assess the emergency incident.
- Establish contact with the industrial operator in order to:
 - Obtain additional hazard information.
 - Determine where road blocks should be or are established.
 - Determine the direction of approach to the incident.
 - Determine if there are any injuries.
 - Find out what response and public protection actions have been taken.
 - Identify the location of the On-site Command Post (OSCP) and any Emergency Operations Centres (EOCs).
- Activate the MEP, when required.
- Manage the Local Authority's emergency response.
- Activate the emergency public warning system to alert people to life threatening hazards, as required.
- Activate the Municipal EOC (MEOC), as required.
- Initiate public protection measures, as necessary.
- May dispatch a representative to the Government EOC (GEOC), when it is established, to coordinate the response, if requested.
- In the event of an emergency or disaster in a municipality, the local authority may declare a state of local emergency for a period of 14 days from the date of the making thereof with respect to part or all of the municipality affected or likely to be affected by the emergency or disaster.
 - A local authority that has declared a state of local emergency must give the coordinator any information he or she requests about the authority's response to the disaster or emergency and its effects on the municipality.
 - Notify Manitoba EMO that an Emergency Prevention Order or State of Local Emergency has been declared.
- When possible, work with all other responders to establish a single Regional EOC (REOC).
- Establish a public information service, including the use of the news media to inform and instruct the public of the emergency and of any protective actions to be taken.
- Coordinate news releases with the licensee, if required.
- Inform Manitoba EMO and the public when the emergency is over.
- At the site of an emergency or disaster, a local authority must:
 - carry out an action,
 - cease an action it is carrying out, or
 - change the way it is carrying out an action if directed to do so by the fire commissioner.

After the Incident

- As part of the "lessons-learned" process, recommend any mitigative actions that may reduce the event from re-occurring.
- Carry out investigations.
- Notify all participants when the event has concluded and there is no longer any hazard to the public.

- Provide an accurate record of the provincial and municipal experience in dealing with the emergency.
- Provide a means of assessing the strengths and deficiencies of the province's response to the emergency, including departmental, municipal and voluntary organizations.
- Identify methods of enhancing the response and subsequently, the development of programs to implement proposals.
- Investigate claims.
- As required, MEMO will be responsible for the preparation of a provincial report which may include:
 - An executive summary.
 - Provincial Emergency Response (including local response).
 - Chronological sequence of significant events.
 - Overall emergency costs on a departmental basis.
 - The overall comments and recommendations (from debriefing meetings, departmental / municipal reports).
 - Department / agency / municipal reports.
 - The printing and distribution of the provincial report.
- Receive and assess all disaster assistance claims from local authorities, government departments, the Government of Canada or the private sector.
- Compilation and publication of the provincial post-emergency report.

- Complete a "lessons learned" process based on the scope of involvement and provide any feedback to the industrial operator.
- Participate in multi-agency debriefings.

Lead Agency Roles



Emergency Services

Before the Incident

In any emergency, initial requests for assistance from the public are usually directed to emergency responders, i.e. police, fire or EMS providers through 911 or a local emergency telephone number. It is the fire department that usually has the training, equipment and knowledge to safely and effectively manage many of the large scale emergencies.

- Maintain readiness status for emergency notification.
- Participate in industrial operators' exercises where possible.
- Maintain 24 hour emergency contact numbers.

During the Incident

Local authorities, provincial or federal departments and agencies (including E911 centres and first responders) which become aware of an event that either has, or could, result in a major emergency or disaster, shall notify the EMO as soon as possible, by calling the **EMO Duty Officer 24/7 at 204-945-5555**.

Any emergency that has resulted, or may result in:

- Death or injury to multiple persons.
- Significant damage to:
 - Multiple properties,
 - Critical infrastructure,
 - The environment,
 - The economy, or
- Any emergency which is likely to overwhelm local resources.
- Any emergency which may require Provincial or Federal assistance (other than specialist resources that are provided in the ordinary course).

RCMP

- Advise local authorities respecting the maintenance of law and order.
- Provide security control of the emergency operations area(s).
- Provide security control of evacuated area(s).
- Provide traffic and crowd control.
- Administer public access and egress system within the flood plain and community ring dikes, in cooperation with the Departments of Conservation, Transportation and Infrastructure, and Water Stewardship.
- Assist the Chief Medical Examiner.
- Conduct search and rescue of missing persons.
- Coordinate forced evacuations.
- Maintain law and order and assist the operator with local security but would require discussion with the local police at the time.
- Assist with mobilization of additional resources.
- Typically would not be involved in setting up or maintaining roadblocks unless the emergencies impacted or required the closure of 1, 2 and 3 digit Provincial or Secondary highways.
- Establish and maintain communications with industrial operator.
- Dispatch a representative to the off-site Regional Emergency Operations Centre, when established, to coordinate the response.
- Coordinate with the industrial operator both the establishment and the administration of reception centres for evacuees.
- RCMP or local police would also become involved if there are fatalities as they are required to participate in the investigations. This could be through the medical examiner.
- The Office of the Fire Commissioner (OFC) has a working relationship with the RCMP and the RCMP may conduct selected duties of the Fire Commissioner where the fire's impact is not significant.
- Maintain a 24 hour emergency contact number where resources can be accessed for a response related to Emergency Response Plans.

Fire

- Respond to and assess emergency incident to the scope of their abilities.
- Establish a unified OSCP / ICP (On-site Command Post / Incident Command Post).
- Communicate to MEOC and provide site reps as required.
- Assist with fire protection where trained personnel are available.
- Provide emergency medical assistance, as required.
- Coordinate news releases with the licensee, if required.
- Provide response to dangerous goods incidents.
- By special order issued by the Minister responsible for this act (Emergency Medical Response and Stretcher Transportation), fire department personnel **MAY** operate an ambulance at the scene of an emergency incident when requested to do so by the EMS attendant(s), providing that the municipal fire fighter(s) possess the required Class 4 drivers license.

EMS

- Respond to and assess emergency incident to the scope of their abilities.
- Provides situational awareness and coordinates resources through the PREOCs and PECC.
- Provide emergency medical assistance, as required.
- Establish Incident Command.
- Provide first aid on site.
- Initiate health mutual aid if necessary.
- Log all actions and decisions.

After the Incident

- Complete a "lessons learned" process based on the scope of involvement and provide any feedback to the industrial operator.
- Participate in multi-agency debriefings.

*Regional Health Authority

- The regional health authorities are responsible within the context of broad provincial policy direction, for assessing and prioritizing needs and health goals, and developing and managing an integrated approach to their own health care system.
- Land ambulance services are delivered by a combination of providers including the Regional Health Authorities and other service providers under an agreement with regional health authorities (e.g., municipalities, First Nation communities).
- The air ambulance service providers include the provincial Lifeflight program (specialized air ambulance services operated provincially) and private air ambulance providers (basic air ambulance services).

- Provide representation at the off-site REOC or at the GEOC when established, if requested and if available.
- Provide accurate information to the public concerning the incident.
- Provide guidance and assistance at evacuation centre(s).
- Provide health related information about toxic chemicals and by-products.
- Provide guidance on public health advisories, public evacuation and sheltering.
- Provide guidance on rescinding a declaration of public evacuation and on allowing re-occupancy.
- Investigate health complaints from the public.
- Provide advice to the government GEOC and to the REOC on existing or potential health effects associated with the incident where possible.
- Provide health advice and safety levels for any health or special care facilities and for other persons that are likely to be sensitive from the impact as a result of the incident.
- Ensure local hospitals are alerted when there is potential for an impact from a release.
- Coordinate the provision of medical services during an emergency.
- Where appropriate and necessary, can declare a Local State of Public Health Emergency.
- When possible work with all other responders to establish a single Regional Emergency Operations Centre (REOC).

- Compile and maintain health related records and logs.
- Complete a "lessons learned" process based on the scope of involvement and provide any feedback to the industrial operator.
- Participate, where possible, in event debriefings.
- Complete incident related reports.
- Provide guidance on assessing and mitigating public health risks due to any residual environmental contamination following an event.

Roles and Responsibilities

North Dakota Industrial Commission (NDIC)	<p>The Oil and Gas Division regulates the drilling and production of oil and gas in North Dakota. Their mission is to encourage and promote the development, production, and utilization of oil and gas in the state in such a manner as will prevent waste, maximize economic recovery, and fully protect the correlative rights of all owners.</p> <p>https://www.dmr.nd.gov/oilgas/</p>
North Dakota Department of Health (NDDoH)	<p>North Dakota's public health system is decentralized with 28 independent local public health units working in partnership with the North Dakota Department of Health. The 28 local public health units are organized into single or multi-county health districts, city/county health departments or city/county health districts. The units are required to meet state standards and follow state laws and regulations, but they can exercise their own powers and have administrative authority to make decisions to meet their local needs.</p> <p>Local public health units - https://www.ndhealth.gov/localhd/</p>
North Dakota Department of Environmental Quality (NDDEQ)	<p>The Department of Environmental Quality is responsible for safeguarding North Dakota's air, land, and water resources. In cooperation with the general public, industry, and government at all levels, the section implements protective programs and standards to help maintain and improve environmental quality.</p> <p>Some releases may require immediate response by trained emergency personnel. This will be coordinated through the Department of Health, Division of Emergency Management and any other state or local emergency response agencies that may be needed.</p> <p>https://deq.nd.gov/WQ/4_spill_Investigations/IncidentReporting.aspx</p>
North Dakota Department of Emergency Services (NDES)	<p>NDES provides 24/7 emergency communications and resource coordination with more than 50 lead and support agencies, private enterprise, and voluntary organizations to assist local jurisdictions in disaster and emergency response activities. It administers federal disaster recovery programs and the Homeland Security Grant Program. NDES also manages the Emergency Management Assistance Compact (EMAC) that serves as a national clearinghouse through which member states may request and provide mutual aid assistance.</p> <p>The Division of State Radio coordinates 9-1-1 services as well as emergency medical, fire, and law enforcement response for twenty-five North Dakota counties and is the designated back-up for eight of the other public service answering points throughout the state, serving as secondary backup for an additional eight. State Radio is the primary dispatch center for the N.D. Highway Patrol, Game and Fish, various other state and federal agencies, and also responds to calls for emergency assistance across the state.</p> <p>https://www.nd.gov/des/</p>
County & Tribal Emergency Management	<p>Local and tribal governments maintain direct responsibility for initial response to incidents, emergencies, disasters, or catastrophes. Local emergency managers serve a key role in coordinating response and recovery efforts by providing situational awareness and accompanying resource requirements. NDES supports response and recovery coordination with emergency managers in each county and tribal nation within the state of North Dakota as well as the cities of Bismarck and Fargo.</p> <p>https://www.nd.gov/des/emergency/</p>

Note: Federal agencies such as the Environmental Protection Agency, Occupational Health & Safety Administration, and Bureau of Land Management have regional offices who have jurisdiction and responsibility for the execution of agency programs.



Roles and Responsibilities

State Agency Roles

The NDDOT is an innovative and progressive organization that has a great team of employees that work hard across the state to carry out the Department's mission to safely move people and goods.

The NDDOT strives to build and maintain an efficient transportation system consisting of about 8,518 miles of roadway and 4,858 bridges. It oversees the development of surface transportation including highways, bridges, rail, transit, pedestrian and bicycle paths across the state.

Local Government is the liaison between the Federal Highway Administration, LPA officials, and NDDOT divisions and districts and coordinates the Emergency Relief program on a statewide basis on behalf of the NDDOT.

<http://www.dot.nd.gov/>

NDDOT

The Boiler Inspection Program provides initial and periodic inspections of boilers of all sizes, types and pressures. Originated in 1953, the Boiler Inspection Program is responsible for the inspection and safe repair of boilers installed in public and commercial locations. Technical advice and engineering assistance are provided to installers, repair firms, operators and owner/users.

<https://www.deq.nd.gov/Director/BIP/>

NDDEQ - Boiler Inspection Program

North Dakota Workforce Safety & Insurance is the sole provider and administrator of the workers' compensation system and consists of Administrative Services, Employer Services, and Injury Services.

They also assist employers with safety and loss prevention program design, implementation and training; conducts workplace safety inspections; and investigates industrial accidents.

<https://www.workforcesafety.com/>

WSI

The State Emergency Response Commission (SERC) serves as the administering body for the N.D. Hazardous Chemicals Preparedness and Response Program with the Director of the N.D. Division of Homeland Security (NDHLS) serving as the SERC chairman. The SERC is responsible to provide coordination and oversight to the LEPCs. Additionally, the SERC is responsible to provide planning, training, exercising, and operational support to LEPCs.

<https://www.des.nd.gov/response-section/state-emergency-response-commission-serc>

SERC

Each county in North Dakota has been designated as a planning district with a Local Emergency Planning Committee (LEPC) appointed for each district. The LEPC is required to develop and maintain hazardous chemicals and emergency response plans for the respective district using information from facilities required to report under the "Right-to-Know" section of EPCRA. If a facility has a response plan of its own, appropriate information should be incorporated into the LEPC plan. Each Local Emergency Manager is a member of their respective LEPC and will coordinate local emergency planning and operational response activities regarding all hazards (including hazardous materials). Neither the Emergency Manager nor LEPC direct the actual response. That is almost always a fire department or law enforcement responsibility.

<https://www.des.nd.gov/response-section/state-emergency-response-commission-serc>

LEPC



Government Consultation Summary



Type of Agency	Agency Name	Provided Specific Roles	Agreed to Generic Roles	Unable to Contact	Willing to consider a single REOC	Evacuation outside of the EPZ	Location of EOC	Suggested Reception Centres	Notes
Health Authority	Saskatchewan Health Authority (SHA)		X		Yes	No	Any SHA facility	None	
Health Authority	Manitoba Health Authority (MHA) Prairie Mountain Health	X			Yes	No	Virtual	None	
Local Authority	R.M. of Coalfields No. 4		X		Yes	With assistance	423 Main Street, Bienfait, SK	None	
Local Authority	R.M. of Storthoaks No. 31		X		Yes	With assistance	204 Railway Ave, Storthoaks, SK	Redvers Recreation Centre	
Local Authority	R.M. of Pipestone			X	-	-	-	-	
Local Authority	R.M. of Antler No. 33		X		No	With assistance	14 Larsen Road	None	

SASKATCHEWAN HEALTH AUTHORITY

Resources would be provided in support of a petroleum emergency on an “as available” basis and in accordance with Local Health Authority Policy.

Before the Event

- Maintain readiness status for emergency notification.
- Participate in licensee’s preparatory training and exercises where possible.
- Maintain 24 hour emergency contact numbers.

Upon the Notification of and during an Event

- When possible work with all other responders to establish a single Regional Emergency Operations Centre (REOC).
- Provide representation at the off-site REOC or at the Government Emergency Operations Centre (GEOC) when established, if requested and if available.
- Provide advice to the GEOC and to the REOC on existing or potential health effects associated with the incident where possible.
- Provide accurate information to the public concerning the incident in cooperation with the licensee.
- Provide guidance and assistance at evacuation centre(s), where possible.
- Provide health related information about toxic chemicals and by-products, where possible.
- Provide guidance on public health advisories, public evacuation and sheltering.
- Investigate health complaints from the public.
- Provide health advice and safety levels for any health or special care facilities and for other persons that are likely to be sensitive from the impact as a result of the incident.
- Ensure local hospitals are alerted when there is potential for an impact from a release.
- Coordinate the provision of medical services during an emergency.
- Where appropriate and necessary, can declare a Local State of Public Health Emergency.

Regional Health Authority Representative will:

- Provide emergency medical services on site
- Advise Council through EOC Management Team on related public health issues.
- Log all actions.

After the Event

- Provide guidance on rescinding a declaration of public evacuation and on allowing re-occupancy.
- Compile and maintain health related records and logs.
- Participate, where possible, in event debriefings.
- Complete incident related reports.
- Provide guidance on assessing and mitigating public health risks due to any residual environmental contamination following an event.

LOCAL HEALTH AUTHORITY – PRAIRIE MOUNTAIN HEALTH

Resources would be provided in support of a petroleum emergency on an “as available” basis and in accordance with Local Health Authority Policy.

Before the Event

- The regional health authorities are responsible within the context of broad provincial policy direction, for assessing and prioritizing needs and health goals, and developing and managing an integrated approach to their own health care system.
- Land ambulance services are delivered by a combination of providers including the Regional Health Authorities. All land ambulance services are coordinated through the regional health authority (AKA SDO – Service Delivery Organization). There are no Municipal or First Nation ambulance providers within PMH.
- The air ambulance service providers include the provincial Lifeflight program (specialized air ambulance services operated provincially) and STARS air ambulance.
- Maintain readiness status for emergency notification.
- Participate in licensee’s preparatory training and exercises where possible.
- Maintain 24-hour emergency contact numbers.

Upon the Notification of and during an Event

- When possible, work with all other responders to establish a single Regional Emergency Operations Centre (REOC).
- Provide representation at the off-site REOC or at the Government Emergency Operations Centre (GEOC) when established, if requested and if available.
- Provide advice to the GEOC and to the REOC on existing or potential health effects associated with the incident where possible.
- Provide accurate information to the public concerning the incident.
- Provide guidance and assistance at evacuation centre(s).
- Provide health related information about toxic chemicals and by-products.
- Provide guidance on public health advisories, public evacuation and sheltering.
- Investigate health complaints from the public.
- Provide health advice and safety levels for any health or special care facilities and for other persons that are likely to be sensitive from the impact as a result of the incident.
- Ensure local hospitals are alerted when there is potential for an impact from a release.
- Coordinate the provision of medical services during an emergency.
- Where appropriate and necessary, can declare a Local State of Public Health Emergency.

Regional Health Authority Representative will:

- Provide emergency medical services on site. Onsite medical services are provided via Shared Health EMS and are not done by the RHA.
- Advise Council through EOC Management Team on related public health issues.
- Log and maintain all actions and responsibilities.

After the Event

- Provide guidance on rescinding a declaration of public evacuation and on allowing re-occupancy.
- Compile and maintain health related records and logs.
- Participate, where possible, in event debriefings.
- Complete incident related reports.
- Provide guidance on assessing and mitigating public health risks due to any residual environmental contamination following an event.

LOCAL AUTHORITY – R.M Coalfields No.4

(County / MD / ID / SA / City / Town / Village / First Nations)

Resources would be provided in support of a petroleum emergency on an “as available” basis and in accordance with Local Authority Policy.

Before the Event

- Maintain 24 hour emergency contact numbers.

Upon the Notification of and during an Event

- Respond to and assess the emergency incident with the licensee.
- Establish contact with the licensee in order to obtain emergency status information such as:
 - Additional hazard information
 - Roadblock locations and if assistance is required to set up and maintain
 - Direction of approach to the incident
 - Determine the extent of any injuries.
 - Find out what response and public protection actions have been taken
 - The location of the On-site Command Post (OSCP) and any Emergency Operations Centres (EOCs).
- When possible work with all other responders to establish a single Regional EOC (REOC) or have a representative present at the licensee’s EOC.
- If necessary, declare a State of Local Emergency.
- Activate the emergency public warning system to alert people to life threatening hazards, as required.
- Initiate public protection measures, as necessary.
- The licensee will coordinate notification and shelter in place or evacuation within the Emergency Planning Zone (EPZ). If the hazard area extends beyond the EPZ, the county will coordinate, with the licensee; evacuation of the public.
- Coordinate with the licensee establishment and maintenance of reception centre(s).
- Establish a public information service, including the use of the news media to inform and instruct the public of the emergency and of any protective actions to be taken.

After the Event

- Complete a “lessons learned” process and provide any feedback to the licensee.
- Participate in multi-agency debriefings.

Emergency Services (as managed / operated by the Local Authority)

Emergency Services will also, as a general rule, provide resources in support of a petroleum incident, on an “as available” basis.

Before the Event

- Maintain readiness status for emergency notification.

During the Event

- Respond to and assess emergency incident to the scope of their abilities.
- Establish a unified OSCP / ICP (On-site Command Post / Incident Command Post).
- Communicate to MEOC and provide site reps as required.
- Assist with fire protection, to scope of ability where trained personnel are available.
- Provide emergency medical assistance, as required.
- Coordinate news releases with the licensee, if required.

After the Event

- Complete a “lessons learned” process and provide any feedback to the licensee.
- Participate in multi-agency debriefings.

LOCAL AUTHORITY - R.M. of STORTHOAKS NO. 31

(County / MD / ID / RM / SA / City / Town / Village / First Nations)

Resources would be provided in support of a petroleum emergency on an “as available” basis and in accordance with Local Authority Policy.

Before the Event

- Maintain 24 hour emergency contact numbers.

Upon the Notification of and during an Event

- Respond to and assess the emergency incident with the licensee.
- Establish contact with the licensee in order to obtain emergency status information such as:
 - Additional hazard information
 - Roadblock locations and if assistance is required to set up and maintain
 - Direction of approach to the incident
 - Determine the extent of any injuries.
 - Find out what response and public protection actions have been taken
 - The location of the On-site Command Post (OSCP) and any Emergency Operations Centres (EOCs).
- Activate the Municipal Emergency Plan (MEP) and establish a Municipal Emergency Operations Centre (MEOC) if required.
- When possible work with all other responders to establish a single Regional EOC (REOC) or have a representative present at the licensee’s EOC.
- The licensee will coordinate notification and shelter in place or evacuation within the Emergency Planning Zone (EPZ). If the hazard area extends beyond the EPZ, the municipality will coordinate, with assistance from the licensee; evacuation of the public.
- Coordinate with the licensee establishment and maintenance of reception centre(s).

After the Event

- Complete a “lessons learned” process and provide any feedback to the licensee.
- Participate in multi-agency debriefings.

Emergency Services (as managed / operated by the Rural Municipality)

Emergency Services will also, as a general rule, provide resources in support of a petroleum incident, on an “as available” basis.

Before the Event

- Maintain readiness status for emergency notification.

During the Event

- Respond to and assess emergency incident to the scope of their abilities.
- Establish a unified OSCP / ICP (On-site Command Post / Incident Command Post).

P 403.212.2332 | F 403.313.9180 | E info@h2safety.ca
210, 7260 12 St. SE | Calgary, AB, T2H 2S5



- Communicate to MEOC and provide site reps as required.
- Assist with fire protection, to scope of ability where trained personnel are available.
- Provide emergency medical assistance, as required.

After the Event

- Complete a “lessons learned” process and provide any feedback to the licensee.
- Participate in multi-agency debriefings.

LOCAL AUTHORITY - R.M. of ANTLER NO. 61

(County / MD / ID / RM / SA / City / Town / Village / First Nations)

Resources would be provided in support of a petroleum emergency on an “as available” basis and in accordance with Local Authority Policy.

Before the Event

- Work with the licensee to effectively prepare for a petroleum industry incident. Provide input to the licensee’s site-specific plan to ensure it is compatible with the Municipal Emergency Plan (MEP) where feasible.
- Participate in licensee’s preparatory training and exercises where possible.
- Maintain 24 hour emergency contact numbers.

Upon the Notification of and during an Event

- Respond to and assess the emergency incident with the licensee.
- Establish contact with the licensee in order to obtain emergency status information such as:
 - Additional hazard information
 - Roadblock locations and if assistance is required to set up and maintain
 - Direction of approach to the incident
 - Determine the extent of any injuries.
 - Find out what response and public protection actions have been taken
 - The location of the On-site Command Post (OSCP) and any Emergency Operations Centres (EOCs).
- Activate the Municipal Emergency Plan (MEP) and establish a Municipal Emergency Operations Centre (MEOC) if required.
- When possible work with all other responders to establish a single Regional EOC (REOC) or have a representative present at the licensee’s EOC.
- If necessary, declare a State of Local Emergency.
- Activate the emergency public warning system to alert people to life threatening hazards, as required.
- Initiate public protection measures, as necessary.
- The licensee will coordinate notification and shelter in place or evacuation within the Emergency Planning Zone (EPZ). If the hazard area extends beyond the EPZ, the municipality will coordinate, with the licensee; evacuation of the public.
- Coordinate with the licensee establishment and maintenance of reception centre(s).
- Establish a public information service, including the use of the news media to inform and instruct the public of the emergency and of any protective actions to be taken.
- Coordinate news releases with the licensee, if required.

After the Event

- Complete a “lessons learned” process and provide any feedback to the licensee.
- Participate in multi-agency debriefings.

Emergency Services (as managed / operated by the Rural Municipality)

Emergency Services will also, as a general rule, provide resources in support of a petroleum incident, on an “as available” basis.

Before the Event

- Maintain readiness status for emergency notification.
- Participate in licensees’ exercises where possible.

During the Event

- Respond to and assess emergency incident to the scope of their abilities.
- Establish a unified OSCP / ICP (On-site Command Post / Incident Command Post).
- Communicate to MEOC and provide site reps as required.
- Assist with fire protection, to scope of ability where trained personnel are available.
- Provide emergency medical assistance, as required.
- Coordinate news releases with the licensee, if required.

After the Event

- Complete a “lessons learned” process and provide any feedback to the licensee.
- Participate in multi-agency debriefings.

	Before the Incident	During the Incident	After the Incident
Ministry Labour Relations & Workplace safety	<ul style="list-style-type: none"> □ This ministry works with employers and employees, as well as industry stakeholders to reduce and eliminate workplace injuries and create a safe work environment. □ Maintain 24 hour emergency contact number where resources can be accessed for reporting of serious injury or fatality. 	<ul style="list-style-type: none"> □ Dispatches representatives, when deemed appropriated, to evaluate and enforce compliance of regulations under provincial and territorial jurisdiction. □ Ensure that the company is monitoring the health and safety of all contractors and other workers who are not under the Canada Labour Code Jurisdiction. 	<ul style="list-style-type: none"> □ Will inspect and review the events of serious injuries or death to workers under provincial and territorial jurisdiction to ensure compliance with the provincial OHS legislation.
Ministry Highways	<ul style="list-style-type: none"> □ Ministry of Highways manages Saskatchewan's network of highways and infrastructure. □ Manages Saskatchewan's Highway Hotline, ensuring Saskatchewan people, the trucking industry, and visitors have information on highway construction, road closures, and road conditions. □ Maintain 24 hour emergency contact number where resources can be accessed for a response related to Emergency Response Plans. <p>Transportation Programs & Services</p> <ul style="list-style-type: none"> □ Manages Saskatchewan's regulated railway infrastructure, <i>The Railway Act</i> and reviews and authorizes construction/opening of provincially regulated railway. □ Maintains emergency contact information (Provincial Railway Inspector). □ May inspect all or any part of a railway and provide written report where the minister: <ul style="list-style-type: none"> □ Receives a complaint about the state of repair of any part of a railway. □ For any reason an inspection of a railway is necessary. □ May conduct audits of the facility and rail operations to ensure compliance with provincial regulations 	<ul style="list-style-type: none"> □ Provide authorization and assistance for establishing emergency roadblocks with company officials, local authorities and the RCMP. □ Provide assistance with the closure of provincial highways and the establishment of suitable detour routes. □ Provide advice and assistance with procurement of roadblock equipment. <p>Transportation Programs & Services</p> <ul style="list-style-type: none"> □ Provide authorization and assistance for the cancellation of services and closure of provincial railway infrastructure. □ Investigate incidents and can issue orders to rectify any deficiencies to bring provincially regulated railway into compliance. 	<ul style="list-style-type: none"> □ Work with appropriate local and federal entities to facilitate the restoration of roadways and utilities. <p>Transportation Programs & Services</p> <ul style="list-style-type: none"> □ Accidents and incidents will be investigated as required by Rail Services pursuant to Section 32 of <i>The Railway Act</i>. Accident/Incidents must be reported following the provincial guideline PRG 1006. □ Work with appropriate local and federal entities to facilitate the restoration of provincial railway infrastructure.
Ministry of Health	<p>The Ministry of Health (MoH) and the Saskatchewan Health Authority (SHA) have interdependent roles and responsibilities. Both are involved in meeting expectations in relation to the following key areas:</p> <ul style="list-style-type: none"> □ Strategic planning □ Fiscal management and reporting □ Relationships □ Quality management □ Monitoring, evaluation and reporting □ Management and performance 	<ul style="list-style-type: none"> □ Provide an effective and timely response to major health events, emergencies and disasters regardless of their cause. □ Provide timely health information including warnings, health risks, prevention and other information to the public, media and stakeholders. □ Ensuring continuity of healthcare services thereby maximizing health outcomes in the Province of Saskatchewan in the event of an emergency or disaster, including ensuring that essential laboratory services are maintained. □ Liaise with other ministries, provincial, federal, international government agencies and community-based organizations, including provision of resources and subject matter experts, depending on the nature of the emergency. □ Provide direct delivery of services and supplies, depending on nature of the emergency. □ Establish and advise on health and safety levels for the escaping of contaminant and remedial measures. □ Consult with applicable environmental protection agencies to provide advice on existing and potential health effects of the incident. 	<ul style="list-style-type: none"> □ The MoH and SHA conduct After Action review operations and lessons learned to enhance emergency preparedness and response plans for future incidents. □ Ensure appropriate data is collected to monitor the health effects of the incident. □ Recommend further investigation or research after the event is warranted.
Technical Safety Authority	<ul style="list-style-type: none"> □ Review, accept and register pressure equipment designs and construction procedures that relate to pressure equipment. □ Issue certificate of inspection permits for pressure equipment before the equipment is placed into service. □ Ensure that regular inspections of in-service pressure equipment are conducted. □ Keep records for pressure equipment that has been registered for use, or manufactured, in Saskatchewan. □ Examine, certify and register Pressure Welders and Welding Examiners, Power Engineers, and Pressure Equipment Inspectors. □ Conduct safety education and training. 	<ul style="list-style-type: none"> □ Receive notification of an incident involving a Boiler, Pressure Vessel, Elevator or Amusement Ride in Saskatchewan. 	<ul style="list-style-type: none"> □ Investigate accidents or unsafe conditions that involve boilers or pressure equipment.
SaskPower Electrical Safety	<ul style="list-style-type: none"> □ SaskPower generates safe, reliable and sustainable power for the people of Saskatchewan. □ SaskPower is the principal electric utility in Saskatchewan, Canada. 	<ul style="list-style-type: none"> □ SaskPower would disconnect electrical services for residents that would be affected by flooding to ensure safety. 	<ul style="list-style-type: none"> □ SaskPower would be present in mobile command posts to assist residents with the safe restoration of electricity as quickly as possible.
SaskEnergy	<ul style="list-style-type: none"> □ SaskEnergy delivers the benefits of safe, convenient and environmentally friendly natural gas to nearly 400,000 residential, farm, commercial and industrial customers throughout Saskatchewan. □ Purchase natural gas from independent suppliers and transport it through our over 15,000 kilometres of transmission pipelines and more than 71,000 kilometres of distribution lines to serve 93% of Saskatchewan communities. 	<ul style="list-style-type: none"> □ SaskEnergy would determine the appropriate course of action depending on the type and extent of emergency at the time, which in some cases may result in loss of natural gas service. 	<ul style="list-style-type: none"> □ If required, customers are to arrange with SaskEnergy to have natural gas service turned back on.

Supporting Agency Roles

Supporting Agency Roles

Workers' Compensation Board Ministry of Agriculture

Before the Incident

The WCB is the provincial agency that delivers workplace insurance to Saskatchewan employers and benefits to Saskatchewan workers when they are hurt at work.

The *Workers' Compensation Act, 2013*, together with the General Regulations and Exclusions, make up the laws under which the Saskatchewan Workers' Compensation Board operates.

- Provide registered employers with workplace insurance coverage.
- Assess fair premiums.
- Educate employers and workers about injury prevention through WorkSafe Saskatchewan and the WCB's Prevention department.
- Help employers develop and implement safety and prevention programs.
- Support research to prevent and reduce injuries and occupational diseases.

An agricultural industry emergency will be defined according to the following:

- There is an imminent threat to livestock, public safety, personal property, the food chain or the environment.
- There is irrevocable harm.
- An epidemic with the potential to spread.
- When the cost of stopping the event is less than the cost of not doing anything.
- Incursion of a foreign or emerging animal disease that can be of economic or public health significance or acts of bio or agro terrorism.

During the Incident

Employer must contact the WCB within 5 days after the date on which they've become aware of an injury that prevents a worker from earning full wages or that necessitates medical aid. The employer shall notify the board in writing of:

- The nature, cause and circumstances of the injury.
- The time of the injury.
- The name and address of the injured worker.
- The place where the injury happened.
- The name and address of any physician who attends the worker for his or her injury.
- Any further particulars of the injury or claim for compensation that the board may require.

- Provides advice and assistance in relation to agricultural matters.
- Provides veterinary guidance.
- Provides plant and animal health advice.
- Arranges emergency evacuation and rescue.
- Coordinates livestock feeding services in the event of an emergency.
- Operates under the Terrestrial Animal Disease Emergency Support (TADES), in coordination with federal agencies.

After the Incident

- Determine and provide WCB benefits to injured workers.
- Provide case management services to facilitate health care and monitor workers' recovery and return to work.
- Help employers and workers develop and implement workplace return-to-work programs and individual return-to-work plans to accommodate injured workers, as required by law.
- Coordinate vocational services to injured workers if required.
- Interview any person who they believe can provide information about a work related fatality, serious injury or allegation of harassment.

- The EPO will initiate a debriefing of any emergency situations.
- Updating and approval will occur in the following circumstances:
 - Update the plan after a debriefing.
 - Update the plan after a test of the plan.
 - Update the appendices once a year.
 - Update the plan at least once a year.
 - EPO will initiate any plan reviews.
 - Ministry Emergency Management Team updates the plan.
 - Deputy Minister communicates the plan to staff through the directors.
 - EPO to communicate plan to Emergency Management & Fire Safety.
 - Plan posted on the Ministry's website (without the phone numbers of staff).

Before the Incident

- Promote methods of fire prevention and public safety.
- Collect and disseminate information and statistics about fires.
- Give advice and assistance to local authorities about emergency response and fire protection services, including training of persons who provide those services.
 - Equipment and adequate water supply for emergency response and fire protection services, and
 - By-laws and agreements respecting emergency response and
- Provide critical incident stress management for emergency response personnel and provide and coordinate resources used for search and rescue.
- Establish an incident management system for directing and managing emergency response services at the site of an emergency or disaster.
- Issue directives about how to dispose of combustibles and explosive materials or other things that may constitute a fire menace.
- Provides emergency response services on behalf of the province of Manitoba.

- When necessary, specialized expertise from any of the Department's program areas may be called out to assist in the response to an environmental accident. The response team has access to all of the resources of the provincial government and, through agreement, the resources of the federal government as well.
- The Manitoba Emergency Plan identifies Manitoba Environment, Climate and Parks as the lead provincial agency for dangerous goods incidents.
- Provide advice and assistance in waste disposal.

- Manitoba Public Health aims to provide the leadership and coordination for an integrated approach to public health programs and services.
- The core functions of public health are population health assessment, health surveillance, disease, injury prevention, health promotion and health protection.
- To focus on the prevention and control of diseases and the promotion of health.
- Liaise, collaborate and coordinate on health-related matters with all federal and provincial agencies.
- Ensure continuity of care at health care organizations providing health services that are the responsibility of Manitoba Health.

During the Incident

- Monitors emergency incidents throughout the province.
- The Fire Commissioner has the authority to exercise certain powers at the scene of an emergency or disaster if deemed necessary to meet the needs of the emergency and to eliminate or reduce its effect.
- Order the evacuation of land or premises, and / or calling on peace officers or a police force to assist with an evacuation.
- Provide an Incident Commander during the response phase of an emergency if it has been determined that an adequate Incident Command system may not be in place at a particular site or location.
- Provide on-site technical advice and / or assistance to municipal fire services.
- Provide and coordinate rescue activities and resources during a provincial emergency.
- Provide assistance to fire Mutual Aid Coordinators respecting municipal fire services emergency response.
- Provide logistical support to the RCMP for provincial ground search and rescue and clandestine drug operations.
- Provide building / structure safety inspection services.
- Coordinate and / or provide fire protection for communities during Department of Conservation Fire Program forest fires.
- Coordinate the Provincial Volunteer Ground Search and Rescue (GSAR) network.
- Operate the Provincial Urban Search and Rescue (USAR)
- Coordinate 3 Hazardous Materials Technician response teams (CBRN):
 - Chemical, Biological, and Radiological & Nuclear

General

- Provide support to regulatory enforcement services.
- Provide supplementary emergency radio communication.
- Provide specialized transportation equipment and operations, e.g., ATVs, snowmobiles, boats and bombardiers.
- Assist in acquiring helicopter / aircraft resources.
- Assist the Office of the Fire Commissioner in search and rescue operations.
- Administer public access and egress systems within the flood plain and community rink dikes, in cooperation with Transportation and Infrastructure, Water Stewardship, and Justice.
- Provide other regional resource, staff, equipment, and infrastructure in support of emergency operations.

Fire

- Direct forest fire operations.
- Provide forest fire fighting equipment.
- Provide technical advice and assistance to other departments and local authorities about forest fire operations.

Environmental Emergency Response Program

- Operates within the mandates of *The Dangerous Goods Handling and Transportation Act* and *The Environment Act*. This Act gives Environment Officers and Inspectors special powers in emergencies to enter any land or building, control and clean up releases and take any emergency actions required to protect persons, property and the environment.
- The Emergency Response Team responds to releases or potential releases of contaminants that may have a detrimental effect on the physical environment or public health.
- Direct the on-site response to environmental accidents.
- Oversee operations for contaminant monitoring and analysis.
- Direct environmental accident spill control, clean-up operations, and disposal arrangements.
- Arrange for the provision of technical personnel and equipment resources in support of law enforcement for dealing with Clandestine Drug Labs and as part of the provincial Chemical, Biological, Radiological, Nuclear, and Explosive (CBRNE) Response Team.
- Provide technical environmental advice to local authorities, departments, and agencies.
- Provide advice on public protection measures (evacuation, shelter-in-place and reentry).
- Provide support to the Department of Water Stewardship - Office of Drinking Water by undertaking initial sampling, testing and assessment at the emergency site.
- Provide assistance in monitoring discharges and ensuring appropriate mitigation and response actions are taken to reduce the impact of liquid releases for land based spills and to ensure watercourses are protected.

Water Stewardship

- Coordinate, plan, and direct flood control operations.
- Plan collection of aerial photography and other aerial imagery.
- Plan ice jam mitigation program, and deploy ice jam mitigation equipment.
- Provide flood forecasting and monitoring services.
- Provide public information on flood forecasts, regulation of water control structures, and flood-related activities.
- Coordinate and provide provincial direction for the operation of flood control works (e.g. Red River Floodway, Portage Diversion).
- Administer public access and egress system within the flood plain and community ring dikes, in cooperation with the Departments of Conservation, Transportation and Infrastructure, and Justice.
- Coordinate with Transportation and Infrastructure in the distribution of sandbags, sandbagging equipment, and water barriers.
- Coordinate with Transportation and Infrastructure in the provision of engineering and technical advice and assistance to municipalities concerning flood protection measures.
- Provide advice to municipalities and Departments of Conservation, Transportation and Infrastructure on the most efficient and effective use of flood fighting resources.
- Provide permission to cut roads and create water diversions.

- Monitor and support Regional Health Authority (RHA) and health care organization emergency / disaster management activities.
- Evaluate the risk of negative health outcomes to the public.
- Provide information, advice and guidance to the public on health-related issues.
- Contribute health-related information to other sectors, organizations, and agencies.
- Secure, coordinate, and distribute necessary medical resources (e.g. human resources, supplies, vaccines, etc.) to support RHAs and health care organizations in response to the requirements of an emergency / disaster.
- Coordinate air ambulance evacuations (i.e. Lifeflight and basic air ambulance carriers) and ground medical evacuations.
- Coordinate the deployment of National Emergency Stockpile System (NESS) resources in Manitoba.
- Ensure the provision of institutional and community-based (public) health services in response to community needs during and immediately after an emergency / disaster.
- Support RHAs and health care organizations in the coordination of evacuations of health care facilities as required.
- Assign liaison officers and / or on-site response personnel to support RHAs and health care organizations as required.

After the Incident

- Fire investigators work closely with law enforcement to determine the cause and origin of every fire in Manitoba.
- Information gathered at the fire scene is compiled and used to design fire and life safety programs for target groups and to reduce fire loss across Manitoba.
- Complete a "lessons learned" process based on the scope of involvement and provide any feedback to the industrial operator.
- Participate in multi-agency debriefings.

- Complete a "lessons learned" process based on the scope of involvement and provide any feedback to the industrial operator.
- Participate in multi-agency debriefings.

Environmental Emergency Response Program

- Participate in the evaluation of the incident and the potential area at risk from product releases.

- Assist with the investigation of incidents that result in serious injuries or death to workers under provincial and territorial jurisdiction.
- Complete a "lessons learned" process based on the scope of involvement and provide any feedback to the industrial operator.
- Participate in multi-agency debriefings.

Supporting Agency Roles



Manitoba
Hydro

*ITS

*MoA

*WS&H

Manitoba Transportation and Infrastructure

Before the Incident

- Development of transportation policy and legislation, and for the management of the province's vast infrastructure network.
- Responsibilities include corporate policy and provincial legislation development, motor carrier safety and regulation enforcement, carrier permits and the development and implementation of sustainable transportation initiatives.
- Delivery of several transportation and infrastructure-related services or programs such as air ambulance flights, water bomber operations, property management, procurement, material distribution, fleet vehicles, Crown Lands stewardship, mail management, and government building security across the province.

Engineering & Operations Division

- Provide a 24/7 highway information call centre and web page.
- Construct and maintain provincial roads, bridges, airports and water control infrastructures.
- Plan, direct, and coordinate all highway traffic functions.
- Plan, direct, and coordinate the use of northern airports and provincial resources.
- Coordinate with the Department of Water Stewardship in the provision of engineering and technical advice and assistance to municipalities concerning flood protection measures.
- Coordinate with the Department of Water Stewardship to collect hydrologic data for flood forecasting purposes.
- Coordinate with the Department of Water Stewardship to conduct groundwater monitoring and well protection programs.

Transportation Policy and Motor Carrier Division

- Determine routing and ensure compliance of heavy-lift trucking and movement of heavy equipment.
- Provide special transportation permits.

- Administer *The Workplace Safety and Health Act* and associated regulations that deal with the health and safety of workers
- Eliminate workplace and public hazards through preventative measures like education, training, cooperation, and inspections and investigations - all legislated by our provincial documents.
- Protection of Manitoba's workforce.

The Ministry of Agriculture works to accelerate the greater prosperity and capacity of agricultural producers and industry, food processors, other rural entrepreneurs, organizations as well as rural and northern communities.

- Provides electricity and gas service to communities throughout the province.

- Boiler, pressure vessel and refrigeration plant inspections.
- Gas and oil-fired equipment inspections and permits.
- Electrical application inspections.
- Elevator and amusement ride inspections.
- Licensing of power engineers, welders, gas fitters and electricians.
- Quality assurance reviews of certain engineering plans and decisions.
- Quality assurance program reviews for pressure equipment, pressure piping manufacturing and installation.

- Employer must report worker injuries to the WCB within 5 days from the day the worker reported it to them, or from the day the employer first learns of it, whichever is earlier.
- WCB will adjudicate the claim to determine if the injury arose out of and in the course of employment.
- WCB will provide benefits to which the worker is entitled under *The Workers Compensation Act*.

During the Incident

Vehicle Equipment Management Agency (VEMA)

- Provide and service light vehicles necessary to the emergency response through Fleet Vehicles Agency.
- Provide and service radios necessary to the emergency response through Radio Services.
- Provide and service heavy equipment / vehicles necessary to emergency response through Mechanical Equipment Services.

Materials Distribution Agency (MDA)

- Provide office furniture; home care supplies / equipment; and personal care, janitorial and stationery supplies as necessary to the emergency response.
- Provide material support services.
- Arrange and provide transportation support for the movement of emergency equipment and supplies.
- Provide emergency postal services.

Procurement Services Branch (PSB)

- Provide emergency purchasing services.

Air Services

- Coordinate Life Flight and Medevac flights on a 24-hour basis utilizing government aircraft and commercial charter on an as required basis.
- Provide government aircraft for conservation of forest and other natural resources of the province and / or jurisdictions.
- Provide coordination and certification to all government clients with air charter travel arrangements using government aircraft and commercial carriers.
- Provide monitoring of all Air Services Flights.
- Provide aviation supports to all Manitoba Government departments, agencies and crown corporations.
- Plan, acquire, direct and control the use of all air transportation resources.

Accommodation Services Division

- Assist College authorities in college emergency closing and re-opening.
- Coordinate use of government buildings for short term emergency housing.
- Liaise with universities with regards to emergency housing.
- Provide access to and security of the Manitoba Emergency Coordination Centre (MECC).
- Coordinate security services for other government facilities necessary to the emergency response.
- Coordinate the acquisition of commercial rental space for emergency facilities or accommodation.

Engineering & Operations Division

- Construct temporary roads and bridges for emergency access to affected locations.
- Arrange for emergency repair of damaged provincial roads, bridges, airports, and water control infrastructures.
- Coordinate with Department of Water Stewardship to prepare, haul and provide sandbags, sandbagging equipment, and water barriers.
- Acquire, receive, issue and account for emergency supplies and equipment.
- Operate and maintain flood control works, under the direction of Water Stewardship.
- Administer public access and egress system within the flood plain and community ring dikes, in cooperation with the Departments of Water Stewardship, Conservation, and Justice.
- Plan, acquire, direct and control the use of fleet-net radio, sat phones, and equipment resources.

Transportation Policy and Motor Carrier Division

- Assist in law enforcement situations.

- Secure workers and self-employed persons from risks to their safety, health and welfare arising out of, or in connection with, activities in an emergency response.
- Protect other persons from risks to their safety and health arising out of, or in connection with, an emergency response.
- Provide electrical / mechanical inspection services.

- Coordinate and lead on agricultural and food supply matters, including:
 - Arrange for the provision of emergency veterinary services as per *The Animal Care Act*.
 - Undertake arrangements for emergency evacuation and / or feeding of livestock.
 - Support agencies dealing with the rescue and care of companion and hobby farm animals in affected or evacuated areas.
 - Undertake arrangements for emergency evacuation of farm stored grains, fertilizer, pesticides, and other chemicals.
 - Take the provincial lead in an animal health incident or outbreak.
- Facilitate farm and rural stress response during an emergency.

- Assure a continued supply of electrical energy and natural gas under emergency conditions.
- Provide temporary electrical or natural gas service when and where necessary for emergency operations.
- Protect Manitoba Hydro Installations.
- Interrupt electrical or natural gas service for protection of life and property.
- Advise and assist departments and local authorities with respect to emergency electrical or natural gas service.

- Receive notification of an incident involving a Boiler, Pressure Vessel, Elevator or Amusement Ride

After the Incident

- Complete a "lessons learned" process based on the scope of involvement and provide any feedback to the industrial operator.
- Participate in multi-agency debriefings.

- Compile and maintain health and safety related records and logs.
- Monitor lease holder / contractor plans to determine if site is safe for recovery workers
- Investigate non-compliance with the *The Workplace Safety and Health Act*. The investigations may be coordinated with, or independent of, any other investigation in relation to the incident.

- Complete a "lessons learned" process based on the scope of involvement and provide any feedback to the industrial operator.
- Participate in multi-agency debriefings.

- Complete a "lessons learned" process based on the scope of involvement and provide any feedback to the industrial operator.
- Participate in multi-agency debriefings.

- Investigate accidents or unsafe conditions that involve boilers or pressure equipment.

- Assist the worker to access treatment for his or her recovery and safe return to work.

Before the Incident

During the Incident

After the Incident

*ECCC

Environment & Climate Change Canada's Environmental Emergencies Program (EEP) protects Canadians and their environment from the effects of environmental emergencies through provision of science-based expert advice and regulations. The key Acts and Regulations that govern ECCC's role in environmental emergencies that allow it to deliver its mandate are:

- Canadian Environmental Protection Act, 1999
- Fisheries Act—Pollution Prevention Provisions;
- Migratory Birds Convention Act, 1994;
- Statutory Notification Requirements—EC's Environmental Notification System.
- Environmental Emergencies Regulations.

*DFO

The Canadian Coast Guard is the lead federal agency for ensuring appropriate response to all ship-source and unknown mystery spills in Canadian waters and waters under international agreements.

- Establishes appropriate and nationally consistent level of preparedness and response services in Canadian waters.
- Design and develop related regulations, policies, strategies and tools.
- Review, assess and monitor activities associated with fish habitat to ensure their compliance with the Fisheries Act and Species at Risk Act.
- Conduct environmental assessments under the Canadian Environmental Assessment Act.
- Design, develop and implement communication and education strategies.

NAV
Canada

NAV Canada is a private company who coordinates the safe and efficient movement of aircraft in Canadian domestic airspace and international airspace assigned to Canadian control.

Flight Information Centre (FIC) – FIC Services
Each Flight Information Centre is responsible for providing its particular service area with the following services, which pilots rely upon for safe flight planning and operations:

- Emergency
- Aviation Weather Briefing
- Flight Planning
- En-route Flight Information Services
- Remote Aerodrome Advisory Services (RAAS)

Health
Canada

- Sets national standards to keep the environment healthy, keep water and air pollution low and Canadians safe.
- Maintains a nationwide network of radiation monitoring stations and can act if levels spike.
- Under Chemicals Management Plan, assess health risks from chemicals used in manufacturing and agriculture and require users to prove they actually need the chemicals to make their products
- Sets strict rules on how chemicals are used in order to limit human exposure.
- Preparedness exercises are designed to test how well the plans and procedures work during simulated emergency situations. Such exercises help the government identify strengths as well as any problems or inadequacies in preparedness plans and procedures so that these can be addressed before, not after, an actual emergency.

Public Health
Agency of Canada

The Centre for Emergency Preparedness and Response (CEPR) is responsible for:

- Developing and maintaining national emergency response plans for the Public Health Agency of Canada and Health Canada.
- Assessing public health risks during emergencies.
- Contribution to keeping Canada's health and emergency policies in line by collaborating with other federal and international health and security agencies.
- The health authority in the Government of Canada on bioterrorism, emergency health services and emergency response.
- Strengthen intergovernmental collaboration on public health and facilitate national approaches to public health policy and planning.
- Manages emergency preparedness and emergency response plans and keeps them up to date.
- Develops and runs exercises to train emergency workers.
- Develops and delivers training courses that teach health workers how to respond to emergencies.

During an environmental emergency, *The National Environmental Emergencies Centre (NEEC)* is the focal point for ECCC.

ECCC's services during an environmental emergency:

- Collaborate with federal, provincial, territorial and international environmental protection agencies to enable rapid sharing of information.
- Convene and chair a Science Table of experts and stakeholders to develop consensus based advice to the Lead Agency.
- Identify environmentally sensitive areas and priorities (sensitivity and resource at risk mapping).
- Advise on mitigation and cleanup measures.
- Provide support and guidance in the assessment of oiled shorelines to prioritize their protection and cleanup (Shoreline Cleanup Assessment Technique (SCAT)).
- Advice on the fate and behavior of the spilled product.
- Advice on sampling and laboratory analysis.
- Provide weather forecasting and spill dispersion modelling to identify where these substances are likely to move in the environment.
- Provided expertise on the migratory bird resources and species at risk, including on-site assessment and determination of wildlife impact.
- Can conduct post-emergency assessments.

- Any amount of hydrocarbons entering a waterway frequented by fish or occupied by waterfowl is deemed to be in contravention of the Federal Fisheries Act and must be reported to the Department of Fisheries and Oceans.
- Work together with provincial environment protection agencies and may be initially notified by ECCC.
- May send personnel to the site if there has been or could potentially be an impact to fish or fish habitat.
- Monitors and investigates all reports of marine pollution in Canada in conjunction with other federal departments.
- Maintains communications with the program's partners, including Transport Canada and ECCC, to ensure a consistent coordinated approach to marine pollution incident response.
- Aids in search and rescue operations.

- As requested by the oil and gas company, the Flight Information Centre will issue a NOTAM (Notice to Airmen).
- To close air space beyond an airport (e.g. above a sour gas release), Refer to Transport Canada on back side of this page.

- During a health emergency or disaster, Health Canada and the Public Health Agency of Canada are responsible for supporting emergency health and social services in the provinces and territories.

- In an emergency situation, the Office of Emergency Response Services (OERS) is responsible for supporting emergency health and social services in the provinces, territories or abroad. It manages the National Emergency Stockpile System (NESS), which includes medical, pharmaceutical and related emergency supplies. The Office is responsible for the federal response to emergencies that have health repercussions; this includes the deployment of health emergency response teams (HERT).
- If a public health emergency grows beyond one province and/or territory, the Public Health Agency of Canada usually gets involved.

- ECCC can conduct post-emergency assessments.
- Provide specialized advice in shoreline clean-up assessment techniques (SCAT).
- Provide Advise on mitigation and cleanup measures..

- Work closely with ECCC, The Canadian Coast Guard and other provincial environmental agencies.

- Rescind the NOTAM.

- Work collaboratively with the provinces and territories to test ways in which the Canadian health care system can be improved and ensure its sustainability for the future.

- Work with Health Canada to test ways in which the Canadian health care system can be improved and ensure its sustainability for the future.

Federal Agency Roles

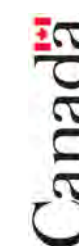

Federal Agency Roles



	Before the Incident	During the Incident	After the Incident
Transport Canada	<ul style="list-style-type: none"> ☐ Maintain a 24 hour emergency telephone service. <p>*CANUTEC</p> <ul style="list-style-type: none"> ☐ Regulate the handling, offering for transport and the transport of dangerous goods by all modes in order to ensure public safety. ☐ Federal regulations require that CANUTEC be contacted in the event of an incident or accident involving dangerous goods and infectious substances. ☐ Maintains records of over 3 million Safety Data Sheets (SDS). <p>Aviation Operations Centre (AVOPS)</p> <ul style="list-style-type: none"> ☐ Federal regulations require that AVOPS be contacted if there is imminent and immediate threat to aviation and public safety. 	<p>*CANUTEC</p> <ul style="list-style-type: none"> ☐ Assist emergency response personnel in handling dangerous good emergencies including advice on <ul style="list-style-type: none"> ☐ Chemical, physical and toxicological properties and incompatibilities of the dangerous goods ☐ Health hazards and first aid ☐ Fire, explosion, spill or leak hazards ☐ Remedial actions for the protection of life, property and the environment ☐ Evacuation distances ☐ Personal protective clothing and decontamination ☐ CANUTEC staff does not go to the site of an incident, however, should on-site assistance be required, CANUTEC can assist in the activation or industry emergency response plans. ☐ Provide communication links with the appropriate industry, government or medical specialists. <p>Aviation Operations Centre (AVOPS)</p> <ul style="list-style-type: none"> ☐ To close air space beyond an airport in a defined area (e.g. above a sour gas release), AVOPS can be contacted by the oil and gas company. 	<p>*CANUTEC</p> <ul style="list-style-type: none"> ☐ Maintain voice communication and written information records for two years for the protection of all parties. <p>Aviation Operations Centre (AVOPS)</p> <ul style="list-style-type: none"> ☐ Rescind the NOTAM and re-open air space that was closed due to emergency.
*PSC	<ul style="list-style-type: none"> ☐ Public Safety Canada works with provincial and territorial officials to ensure first responders and emergency management personnel are well-prepared through education, support and exercises. ☐ Responsible for promoting and coordinating the preparation of departmental emergency management plans as well as coordinating the government's response to an emergency through the Government Operations Centre (GOC). 	<ul style="list-style-type: none"> ☐ Public Safety Canada houses the Government Operations Centre at the hub of the national emergency management system. It's an advanced centre for monitoring and coordinating the federal response to an emergency. 	<ul style="list-style-type: none"> ☐ In the event of a large-scale natural disaster where response and recovery costs exceed what individual provinces and territories could reasonably be expected to bear on their own, PS provides financial assistance to the provincial and territorial governments through the Disaster Financial Assistance Arrangements (DFAA). Assistance is paid to the province or territory – not directly to individuals or communities. The provincial or territorial governments design, develop and deliver disaster financial assistance, determining the amounts and types of assistance that will be provided to those who have experienced losses.

*Canada Energy Regulator Roles & Responsibilities

The CER's top priority in any emergency is to make sure that people are safe and secure, and that property and the environment are protected. Any time there is a serious incident, CER inspectors may attend the site to oversee a company's immediate response. The CER will require that all reasonable actions are taken to protect employees, the public and the environment. Further, the CER will verify that the regulated company conducts adequate and appropriate clean-up and remediation of any environmental effects caused by the incident.

As lead regulatory agency, the CER:

- ☐ Monitors, observes and assesses the overall effectiveness of the company's emergency response in terms of:
 - Emergency Management
 - Safety
 - Security
 - Environment
 - Integrity of operations and facilities; and
 - Energy Supply.
- ☐ Investigates the event, either in cooperation with the Transportation Safety Board of Canada, under the Canada Labour Code, or as per the *Canada Energy Regulator Act* or *Canada Oil & Gas Operations Act* (whichever is applicable)
- ☐ Inspects the pipeline or facility
- ☐ Examines the integrity of the pipeline or facility
- ☐ Requires appropriate repair methods are being used
- ☐ Appropriate environmental remediation of contaminated areas is conducted
- ☐ Coordinate stakeholder and Aboriginal community feedback regarding environmental clean-up and remediation
- ☐ Confirms that a company is following its Emergency Procedures Manual (s), commitments, plans, procedures, and CER regulations and identifies non-compliances
- ☐ Initiates enforcement actions as required
- ☐ Approves the restart of the pipeline.

If applicable; refer to the CER site section behind the blue Area Specific Information tab for further regulations, definitions and, reporting guidelines for CER related incidents specific to this ERP.

*Transportation Safety Board Mandate

The Canadian Transportation Accident Investigation and Safety Board Act provides the legal framework that governs TSB activities. Our mandate is to advance transportation safety in the marine, pipeline, rail and air modes of transportation by:

- ☐ conducting independent investigations, including public inquiries when necessary, into selected transportation occurrences in order to make findings as to their causes and contributing factors;
- ☐ identifying safety deficiencies, as evidenced by transportation occurrences;
- ☐ making recommendations designed to eliminate or reduce any such safety deficiencies; and
- ☐ reporting publicly on our investigations and on the findings in relation thereto.

As part of its ongoing investigations, the TSB also reviews developments in transportation safety, and identifies safety risks that they believe the government and the transportation industry should address to reduce injury and loss.

To instill confidence in the public regarding the transportation accident investigation process, it is essential that an investigating agency be independent and free from any conflicts of interest when investigating accidents, identifying safety deficiencies, and making safety recommendations. As such, the TSB is an independent agency, separate from other government agencies and departments, that reports to Parliament through the President of the Queen's Privy Council for Canada. Our independence enables us to be fully objective in making findings as to causes and contributing factors, and in making transportation safety recommendations.

In identifying the causes and contributing factors of a transportation incident, it is not the function of the Board to assign fault or determine civil or criminal liability. However, the Board does not refrain from fully reporting on the causes and contributing factors merely because fault or liability might be inferred from the Board's findings. No finding of the Board should be construed as assigning fault or determining civil or criminal liability. Findings of the Board are not binding on the parties to any legal, disciplinary, or other proceedings.

<http://tsb-bst.gc.ca/eng/qui-about/index.html>

*Indigenous Services Canada, Regional Operations and First Nations and Inuit Health Branch

Since the Government of Canada's renewed commitment to a stronger relationship with Indigenous peoples in Canada, measures were initiated to effect a shift in the way the Government delivers services to Indigenous peoples. This included the creation of two new departments, which was announced on December 4, 2017. The two newly created departments, Crown-Indigenous Relations and Northern Affairs Canada (CIRNAC) and Indigenous Services Canada (ISC), are intended to improve the delivery of services while accelerating movement towards self-government and self-determination of Indigenous peoples.

As part of the departmental transition, both the former Regional Operations (RO) part of Indigenous and Northern Affairs Canada (INAC) and all of First Nations and Inuit Health Branch (FNIHB) of Health Canada have been absorbed into the newly created Indigenous Services Canada (ISC). RO and FNIHB work closely and collaborate towards the provision of emergency preparedness and response activities to First Nations communities in Canada.

In regards to First Nations emergency management, the role of RO is to liaise, communicate, cooperate, coordinate and collaborate with First Nations and public, private, and non-government sector partners in support of on reserve emergency management service delivery. ISC-RO supports First Nations in the four pillars of emergency management through service agreements with partners such as provincial emergency management agencies and the Red Cross.

FNIHB carries out the public health preparedness and response activities related to natural and man-made disasters. This includes Communicable Disease Control and Environmental Public Health Services. In addition, FNIHB administers Non-Insured Health Benefits to First Nations clients, which includes extended coverage for medical transportation, pharma-care, medical devices and mental health supports. During an emergency, FNIHB works with First Nations leadership and health service providers to ensure health needs of First Nations communities are met.

Provincial specific FNIHB roles & responsibilities will be found in this section of the ERP, if applicable or as appropriate.

*Indian Oil & Gas Canada

IOGC is an organization committed to managing and regulating oil and gas resources on First Nation reserve lands. It is a special operating agency within Indigenous Services Canada.

IOGC is responsible for oil and gas on First Nation reserve lands across Canada, but only a handful of reserves exist north of the 60th parallel. Therefore, practically all of IOGC's work is south of the 60th parallel, with most of that in the Western Canada Sedimentary Basin.

IOGC's general responsibilities are to:

- ☐ identify and evaluate oil and gas resource potential on Indian reserve lands;
- ☐ encourage companies to explore for, drill and produce these resources through leasing activity;
- ☐ ensure equitable production, fair prices and proper collection of royalties on behalf of First Nations; and
- ☐ secure compliance with and administer the regulatory framework in a fair manner.

IOGC operates pursuant to the *Indian Oil and Gas Act, 2009*, and its associated *Indian Oil and Gas Regulations, 2019*, as well as other relevant legislation and guidelines (see Acts and Regulations) which came into force and became law on August 1, 2019. Oil and gas activity on First Nation reserve lands depends on agreements involving First Nation band councils, oil and gas companies, and Indian Oil and Gas Canada.

Additional information is available at: <http://www.pgic-iogc.gc.ca/eng/1100110010458/1100110010464>
Acts and Regulations: <https://www.pgic-iogc.gc.ca/eng/1100110010437/1100110010438>

*CER - Canada Energy Regulator

*TSB - Transportation Safety Board

*PSC - Public Safety Canada

*ISC – Indigenous Services Canada

*FNIHB - First Nation & Inuit Health Branch

*RO - Regional Operations

*IOGC - Indian Oil & Gas Canada

Revised June 2022



National Response System Flowchart

1. When a release or spill of oil or a regulated hazardous material occurs, the organization responsible for the release or spill is required by law to notify the [National Response Center](#) (NRC).
2. Once a report is made, the NRC immediately notifies a designated [On-Scene Coordinator](#) (OSC) in the impacted region as well as tribal, local and state emergency personnel.
3. The OSC coordinates with the state, other personnel on site, and the Potentially Responsible Party (responsible for the release or spill) to determine the status of the response.
4. The OSC determines whether, or how much, federal involvement is necessary and deploys the needed resources.

The OSC may request additional support to respond to a release or spill, such as: additional contractors, technical support from EPA's [Environmental Response Team](#), or Scientific Support Coordinators from EPA or the [National Oceanic and Atmospheric Administration](#). The OSC may also coordinate with the [Regional Response Team \(RRT\)](#) to access special expertise or to provide additional logistical support. In addition, the [National Response Team](#) stands ready to provide policy and logistical support to the OSC and the RRT during an incident.

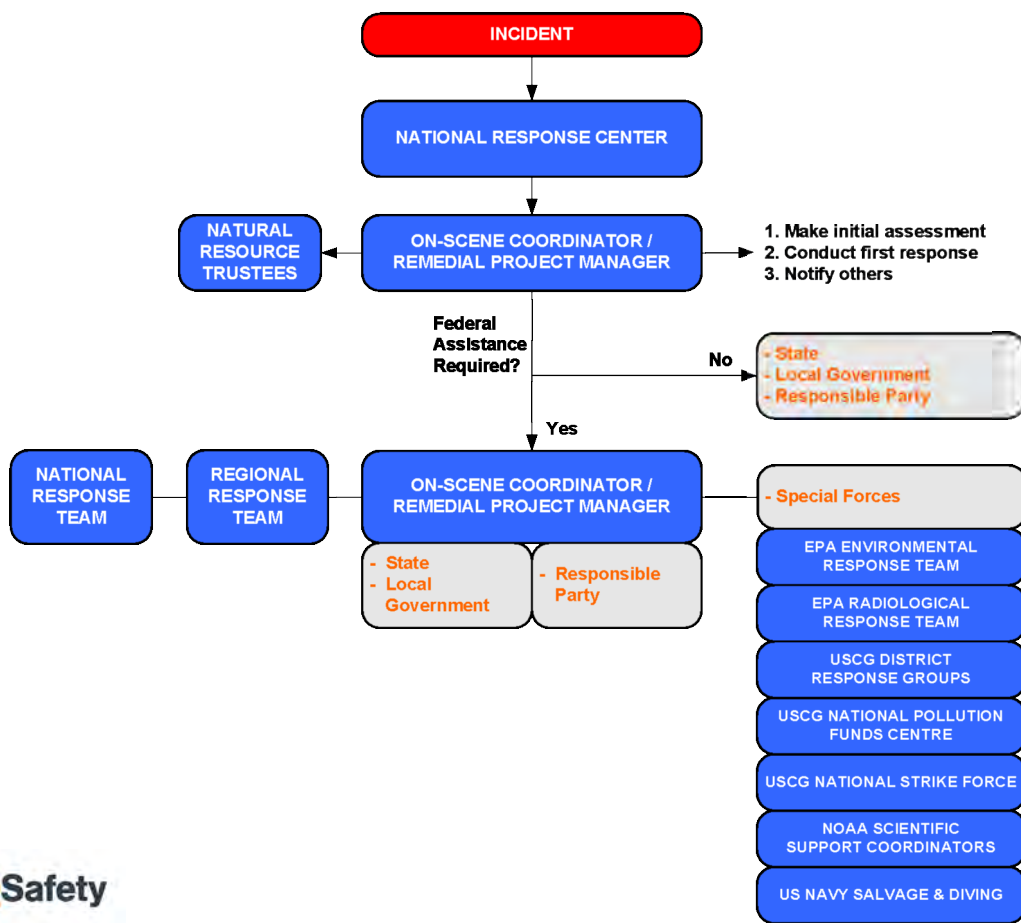

On-Scene Coordinator: The federal officials responsible for monitoring or directing responses to all oil spills and hazardous substance releases. An [OSC](#) is an agent of either EPA (inland areas and waters) or the U.S. Coast Guard (coastal waters and the Great Lakes), depending on where the incident occurs. The [OSC](#) assesses the ability of the responsible party or local authorities to handle the incident, determines the need for personnel, equipment, and other resources, monitors the incident, determines whether federal assistance will be necessary and if so obtains the necessary resources, and evaluates response actions.

National Response Team: Response planning and coordination is accomplished at the federal level through the [U.S. National Response Team \(NRT\)](#), an interagency group co-chaired by the EPA and the U.S. Coast Guard. Although the NRT does not respond directly to incidents, it is responsible for distributing information, planning for emergencies, training for emergencies and supporting the [Regional Response Teams \(RRTs\)](#).

Regional Response Team: There are 13 Regional Response Teams (RRTs), each representing a particular geographic region. RRTs are composed of representatives from field offices of the federal agencies that make up the [National Response Team \(NRT\)](#), as well as state representatives. The RRTs identify available resources from each federal agency and state within their regions and coordinates with federal and state authorities to ensure sufficient equipment & resources are available. RRT members do not respond directly to releases or spills, but may be called upon to provide technical advice, equipment, or manpower to assist with a response. Each RRT develops and trains to a Regional Contingency Plan.

US Federal Agency Roles



US Federal Agency Roles



Federal Agency Roles During a Spill or Release

EPA personnel chair the [NRT](#) and co-chair all [Regional Response Teams \(RRTs\)](#). EPA provides [On-Scene Coordinators \(OSCs\)](#), scientific support coordinators for inland spills, and Remedial Project Managers for hazardous waste remedial actions under Superfund. EPA funds the [Environmental Response Team \(ERT\)](#), which is dispatched at the OSC's request to any response episode exceeding available regional resources. The ERT can provide support for site assessments, health and safety issues, action plan development, and contamination monitoring. EPA also provided legal expertise to interpret environmental statutes.

EPA

The [EPA's Environmental Response Team's \(ERT\)](#) supports the nation's response, cleanup, and renewal of its contaminated land, water, and air by maintaining around-the-clock readiness to provide expertise at the scene of a hazardous substance release or a long-term environmental cleanup. ERT can provide support for the full range of emergency response actions, including unusual or complex emergency incidents such as an underwater release. In such cases, the team can bring in special equipment with technically adept responders providing the on-site coordinator or remedial project manager with experience and advice.

EPA ERT

The [EPA's Radiological Emergency Response Team \(RERT\)](#) works with federal, state and local agencies to monitor radioactivity and clean up affected areas. During an emergency, EPA uses its protective action guidelines to help determine what actions are necessary to protect people from unhealthy levels of radiation.

EPA RERT

An agency of the U.S. Department of Homeland Security, the [U.S. Coast Guard](#) serves as Vice Chair for the NRT. U.S. Coast Guard provides OSCs for coastal zones and co-chairs all RRTs. 24 hour-a-day staffed facilities in 46 "Captain of the Port Zones" are maintained by the U.S. Coast Guard, for command, control, and surveillance of releases in coastal waters. The U.S. Coast Guard manages the National Response Center and maintains a [National Strike Force](#), which is specially trained and equipped to respond to major marine pollution incidents. The U.S. Coast Guard's Strike Teams are based on the Pacific and Gulf Coasts. The U.S. Commandant of the Coast Guard also serves as fund manager for the Oil Spill Liability Trust Fund (OSLTF) set up under the Clean Water Act. The [National Pollution Funds Center \(NPFC\)](#) manages funds for the Oil Spill Liability Trust Fund (OSLTF) and is an independent unit of the U.S. Coast Guard. In addition, the U.S. Coast Guard District Response Group (DRG) provides a framework for the Coast Guard districts to organize their response operations. The DRG consists of all Coast Guard units, personnel and equipment within a district's boundary, all pre-positioned response equipment strategically located in the district, and the District Response

US Coast Guard

During a response effort, [FEMA](#) advises and aids lead agencies in coordinating relocation assistance. The agency provides guidance, policy, and technical assistance in emergency preparedness planning, training, and exercising activities for state and local governments.

FEMA

[DOD](#) acts when oil or hazardous substances are released from a facility or vessel under its jurisdiction. Upon request, DOD will provide U.S. Navy oil spill containment and recovery equipment and manpower, as well as equipment for ship salvaging, shipboard damage control, and diving. DoD can also make U.S. Army Corp of Engineer equipment and expertise available for removing navigational obstructions and performing ship structural repairs.

DOD

The [U.S. Navy Superintendent of Salvage and Diving](#) has extensive equipment and expertise for supporting responses to open-sea pollution incidents. Specialized capabilities include salvage, firefighting, and petroleum, oil and lubricants offloading.

US Navy

[DOE](#) provides OSCs when hazardous substances are released from DOE facilities, or when materials being transported under DOE's control are spilled. DOE staff aids in the control of immediate radiological hazards.

DOE

Federal Agency Roles During a Spill or Release

USDA	<p>USDA measures, evaluates, and monitors situations where natural resources, including soil, water, wildlife, and vegetation have been affected by hazardous substances. USDA contributes expertise from the following organizations: Forest Service, Agriculture Research Service, Natural Resources Conservation Service (formerly Soil Conservation Service), Food Safety and Inspection Service & Animal and Plant Health Inspection Service.</p>
DEPT OF COMMERCE	<p>This department, through the National Oceanic and Atmospheric Administration (NOAA), provides scientific support for resources and contingency planning in coastal and marine areas including hazard assessment and spill trajectory (direction) monitoring to predict movement and dispersion of oil and other hazardous substances. NOAA contributes information about sensitive coastal environments, and furnishes data about actual and predicted meteorological, hydrological, ice, and oceanographic conditions. NOAA also serves as the natural resource trustee for the living marine resources it manages and protects. NOAA's Office of Response and Restoration works to remediate damage to coastline and marine resources caused by oil and hazardous substance releases. Their scientists analyze and identify solutions to environmental contamination.</p>
HHS	<p>Health hazards at a response are assessed by HHS. Agencies within HHS that maintain and provide information on health effects include the Agency for Toxic Substances and Disease Registry and the National Institutes for Environmental Health Sciences (NIEHS). NIEHS also offers training on the health effects of oil spills. HHS also provides technical guidance regarding worker health and safety through the National Institute for Occupational Safety and Health.</p>
DOI	<p>DOI contributes expertise on natural resources, endangered species, and federal lands and waters, and is responsible for native Americans and U.S. territories. Regional Environmental Officers of DOI are designated members of RRTs DOI serves as a natural resource trustee for the resources it manages or protects. Bureaus within the department with expertise include: Fish and Wildlife Service, Geological Survey Bureau of Indian Affairs, Bureau of Land Management, Minerals Management Service, Bureau of Mines, National Park Service, Bureau of Reclamation, Office of Surface Mining and Reclamation Enforcement & Office of Territorial Affairs.</p>
DOJ	<p>DOJ provides expert advice on legal questions arising from discharges or releases, and federal agency responses, can be obtained from this agency. DOJ represents the federal government in litigation relating to discharges or releases.</p>
DOL	<p>Through the Occupational Safety and Health Administration, DOL conducts safety and health inspections of hazardous waste sites to ensure that onsite employees are protected from hazards and to determine if a site is in compliance with safety and health standards and regulations.</p>
DOT	<p>Response expertise is provided by DOT pertaining to transportation of oil or hazardous substances through the Pipeline and Hazardous Materials Safety Administration (PHMSA). PHMSA offers specialized advice on requirements of packaging, handling, and transporting regulated hazardous materials. PHMSA serves other functions, including promulgating and enforcing hazardous materials regulations (49 CFR Part 100.199), producing emergency response guidebooks, and supporting protective action decision strategies and exercise scenarios.</p>
NRC	<p>When radioactive materials by its licensees are released, the NRC responds in accordance with its incident response plan.</p>
DEPT OF STATE	<p>The Department of State takes the lead in developing international contingency plans. It helps coordinate international response efforts, when discharges or releases cross international boundaries or involve foreign flag vessels. The agency also coordinates requests for aid from foreign governments.</p>

USDA - Department of Agriculture

HHS - Department of Health & Human Services

DOI - Department of Interior

DOJ - Department of Justice

DOL - Department of Labour

DOT - Department of Transportation

NRC - Nuclear Regulatory Commission

US Federal Agency Roles





Section 6: Forms

Documentation During and After an Incident

Form Descriptions

Incident Command System (ICS) Forms

- ICS 201 Incident Briefing
- ICS 202 Incident Objectives
- ICS 203 Organization Assignment List
- ICS 204 Assignment List
- ICS 207 Incident Organization Chart
- ICS 208 Safety Message / Plan
- ICS 209 Incident Status Summary
- ICS 211 Check-In / Out List
- ICS 214 Activity Log
- ICS 215 Operational Planning Worksheet
- ICS 215A IAP Safety Analysis
- ICS 221 Demobilization Checkout
- ICS 230 Meeting Schedule
- ICS 231 Meeting Summary
- ICS 233 Incident Open Action Tracker

Emergency Forms

- A1 Initial Emergency Report Form
- A2 Odour Complaint Script
- A3 Regulatory First Call Communication
- A4 Incident Action Plan Checklist
- A5 Air Monitoring Log
- A6 Threatening Call / Bomb Threat
- A7 STARS Landing Zone Card

Resident Forms

- B1 Reception Centre Registration Log
- B2 Resident Compensation Log
- B3 Resident Contact Log
- B4 Roadblock Log
- B5 Evacuation Notice
- B6 Early Notification / Voluntary Evacuation Phone Message
- B7 Shelter-In-Place Phone Message
- B8 Evacuation Phone Message

Media Forms

- C1 Preliminary Media Statement
- C2 Media Contact Log
- C3 Government Agency Contact Log
- C4 Media Centre Site



Documentation During and After an Incident

All personnel are required to document their actions on the ICS 214 – Activity Log throughout the duration of the incident. Additionally, note takers should be assigned to take notes at meetings and to document the discussions, decisions, overall activities, etc. at the Incident Command Post (ICP) and Emergency Operations Centre (EOC). The status of any changing documents such as status boards, wall charts, laminated maps with mark-ups, etc. should be captured prior to each set of new changes. It is essential that all documentation is correctly dated, and time stamped to provide the correct order and time of events.

It is imperative that accurate documentation is kept throughout the duration of an incident for record keeping purposes. Records kept may be used for legal, investigation, audits, historical and/or analytical purposes. All documentation must be held for a minimum of 5 years as it may be requested by the regulatory agency at any point during that time.

It is the Documentation Units responsibility to collect documentation (forms, checklists, event logs, etc.) from response team members and maintain a consistent system for organizing the data.

Form Descriptions

The Incident Command System uses a series of standard forms and supporting documents that convey directions for the accomplishment of the objectives and distributing information. Listed below are the standard ICS form titles and descriptions of each form utilized.

Further ICS forms can be found through the ICS Canada website: <http://www.icscanada.ca/en/forms.html>.

Standard ICS Form Title	ICS Form Description
ICS 201 Incident Briefing	Provides the Incident Command and General Staffs with basic information regarding the incident situation and the resources allocated to the incident. This form also serves as a permanent record of the initial response to the incident.
ICS 202 Incident Objectives	Describes the basic strategy and objectives for use during each operational period.
ICS 203 Organization Assignment List	Provides ICS personnel with information on the units that are currently activated and the names of personnel staffing each position.
ICS 204 Assignment List	Informs Division and Group supervisors of incident assignments.
ICS 207 Incident Organization Chart	A complete picture of the organizational structure for the incident.
ICS 208 Safety Message / Plan	Expands on the Safety Message and Site Safety Plan.
ICS 209 Incident Status Summary	Summarizes incident information for staff members and external parties, and provides information to the Public Information Officer for preparation of media releases.
ICS 211 Check-In/Out List	Used to check in personnel and equipment arriving at or departing from the incident. Check-in / out consists of reporting specific information that is recorded on the form.
ICS 214 Activity Log	Provides a record of unit activities. Unit Logs can provide a basic reference from which to extract information for inclusion in any after-action report.



Form Descriptions, continued

Standard ICS Form Title	ICS Form Description
ICS 215 Operational Planning Worksheet	Documents decisions made concerning resource needs for the next operational period. The Planning Section uses this Worksheet to complete Assignment Lists, and the Logistics Section uses it for ordering resources for the incident. This form may be used as a source document for updating resource confirmation on other ICS forms such as the 209 Incident Status Summary.
ICS 215A Incident Action Plan Safety Analysis	Used to communicate to the Operations and Planning Section Chiefs the potential hazards identified by the Safety Officer. It identifies mitigation measures to address the identified hazards.
ICS 221 Demobilization Checkout	Ensures that resources checking out of the incident have completed all appropriate incident business, and provides the Planning Section information on resources released from the incident.
ICS 230 Meeting Schedule	To record information about the daily scheduled meeting activities.
ICS 231 Meeting Summary	Provides more detailed information concerning the attendees and notes from a particular meeting.
ICS 233 Incident Open Action Tracker	Used by Command Staff to track time sensitive tasks / actions assigned to incident personnel.

Emergency Form Title	Emergency Form Description
A1 Initial Emergency Report Form	Used by recipient of a phone call from either a member of the public or other company personnel to record detailed information about incident.
A2 Odour Complaint Script	Used to record odour information from a member of the public as well as scripts to follow.
A3 Regulatory First Call Communication	A regulatory required form used to send detailed information to the regulator about an emergency used for assessment, historical, and analytical purposes following an incident.
A4 Incident Action Plan Checklist	A checklist of other forms and information required to accurately create an incident action plan.
A5 Air Monitoring Log	A form used by designated Air Monitor personnel to log information about air quality readings.
A6 Threatening Call / Bomb Threat	Detailed point driven form used to document incoming phone calls pertaining to personnel threats and bomb threats.
A7 Stars Landing Zone Card	An information card utilized if medical evacuation is required via STARS Air Ambulance.

Resident Form Title	Resident Form Description
B1 Reception Centre Registration Log	Log used by Reception Centre Rep to record information from evacuees being received at the reception centre. Can also be faxed to reception centre in case a representative has not been identified or cannot make it before evacuees start arriving.
B2 Resident Compensation Log	Detailed spreadsheet for expenses incurred by evacuees so that compensation may be properly dealt with.



Form Descriptions, continued

Resident Form Title	Resident Form Description
B3 Resident Contact Log	A log used by various company personnel to record contact made with residents, whether they're sheltered / evacuated and if assistance is required.
B4 Roadblock Log	A log used by designated Roadblock personnel to identify details about vehicles and persons entering or exiting a hazard area.
B5 Evacuation Notice	A document to be left in doors / windows of surface developments that are unable to be contacted as a way to issue evacuation instructions
B6 Early Notification/Voluntary Evacuation Message	A script and document filled out by Telephoner personnel issuing calls to residents for early notification and voluntary evacuation purposes.
B7 Shelter-In-Place Message	A script and document filled out by Telephoner personnel issuing calls to residents with shelter-in-place instructions.
B8 Evacuation Phone Message	A script and document filled out by Telephoner personnel issuing calls to residents with evacuation instructions.

Media Form Title	Media Form Description
C1 Preliminary Media Statement	A generic script used by the Media Spokesperson to issue media statements until which time more detailed information is known and can be issued.
C2 Media Contact Log	A log used to identify what media outlets/persons have contacted the company and their contact information.
C3 Government Agency Contact Log	A log used to identify what government agencies have been notified about the incident.
C4 Media Centre Site	A document to distribute to media outlets/persons about the location for further media enquiries and press releases as well as details to get there.

ICS 201 Incident Briefing Form



Incident Name:				
Date/Time Initiated:				
Prepared By:			ICS Position:	
Level of Emergency	Alert / Minor	Level 1	Level 2	Level 3
Map Sketch:				
<i>Note: Maps can be drawn or attached here.</i>				
Situation Summary: (Write description or attach A1)				
Safety Briefing:				

ICS 201 Incident Briefing Form



Current and Planned Objectives:	
Priorities: (1) Life Safety (2) Incident Stabilization (3) Environment & Property	
1. Ensure Safety of Citizens and Response Personnel:	4. Minimize Economic Impacts:
<input type="checkbox"/> 1a. Identify hazard(s) of released product.	<input type="checkbox"/> 4a. Consider tourism and local economic impacts.
<input type="checkbox"/> 1b. Establish site control (hot zone, warm zone, cold zone, & security).	<input type="checkbox"/> 4b. Protect public and private assets, as resources permit.
<input type="checkbox"/> 1c. Establish an Emergency Response Zone and Initiate Public Safety Actions.	<input type="checkbox"/> 4c. Establish damage claims process.
<input type="checkbox"/> 1d. Consider evacuations if needed.	5. Keep Stakeholders and Public Informed of Response Activities:
<input type="checkbox"/> 1e. Establish aircraft restrictions.	<input type="checkbox"/> 5a. Provide forum to obtain stakeholder input and concerns.
<input type="checkbox"/> 1f. Monitor air in impacted areas	<input type="checkbox"/> 5b. Provide stakeholders with details of response actions.
<input type="checkbox"/> 1g. Develop site safety plan for personnel and ensure safety briefings are conducted.	<input type="checkbox"/> 5c. Identify stakeholder concerns and issues, and address as practical.
2. Control the Source of the Release:	<input type="checkbox"/> 5d. Provide timely safety announcements.
<input type="checkbox"/> 2a. Complete emergency shutdown.	<input type="checkbox"/> 5e. Conduct regular news briefings.
<input type="checkbox"/> 2b. Conduct firefighting.	<input type="checkbox"/> 5f. Conduct public meetings, as appropriate.
<input type="checkbox"/> 2c. Initiate temporary repairs.	
3. Manage a Coordinated Response Effort:	
<input type="checkbox"/> 3a. Complete or confirm notifications.	
<input type="checkbox"/> 3b. Establish a unified command organization and facilities (command post, etc.).	
<input type="checkbox"/> 3c. Ensure mobilization and tracking of resources and account for personnel and equipment.	
<input type="checkbox"/> 3d. Complete documentation.	
Current and Planned Actions, Strategies and Tactics:	
Time:	Actions:
HHMM	
HHMM	
HHMM	
HHMM	
HHMM	
HHMM	
HHMM	
HHMM	
HHMM	

ICS 201 Incident Briefing Form



Current Organizational Structure: (draw in current response structure)*

*** This is a condensed Organizational Chart to account for all currently responding personnel during the Initial Response.**

Incident Commander

Name _____

Number _____

Information Officer

Name _____

Number _____

Liaison Officer

Name _____

Number _____

Safety Officer

Name _____

Number _____

On-Site Group Supervisor

Name _____

Number _____

Site Safety

Name _____

Number _____

Control

Name _____

Number _____

Containment

Name _____

Number _____

Other

Name _____

Number _____

Other

Name _____

Number _____

Other

Name _____

Number _____

Public Safety Group Supervisor

Name _____

Number _____

Air Monitors

Name _____

Number _____

Roadblocks

Name _____

Number _____

Rovers

Name _____

Number _____

Telephoners

Name _____

Number _____

Reception Centre Representative

Name _____

Number _____

Other

Name _____

Number _____

Documentation

Name _____

Number _____

Note: Refer to ICS 207 Incident Organization Chart in Section 6: Forms (Blue Tab) for full command structure.

Section 6: Forms

Page 3 of 6

ICS 201 Incident Briefing Form



Site Safety and Hazard Control Analysis	
Site Control	
1. Is Site Control set-up? <input type="checkbox"/> Yes <input type="checkbox"/> No	2. Is there an On-Scene Command Post? <input type="checkbox"/> Yes <input type="checkbox"/> No If so, where?
3. Have all personnel been accounted for? <input type="checkbox"/> Yes <input type="checkbox"/> No <input type="checkbox"/> Don't Know	Injuries: _____ Unaccounted: _____ Fatalities: _____ Trapped: _____
4. Are observers involved or rescue attempts planned? Observers: <input type="checkbox"/> Yes <input type="checkbox"/> No Rescuers: <input type="checkbox"/> Yes <input type="checkbox"/> No	5. Are Decontamination areas setup? <input type="checkbox"/> Yes <input type="checkbox"/> No If so, where?
Hazard Identification, immediate signs of: (if yes, explain in remarks)	
1. Electrical line(s) down or overhead? <input type="checkbox"/> Yes <input type="checkbox"/> No	2. Unidentified liquid or solid products visible? <input type="checkbox"/> Yes <input type="checkbox"/> No
3. Wind direction across incident: <input type="checkbox"/> Towards your position Wind Speed: <input type="checkbox"/> Away from your position	4. Is a safe approach possible? <input type="checkbox"/> Yes <input type="checkbox"/> No
5. Odours or smells? <input type="checkbox"/> Yes <input type="checkbox"/> No	6. Vapours visible? <input type="checkbox"/> Yes <input type="checkbox"/> No
7. Holes, ditches, fast water, cliffs, etc. nearby? <input type="checkbox"/> Yes <input type="checkbox"/> No	8. Fire, sparks, sources of ignition nearby? <input type="checkbox"/> Yes <input type="checkbox"/> No
9. Is local traffic a potential problem? <input type="checkbox"/> Yes <input type="checkbox"/> No	10. Product placards, colour codes visible? <input type="checkbox"/> Yes <input type="checkbox"/> No
11. Other Hazards? <input type="checkbox"/> Yes <input type="checkbox"/> No	12. As you approach the scene from the upwind side, do you note a change in the status of any of the above? <input type="checkbox"/> Yes <input type="checkbox"/> No
13. Remarks:	
Hazard Mitigation: have you determined the necessity for any of the following?	
1. Entry Objectives:	
2. Warning sign(s), barriers, colour codes in place? <input type="checkbox"/> Yes <input type="checkbox"/> No	
3. Hazardous material being monitored? <input type="checkbox"/> Yes <input type="checkbox"/> No 3a. Sampling equipment: 3b. Sampling location(s): 3c. Sampling frequency: 3d. Peak reading: 3e. Personal exposure monitoring:	
4. Protective gear / level: 4b. Respirators 4d. Boots:	4a. Gloves: 4c. Clothing: 4e. Chemical cartridge change frequency:
5. Decontamination 5a. Instructions: 5b. Decontamination equipment and materials:	
6. Emergency escape route established? <input type="checkbox"/> Yes <input type="checkbox"/> No Route?	
7. Field responders briefed on hazards? <input type="checkbox"/> Yes <input type="checkbox"/> No	
8. Remarks:	
Protective Zones: record initial control perimeters (see Figure 1)	

ICS 202 Incident Objectives



Incident Name:	
Date / Time Initiated:	
Prepared by:	ICS Position:
General Control Objectives for the Incident:	
1	
2	
3	
4	
5	
Weather Forecast:	
General Safety Message:	
<i>Note: Create and prioritize SMART (Specific, Measureable, Attainable, Realistic, & Time-Sensitive) objectives that address the incident issues and utilize the solutions identified on the Operations Briefing page.</i>	



ICS 203 Organization Assignment List



Incident Name			Operational Period (Date/Time) From: _____ To: _____	
Incident Commander(s)			Operations Section	
Agency	IC	Deputy	Chief	
			Deputy	
			Staging Area Manager	
			On-Site Group	
			Supervisor	
Safety Officer			Lead	
Assistant			Lead	
Information Officer			Lead	
Assistant			Lead	
Liaison Officer			Lead	
Assistant				
			Public Safety Group	
			Supervisor	
Agency Representatives			Lead	
Agency	Name		Lead	
			Lead	
			Lead	
			Lead	
			Lead	
			Branch – Division / Group	
			Branch Director	
			Deputy	
Planning Section			Division/Group	Lead
Chief			Division/Group	Lead
Deputy			Division/Group	Lead
Resources Unit			Division/Group	Lead
Situation Unit			Division/Group	Lead
Environmental Unit				
Documentation Unit			Branch – Division / Group	
Demobilization Unit			Branch Director	
Technical Specialists			Deputy	
			Division/Group	Lead
			Division/Group	Lead
Logistics Section			Division/Group	Lead
Chief			Division/Group	Lead
Deputy			Division/Group	Lead
Supply Unit				
Facilities Unit			Finance / Admin Section	
Ground Support Unit			Chief	
Communications Unit			Deputy	
Medical Unit			Time Unit	
Food Unit			Procurement Unit	
			Compensation / Claims Unit	
			Cost Unit	
Prepared By: (Resources Unit)			Date/Time	





ICS 207 Incident Organization Chart

Incident Name: _____

Date: _____ Time: _____

Operational Period: _____

- KEY INFORMATION:**
- The Incident Commander is responsible for all Field Response positions until the position is delegated.
 - This organizational chart is a starting point, the structure expands and contracts based on the incident needs.
 - Information can flow anywhere throughout the organizational structure, decisions **must** flow up the chain of command.
 - Company Phone List can be found behind the Response Teams Phone List tab

Indicates a position that is always filled regardless of the size of the incident. 

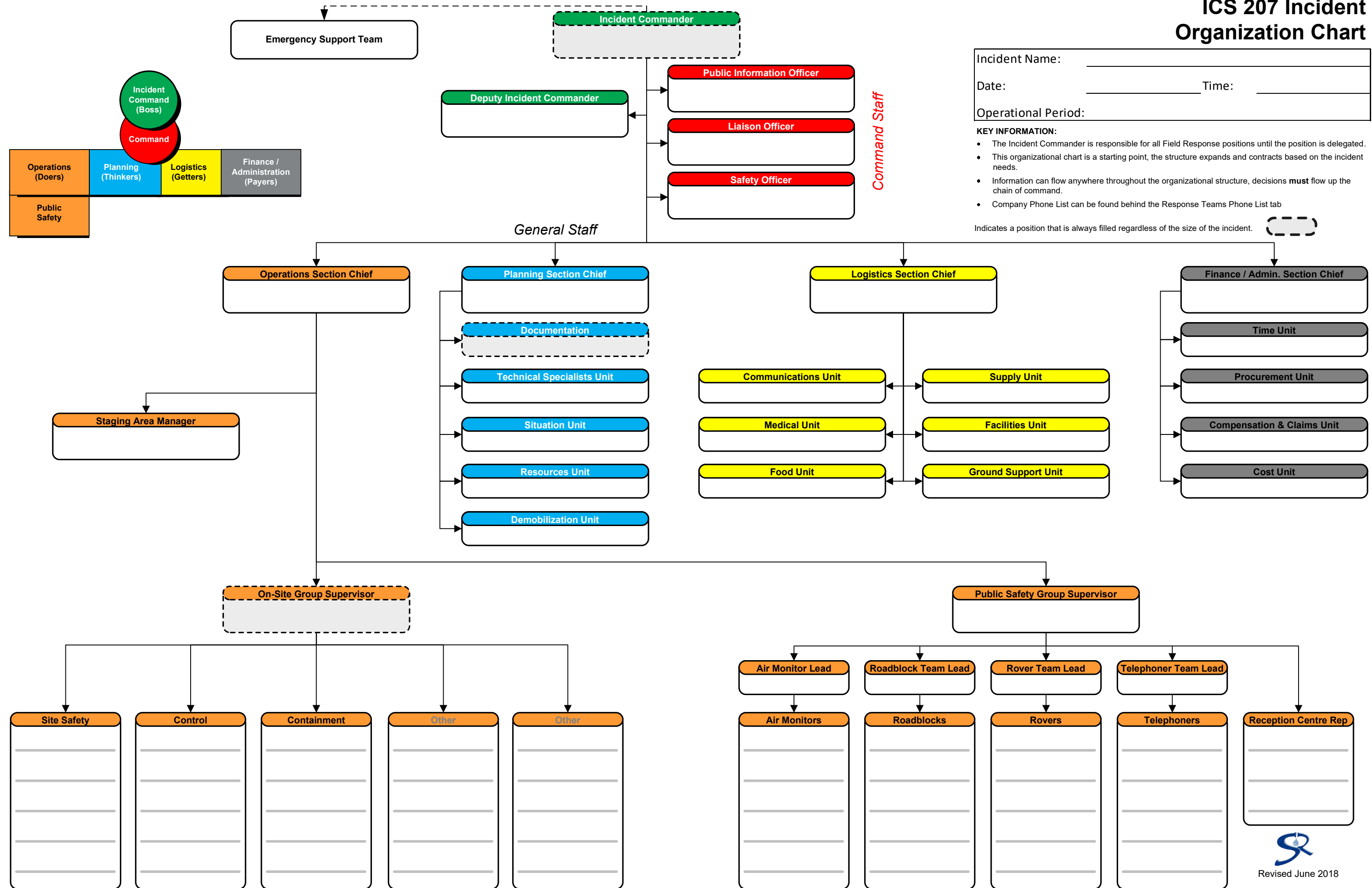

Incident Command (Boss)

Command

Operations (Doers) | Planning (Thinkers) | Logistics (Getters) | Finance / Administration (Payers)

Public Safety

ICS 208 Safety Message / Plan



Incident Name:	Operational Period: From: Date _____ Time _____ To: Date _____ Time _____	
Safety Message/Expanded Safety Message, Safety Plan, Site Safety Plan:		
Site Safety Plan Required? <input type="checkbox"/> Yes <input type="checkbox"/> No Approved Site Safety Plan(s) Located At:		
Prepared By: (Name and Position)	Date Prepared:	
Signature:	Time Prepared:	



ICS 209 Incident Status Summary



Incident Name:		Location of Incident:	
Date / Time Initiated:		(LSD / NTS)	
Prepared by:		ICS Position	
Incident Details:			
Gas readings:	H ₂ S	SO ₂	LEL
Level of Emergency:			
Incident Severity:		<input type="checkbox"/> Alert / Minor	<input type="checkbox"/> Level 1 <input type="checkbox"/> Level 2 <input type="checkbox"/> Level 3
Affect Medium: (Check all that apply)			
<input type="checkbox"/> Air	<input type="checkbox"/> Water	<input type="checkbox"/> Soil	<input type="checkbox"/> Other – Specify:
Site Type: (Select only 1)			
<input type="checkbox"/> Well (Active)		<input type="checkbox"/> Well (Abandoned/Suspended)	<input type="checkbox"/> Remote Sump
<input type="checkbox"/> Well (Drilling & Completions): Rig Name:			
<input type="checkbox"/> Battery/Plant/Facility		<input type="checkbox"/> Tank Farm/Storage	<input type="checkbox"/> Pipeline
<input type="checkbox"/> Riser (Pipeline)			
<input type="checkbox"/> Road or Road Structure		Name:	Location on Road:
<input type="checkbox"/> Other – Specify:			
Incident Type: (Check all that apply)			
<input type="checkbox"/> Sour Gas Release		<input type="checkbox"/> Sweet Gas Release	<input type="checkbox"/> Liquid Spills
<input type="checkbox"/> Natural Disaster/Weather		<input type="checkbox"/> Fire/Explosion	<input type="checkbox"/> Drilling Kick
<input type="checkbox"/> Worker Injury/Fatality		<input type="checkbox"/> Security (theft, threat, terrorism)	<input type="checkbox"/> Induced Seismicity
<input type="checkbox"/> Well Bore Communication		<input type="checkbox"/> Pipeline Boring	<input type="checkbox"/> Vehicle/Transportation
<input type="checkbox"/> Equipment/Structural Damage		<input type="checkbox"/> Pipeline Break	<input type="checkbox"/> Well Control
<input type="checkbox"/> Other – Specify:			
Activity: (Check all that apply)			
<input type="checkbox"/> Construction (Road, Lease, Pipe)		<input type="checkbox"/> Drilling/Exploration	<input type="checkbox"/> Waste Management
<input type="checkbox"/> Processing		<input type="checkbox"/> Well Fracturing	<input type="checkbox"/> Servicing
<input type="checkbox"/> Repair		<input type="checkbox"/> Flaring (Emergency)	<input type="checkbox"/> Well Testing
<input type="checkbox"/> Pressure Testing		<input type="checkbox"/> Transportation	
<input type="checkbox"/> Other – Specify:			

ICS 209 Incident Status Summary



Consequence or Impacts: (Check all that apply, if none, leave blank)			
<input type="checkbox"/> Worker Safety (Injuries, Fatalities)		<input type="checkbox"/> Property	
<input type="checkbox"/> Economic (Loss of and/or damage to equipment or infrastructure, loss of production, work stoppage)			
<input type="checkbox"/> Other – Specify:			
Material Information:			
Is spill off lease?		<input type="checkbox"/> Yes - Estimated spill quantity: <input type="checkbox"/> No	
<input type="checkbox"/> Liquid Hydrogen (Crude, Oil, Diesel, Fuel)		<input type="checkbox"/> Toxic Gas Liquid (>1% Different Toxins)	
<input type="checkbox"/> Acid	<input type="checkbox"/> Emulsion (Oil, Gas, Water)	<input type="checkbox"/> Sweet Natural Gas	<input type="checkbox"/> Salt Water
<input type="checkbox"/> Methanol	<input type="checkbox"/> Non-Toxic Liquids		<input type="checkbox"/> Fresh Water
<input type="checkbox"/> Sour Natural Gas	<input type="checkbox"/> Sour Liquids (<1% H ₂ S)	<input type="checkbox"/> Other – Specify:	
<input type="checkbox"/> Non-Toxic Gases (Nitrogen, Carbon Dioxide, Inert Gases)			
Area Information:			
Land Type:		Field Name:	
<input type="checkbox"/> Private Land <input type="checkbox"/> Crown Land			
Area Type: <input type="checkbox"/> Forest <input type="checkbox"/> Muskeg <input type="checkbox"/> Farmland <input type="checkbox"/> Residential <input type="checkbox"/> Other			
Access: <input type="checkbox"/> Helicopter <input type="checkbox"/> ATV <input type="checkbox"/> 4WD <input type="checkbox"/> 2WD <input type="checkbox"/> Unknown			
Name of road the asset is located on:			
KM where the incident occurred:			
Distance to nearest residence/public facility:			
Nearest City/Town/Open Camp:			
Weather Conditions:			
Weather Conditions <input type="checkbox"/> Clear <input type="checkbox"/> Cloudy <input type="checkbox"/> Other:			
Wind Direction N NE NW E SE S SW W			
Wind Strength <input type="checkbox"/> Calm <input type="checkbox"/> Moderate <input type="checkbox"/> Strong <input type="checkbox"/> Gusty			
Temperature °C			
Public / Worker Injuries / Medical Emergencies:			
<input type="checkbox"/> First Aid	<input type="checkbox"/> Hospitalization	<input type="checkbox"/> Fatality	<input type="checkbox"/> Other – Specify:
Notification: (Notify all agencies as required)			
<input type="checkbox"/> 911 (Police/RCMP, Fire, EMS)	<input type="checkbox"/> Energy Regulator (BCER, AER*, etc.)	<input type="checkbox"/> Local Authority (MD, County, Town, City)	<input type="checkbox"/> Health Authority
<input type="checkbox"/> Canada Energy Regulator (CER)	<input type="checkbox"/> Occupational Health & Safety (OH&S)	<input type="checkbox"/> Emergency Management Agency	<input type="checkbox"/> Ministry of Transportation
<input type="checkbox"/> Workers' Compensation Board (WCB)	<input type="checkbox"/> Emergency Response Assistance Canada (ERAC)	<input type="checkbox"/> Western Canadian Spill Services (WCSS)	<input type="checkbox"/> CANUTEC
<input type="checkbox"/> Transportation Dangerous Goods (TDG)	<input type="checkbox"/> <i>Other</i>	<input type="checkbox"/> <i>Other</i>	<input type="checkbox"/> <i>Other</i>
<input type="checkbox"/> <i>Other</i>	<input type="checkbox"/> <i>Other</i>	<input type="checkbox"/> <i>Other</i>	<input type="checkbox"/> <i>Other</i>
<small>*Request that the AER notify Alberta Environment & Parks (Forestry/Fish/Wildlife/Lands), Environment & Climate Change Canada (ECCC) and the Department of Fisheries and Oceans as required.</small>			
Refer to the Government Notification Matrix and External Agencies Contact List or Area Specific Information for complete list of agencies requiring contact.			

ICS 209 Incident Status Summary



Agency Notification			
Agency Name	Contact Name	Contact Number	Notified (Y/N)

Collect all completed C3 Government Agency Contact Logs from responders for full documentation.

Notes:

Roadblock Locations:		
Roadblock Number	Name	Location/LSD

Collect all completed B4 Roadblock Logs from responders for full documentation.

Notes:

ICS 211 Check-In / Out List



Incident Name:							
Date / Time Initiated:							
Prepared by:				ICS Position:			
Check-in Location		<input type="checkbox"/> Staging Area		<input type="checkbox"/> ICS Res. Unit		<input type="checkbox"/> Other:	
Name of Company	Date of Check-in	Supervisor Name	Total # of Personnel	Incident Assignment	Assigned	Available	Date of Check-out
Notes:							





ICS 215 Operational Planning Worksheet



Incident Name:				Operational Period: To: Date _____ Time _____ To: Date _____ Time _____														
Branch	Division, Group, or Other	Work Assignments & Special Instructions	Resources											Overhead Position(s)	Special Equipment & Supplies	Reporting Location	Requested Arrival Time	
				Req.	Have	Need	Req.	Have	Need	Req.	Have	Need	Req.					Have
			Req.															
			Have															
			Need															
			Req.															
			Have															
			Need															
			Req.															
			Have															
			Need															
			Req.															
			Have															
			Need															
			Req.															
			Have															
			Need															
		Total Resources Required:													Prepared by: Name: Position/Title: Date/Time: Signature:			
		Total Resources - Have on Hand:																
		Total Resources Need to Order:																



ICS 215a Incident Action Plan Safety Analysis



Incident Name:						Date / Time Initiated:					
Prepared by:						ICS Position:					
Division or Group	Potential Hazards									Controls (e.g., PPE, buddy system, escape routes)	
	Type of Hazard	Type of Hazard	Type of Hazard	Type of Hazard	Type of Hazard	Type of Hazard	Type of Hazard	Type of Hazard	Type of Hazard	Type of Hazard	



ICS 221 Demobilization Checkout



Incident Name / Number:		Date / Time:		Demob. Number:	
Unit/Personnel Released:					
Transportation Type / Number:					
Actual Release Date / Time:				Manifest Completed? <input type="checkbox"/> Yes <input type="checkbox"/> No	
Destination:		Notify:	<input type="checkbox"/> HQ	<input type="checkbox"/> Agency	<input type="checkbox"/> Region
		Name:			
		Date:			
Unit Leader responsible for collecting performance rating					
Unit / Personnel					
You and your resources have been released subject to Sign-Off from the following: Demobilization Unit Leader – Check the appropriate box					
Logistics Section					
<input type="checkbox"/> Supply Unit					
<input type="checkbox"/> Communications Unit					
<input type="checkbox"/> Facilities Unit					
<input type="checkbox"/> Ground Support Unit Leader					
Planning Section					
<input type="checkbox"/> Demobilization Unit					
Finance/Admin Section					
<input type="checkbox"/> Time Unit					
Other					
<input type="checkbox"/>					
<input type="checkbox"/>					
Remarks:					
Page		of		Prepared By: (Name and Position)	Signature:



ICS 230 Meeting Schedule



Incident Name:		Operational Period: From: Date _____ Time _____		
Meeting Schedule (Commonly-held meetings are included)				
Date / Time	Meeting Name	Purpose	Attendees	Location
Prepared by: (Situation Unit Leader)			Date / Time:	



ICS 231 Meeting Summary



Incident Name:	Meeting Date / Time:
Meeting Name:	
Meeting Location:	
Meeting Facilitator:	
Attendees:	
Notes: (with summary of decisions and action items)	
Prepared by:	Date / Time:



ICS 233 Incident Open Action Tracker



Incident Name:							
No.	Item	For	Status	Start Date	Briefed	Target Date	Actual Date
1							
2							
3							
4							
5							
6							
7							
8							
9							
10							
11							
12							
13							
14							
15							
16							
17							
18							
19							
20							

ICS 233 Incident Open Action Tracker



No.	Item	For	Status	Start Date	Briefed	Target Date	Actual Date
21							
22							
23							
24							
25							
26							
27							
28							
29							
30							
31							
32							
33							
34							
35							
36							
37							
38							
39							
40							

A1 Initial Emergency Report Form



First On-Scene Actions

Evacuate	<input type="checkbox"/> Get to a safe area immediately. <input type="checkbox"/> Move upwind if release is downwind of you. <input type="checkbox"/> Move crosswind if a release is upwind from you. <input type="checkbox"/> Move to higher ground if possible.
Alarm	<input type="checkbox"/> Call for help ("Man Down"). <input type="checkbox"/> Sound bell, horn or whistle, or call by radio. <input type="checkbox"/> For medical emergencies, call 911.
Assess	<input type="checkbox"/> Take head count, locate any casualties. Consider all of the hazards. <input type="checkbox"/> Fill out information below to complete assessment.
Protect	<input type="checkbox"/> Put on breathing apparatus before attempting rescue.
Rescue	<input type="checkbox"/> Remove any casualties to a safe area.
First Aid	<input type="checkbox"/> Follow the standard first aid protocols at worksite. (CPR, etc.)
Medical Aid	<input type="checkbox"/> Arrange transport of casualties to medical aid. <input type="checkbox"/> Provide information to Emergency Medical Services (EMS).

Incident Details <i>To be completed by the person involved or notified</i>	
Report taken by	Date / Time
Name of person calling	Caller Telephone
Incident Location (LSD / NTS)	
Event Summary	
Agencies Notified <input type="checkbox"/> Yes Who? <input type="checkbox"/> No	
Event Status <input type="checkbox"/> Incident contained or controlled <input type="checkbox"/> Intermittent control possible <input type="checkbox"/> Imminent control possible <input type="checkbox"/> Incident is uncontrolled	
Site Type <input type="checkbox"/> Well <input type="checkbox"/> Pipeline <input type="checkbox"/> Tank Farm/Storage <input type="checkbox"/> Battery/Plant/Facility <input type="checkbox"/> Other _____	
Incident Type <input type="checkbox"/> Sour Gas Release <input type="checkbox"/> Sweet Gas Release <input type="checkbox"/> Pipeline Break <input type="checkbox"/> Security (theft, threat, terrorism) <input type="checkbox"/> Loss of Containment <input type="checkbox"/> Fire/Explosion <input type="checkbox"/> Worker Injury/Fatality <input type="checkbox"/> Vehicle/Transportation <input type="checkbox"/> Liquid Spill <input type="checkbox"/> Other _____	

A1 Initial Emergency Report Form



Impacts			
Public Health and Safety	<input type="checkbox"/> Could be jeopardized <input type="checkbox"/> Is jeopardized		
Public Protection Measures Taken	<input type="checkbox"/> Notification <input type="checkbox"/> Evacuation <input type="checkbox"/> Shelter-in-place <input type="checkbox"/> Roadblocks		
Worker Injuries	<input type="checkbox"/> First Aid <input type="checkbox"/> Hospitalized <input type="checkbox"/> Fatality <input type="checkbox"/> Other _____		
Distance to nearest surface development	_____ km	Distance to nearest urban centre	_____ km
Details			
Release Impact	<input type="checkbox"/> On-Lease <input type="checkbox"/> Off-Lease Product _____		Amount _____
Gas Readings	H ₂ S _____ SO ₂ _____ LEL _____ Other _____		
Distance to nearest watercourse	_____ km	Weather Conditions	
Details			
Media Involvement?	<input type="checkbox"/> Yes <input type="checkbox"/> No	Regulator Involvement?	<input type="checkbox"/> Yes <input type="checkbox"/> No
		Public Affairs/Community Relations Issues?	<input type="checkbox"/> Yes <input type="checkbox"/> No
Details			
Notes / Instructions Provided:			

Distribute this completed report to all Key Response Personnel

Note: Ensure the First On-Scene Actions have been completed before proceeding to the Five Step Initial Response Guide.

A2 Odour Complaint Script



Investigation of Complaints

When receiving an odour complaint call, document as much applicable information as possible so the company representative investigating it can do so safely.

Complaints will be prioritized based on level of perceived hazard to the public.

Company representatives will be dispatched to investigate complaints received by outside sources (member of the public, 3rd party company, etc.). If H₂S is suspected, personnel should be dispatched in teams of two (2). Any company representative who is to investigate a complaint must be trained and prepared to assume the role of Incident Commander if any of the emergency conditions are met.

Once a complaint has been investigated, the company must report the results of the investigation to the outside source who alerted the company about the situation.

Date:	Prepared by:
Time: <input type="checkbox"/> a.m. <input type="checkbox"/> p.m.	Duration of call:

To help us understand your immediate needs, we need to know:

<p><i>Name:</i> _____</p> <p><i>Contact number:</i> _____</p> <p><i>Description of the concern:</i> _____</p> <p>_____</p> <p>_____</p>
<p>How many people are you with right now?</p> <p><i>Adults</i> _____ <i>Children</i> _____</p>
<p>Can you provide the location of the incident?</p> <p><i>Location of the incident (address, legal, landmark, etc.):</i> _____</p> <p>_____</p>
<p>Where are you right now?</p> <p><input type="checkbox"/> Home / Work <input type="checkbox"/> In a Vehicle <input type="checkbox"/> Outside <input type="checkbox"/> Other _____</p> <p><i>If the resident is at home / work / outside tell them:</i></p> <p>The company will send someone to investigate. To be safe, you and anyone that you may be with need to go inside and stay inside. Close all doors and windows and turn off any appliances that blow out indoor air (i.e. clothes dryer) or suck in outside air (i.e. heating / air conditioning). Do not go outside or attempt to start any vehicles until you are told it is safe to do so.</p> <p><i>If the resident is in a vehicle and cannot shelter-in-place tell them:</i></p> <p>The company will send someone to investigate. To be safe, you and anyone that may be with you need to get inside the vehicle and stay inside. Keep all doors and windows closed and shut off the air conditioning / heat. If you see or hear anything that might indicate where the incident is occurring, travel in the opposite direction of the hazard; otherwise, continue travelling on your current course which will likely take you out of the hazard area.</p> <p>Someone will call you back with further instruction so please stay off of the phone so that we can contact you. If you have any urgent questions please call the company at _____.</p>



A3 First Call Communication



Contact Details	Regulatory Contact		Field Centre		
	Caller				Phone
	Notification	Date	Time	Release	Start Time End Time <input type="checkbox"/> Ongoing
	Licensee				Phone
	Location			Nearest Town	
	Nearest Resident	Distance/Direction			Phone
	Media Involvement?	<input type="checkbox"/> Local	<input type="checkbox"/> National	Media Contact	
		<input type="checkbox"/> Regional	<input type="checkbox"/> International		
Operator				Phone	
Public Impact	Public Health and Safety		<input type="checkbox"/> Could be jeopardized	Worker Injuries	<input type="checkbox"/> First Aid <input type="checkbox"/> Fatality
			<input type="checkbox"/> Is jeopardized		<input type="checkbox"/> Hospitalization
	Emergency Assessment Matrix completed with licensee		<input type="checkbox"/> Minor <input type="checkbox"/> Two	ERP Activated?	<input type="checkbox"/> Site Specific <input type="checkbox"/> Corporate
			<input type="checkbox"/> One <input type="checkbox"/> Three		<input type="checkbox"/> Field/Area
EPZ Size (2 km if unknown)		Numbers and Types of Public in EPZ		EOC/ICP Location	
Public Protection Measures Implemented		<input type="checkbox"/> Notification	<input type="checkbox"/> Roadblocks	Number Evacuated	
		<input type="checkbox"/> Shelter	<input type="checkbox"/> Evacuation		
Release Type	Release Impact		<input type="checkbox"/> On lease	<input type="checkbox"/> Off lease	H ₂ S Concentration
	<input type="checkbox"/> Sensitive Environment	Environment Affected	<input type="checkbox"/> Air	<input type="checkbox"/> Standing Water	Water Body Name
				<input type="checkbox"/> Land	<input type="checkbox"/> Flowing Water
	Area Affected (m ³)	<input type="checkbox"/> Property Damage	<input type="checkbox"/> Equipment Loss	<input type="checkbox"/> Wildlife / Livestock Affected	
	Gas Release	<input type="checkbox"/> Sweet	<input type="checkbox"/> Sour	Volume/Rate	
	Liquid Release	<input type="checkbox"/> Oil	<input type="checkbox"/> Water	<input type="checkbox"/> Effluent	Volume/Rate
<input type="checkbox"/> Release Point Determined					
Containment	Third Party / Outside Assistance Required		<input type="checkbox"/> Incident contained or controlled	<input type="checkbox"/> Imminent control probable	
			<input type="checkbox"/> Intermittent control possible	<input type="checkbox"/> Incident is uncontrolled	
Company			WCSS Co-op		
Operations Type	Well Licence No.	Type of Incident	<input type="checkbox"/> Kick	<input type="checkbox"/> Blowout	<input type="checkbox"/> Loss of Circulation
	Well Status	<input type="checkbox"/> Drilling	<input type="checkbox"/> Servicing	<input type="checkbox"/> Producing	<input type="checkbox"/> Injection
		<input type="checkbox"/> Standing	<input type="checkbox"/> Sweet	<input type="checkbox"/> Sour	<input type="checkbox"/> Critical
	Pipeline Licence No.	Line No.	<input type="checkbox"/> Hit	<input type="checkbox"/> Leak	<input type="checkbox"/> Rupture
Production Facility Licence No.	<input type="checkbox"/> Gas	<input type="checkbox"/> Gas Plant	<input type="checkbox"/> Compressor	AENV Approval No.	
	<input type="checkbox"/> Oil	<input type="checkbox"/> Battery	<input type="checkbox"/> Other		

A3 First Call Communication



Air Monitoring	<input type="checkbox"/> License Air Monitoring Occurring <input type="checkbox"/> Mobile <input type="checkbox"/> Handheld			Estimated Time of Arrival		
	Initial Readings / Location		<input type="checkbox"/> PPB <input type="checkbox"/> On Site <input type="checkbox"/> PPM <input type="checkbox"/> Off Site	Distance		
	Contractor Name		Phone	AMU Phone		
	Wind	Direction	Speed	Meteorological Conditions	AMU ETA	
Communications	Communications completed by Licensee and /or Regulatory Agency					
	<input type="checkbox"/> RCMP/Police	<input type="checkbox"/> Energy Regulator	<input type="checkbox"/> Emergency Management Agency	<input type="checkbox"/> TDG	<input type="checkbox"/> OH&S	<input type="checkbox"/> WCB
	<input type="checkbox"/> Ambulance	<input type="checkbox"/> Local Authority	<input type="checkbox"/> Ministry of Transportation	<input type="checkbox"/> CANUTEC	<input type="checkbox"/> DFO	<input type="checkbox"/> WCSS
	<input type="checkbox"/> Fire	<input type="checkbox"/> Health Authority	<input type="checkbox"/> Environment & Climate Change Canada (ECCC)	<input type="checkbox"/> ERAC	<input type="checkbox"/> Other	<input type="checkbox"/> Other
<input type="checkbox"/> CER	<input type="checkbox"/> First Nations	<input type="checkbox"/> Indian Oil & Gas	<input type="checkbox"/> Other	<input type="checkbox"/> Other	<input type="checkbox"/> Other	
Contact Names & Phone Numbers						
Incident Cause <input type="checkbox"/> Natural <input type="checkbox"/> Human-Induced unintentional <input type="checkbox"/> Human-Induced Intentional						
Other Information	<input type="checkbox"/> First Nations Band	Band / Settlement Name / Contact			Phone	
	<input type="checkbox"/> Metis Settlement					
	Complaints	<input type="checkbox"/> Local <input type="checkbox"/> Large area				
	Private Land Title holder				Phone	
Additional Information						

A4 Incident Action Plan Checklist



IAP Checklist Items:	Comments:
<input type="checkbox"/> ICS 202 – Incident Objectives	
<input type="checkbox"/> ICS 207 – Incident Organizational Chart	
<input type="checkbox"/> ICS 209 – Incident Status Summary	
<input type="checkbox"/> ICS 215 – Operational Planning Worksheet	
<input type="checkbox"/> ICS 215A – IAP Safety Analysis	
<input type="checkbox"/> ICS 230 – Meeting Schedule	
<input type="checkbox"/> ICS 233 – Incident Open Action Tracker	
<input type="checkbox"/> Map: _____	
<input type="checkbox"/> Map: _____	
<input type="checkbox"/> Other: _____	
<input type="checkbox"/> Other: _____	
<input type="checkbox"/> Other: _____	
Notes:	



A5 Air Monitoring Log



Date: _____	Responder Name: _____
Page _____ of _____	Responder Position: _____

Time	Location of Samples	H ₂ S (ppm)	LEL (%)	O ₂ (%)	SO ₂ (ppm)	Other	Temp (°C)	Wind Conditions *		Comments
								From	Speed (km/hr)	

*Estimate meteorological conditions where accurate readings are not available.

A6 Threatening Call / Bomb Threat



Date:	Time Call Received:	Time Call Reported:		
Person Receiving Call:		What/Whom Call Directed To:		
Caller's Sex: <input type="checkbox"/> Male <input type="checkbox"/> Female <input type="checkbox"/> Unknown		Approximate Age:		
Accent: <input type="checkbox"/> Yes <input type="checkbox"/> No Type:		Familiar voice: <input type="checkbox"/> Yes <input type="checkbox"/> No Who:		
Threat (Exact Wording):				
<p>Tips:</p> <ul style="list-style-type: none"> Listen carefully and remain calm. Do not interrupt caller. Attempt to keep caller talking. Attempt to ask questions below. Obtain as much information as you can while call is in progress. Signal someone to call your supervisor; give him / her this information. Do not hang up or disconnect your phone, even after the caller hangs up. For telephone tracing, call the local telephone company and local police. 				
If bomb threat, ask the following questions:				
When will the bomb go off? <i>(date and time)</i>				
Where is it located?				
Why did you place it?				
What kind of bomb is it?				
What does it look like?				
What is your name?				
Where are you calling from?				
Was the caller familiar with company facilities, or employees? (e.g.: nicknames, familiarity with staff, etc.) <input type="checkbox"/> Yes <input type="checkbox"/> No				
Did caller appear familiar with building / facility by the description of the bomb location? <input type="checkbox"/> Yes <input type="checkbox"/> No				
Identifying Characteristics of Caller				
Voice	Speech	Language	Manner	Background
<input type="checkbox"/> Loud	<input type="checkbox"/> Fast	<input type="checkbox"/> Excellent	<input type="checkbox"/> Calm	<input type="checkbox"/> Office Machines
<input type="checkbox"/> Soft	<input type="checkbox"/> Slow	<input type="checkbox"/> Good	<input type="checkbox"/> Angry	<input type="checkbox"/> Factory Machines
<input type="checkbox"/> High Pitched	<input type="checkbox"/> Distinct	<input type="checkbox"/> Fair	<input type="checkbox"/> Rational	<input type="checkbox"/> Street Traffic
<input type="checkbox"/> Deep	<input type="checkbox"/> Distorted	<input type="checkbox"/> Poor	<input type="checkbox"/> Irrational	<input type="checkbox"/> Airplanes
<input type="checkbox"/> Raspy	<input type="checkbox"/> Stutter	<input type="checkbox"/> Foul Language	<input type="checkbox"/> Coherent	<input type="checkbox"/> Trains
<input type="checkbox"/> Pleasant	<input type="checkbox"/> Nasal	<input type="checkbox"/> Accent	<input type="checkbox"/> Incoherent	<input type="checkbox"/> Animals
<input type="checkbox"/> Intoxicated	<input type="checkbox"/> Slurred	<input type="checkbox"/> _____	<input type="checkbox"/> Deliberate /	<input type="checkbox"/> Party Atmosphere
<input type="checkbox"/> _____	<input type="checkbox"/> _____	<input type="checkbox"/> _____	<input type="checkbox"/> Serious	<input type="checkbox"/> Music
Notify proper authorities as soon as possible. Have employees take a look around their immediate work stations for unusual packages. Evacuate building if necessary.			<input type="checkbox"/> Emotional	<input type="checkbox"/> Voices
			<input type="checkbox"/> Laughing	<input type="checkbox"/> Quiet
			<input type="checkbox"/> Nervous	<input type="checkbox"/> _____
Name of the supervisor first notified:				





STARS® * **LANDING ZONE INFORMATION CARD.**



*** STEP 1**
Advise your dispatch centre which channel you will be using to communicate with STARS.

*** STEP 2**
Select an area for the landing zone that is downwind from the incident site (unless hazardous materials or gases are present).



*** STEP 3** Select an area for the landing zone that is a minimum of 72 metres (or 236 feet, or 72 paces) from the incident site.



72 METERS
(236 FEET OR 72 PACES)



*** STEP 4** Select a flat, level surface for the landing zone; preferably pavement or concrete, if available.



*** STEP 5**
Ensure the landing zone area is clear of wires, poles, trees and debris.



*** STEP 6** Mark out a 36 metre by 36 metre (120 feet x 120 feet, or 36 paces x 36 paces) square, and mark the corners with LED beacons, heavy pylons or any other bright conspicuous objects easily seen from the air.

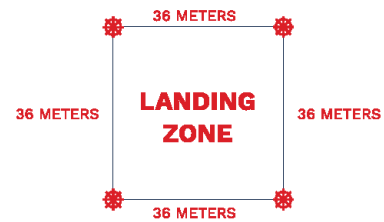

*** STEP 7**
Brief STARS crew via radio or cell phone and stand at the middle of the upwind side of the landing zone with the wind at your back.

Monitor radio frequency to communicate with the STARS team.

As the helicopter approaches, go down on one knee and DO NOT MOVE from your position.

Do not approach the helicopter at any time unless escorted by the STARS crew.

LANDING ZONE HAND SIGNALS

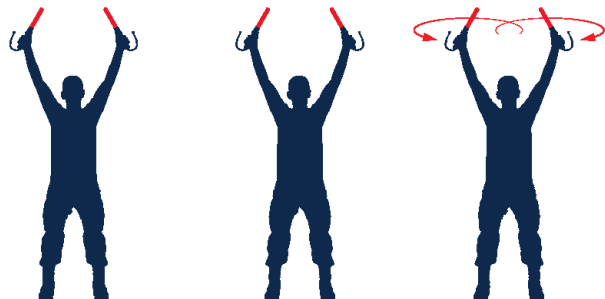

ALL CLEAR TO LAND ALL CLEAR TO DEPART ABORT LANDING



STARS® * **LANDING ZONE BRIEFING FOR STARS CREW.**



* **STEP 1**

Identify yourself and confirm the Landing Zone Officer is present with the landing zone secure.

* **STEP 2**

Communicate the location of the landing zone using N/E/S/W to reference the accident scene or other landmarks.

* **STEP 3**

Identify the type of surface for the landing zone (field, road, other).

* **STEP 4**

State what marking the corners of the landing zone: LED beacons, heavy pylons or any other bright conspicuous objects easily seen from the air.

* **STEP 5**

Communicate the wind direction and approximate speed.

* **STEP 6**

Identify the hazards in the area of the landing zone such as wires, poles, trees, or hazardous materials using N/E/S/W in reference to the landing zone.

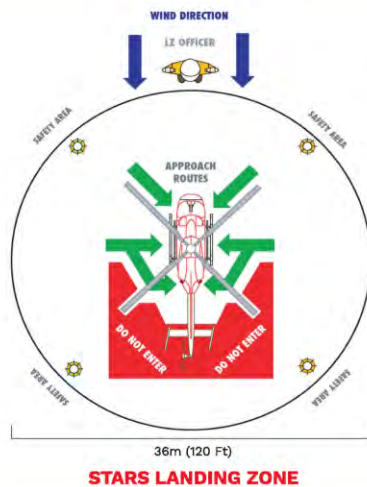

SPECIAL CONSIDERATION

Remove any loose debris and indicate if there is snow or dust in the landing zone. If dusty, water down the landing zone if possible prior to the helicopter's arrival. As marshaller, maintain your position at the middle of the upwind side of the landing zone, knees and **DO NOT MOVE** from your position as the helicopter lands.

If you have any questions or comments regarding this landing zone information card or would like to watch our landing zone video, please visit www.stars.ca



INDUSTRY EMERGENCY LINE 1-888-888-4567

This number can also be used to provide a landing briefing to the STARS crew if radio communications are not available.

WE ARE ALL STARS®

B1 Reception Centre Registration Log



Due to travel and time constraints, the company may not always be able to have a company employee at the Reception Centre before evacuees begin arriving. In this case this cover page can be included with the forms on the next 2 pages and sent to a representative at the Reception Centre to provide them with guidance on how to register and track evacuees until a company representative arrives.

Evacuee registration guidelines

[Insert Company Name] requires your assistance with receiving evacuees at the following Reception Centre: _____

Your company contact is:

Name: _____ Position: _____ Contact Number: _____ Fax Number: _____

- 1) Record all evacuees as they arrive on the forms provided.
- 2) Provide all evacuees with the statement below and any other status updates as provided by your company contact.
- 3) Provide the evacuees with food and lodging as required.
- 4) Record if any evacuees choose to leave the Reception Centre (name, contact number, where are they going, etc.).
- 5) Continually update the company of any residences arriving at or leaving the Reception Centre so that they can follow up on any residents that are unaccounted for.

B2 Resident Compensation Log



Resident's Name:	Home Address:	Home Telephone #:	Location of Land (LSD):
		Business Telephone #:	
Number of Residents Evacuated:	Evacuated to:	Telephone # While Evacuated:	

No.	Date	Location	Trans.	Accom.	Meals	Phone	Sundry	Total	Details of Expense
Total Reported Expenses									

Approved By: _____

Date: _____

B2 Resident Compensation Log



Resident's Name:	Home Address:	Home Telephone #:	Location of Land (LSD):
		Business Telephone #:	
Number of Residents Evacuated:	Evacuated to:	Telephone # While Evacuated:	

No.	Date	Location	Trans.	Accom.	Meals	Phone	Sundry	Total	Details of Expense
Total Reported Expenses									

Approved By: _____

Date: _____

B3 Resident Contact Log



Date: _____ Responder Name: _____

Page _____ of _____ Responder Position: _____ Responders Phone No.: _____

Time	Resident name	Resident ID	Shelter / Evacuate	Number of people		Assistance or transportation required?	Comments
				Inside	Outside		
			<input type="radio"/> Shelter <input type="radio"/> Evacuate			<input type="radio"/> Yes <input type="radio"/> No	
			<input type="radio"/> Shelter <input type="radio"/> Evacuate			<input type="radio"/> Yes <input type="radio"/> No	
			<input type="radio"/> Shelter <input type="radio"/> Evacuate			<input type="radio"/> Yes <input type="radio"/> No	
			<input type="radio"/> Shelter <input type="radio"/> Evacuate			<input type="radio"/> Yes <input type="radio"/> No	
			<input type="radio"/> Shelter <input type="radio"/> Evacuate			<input type="radio"/> Yes <input type="radio"/> No	
			<input type="radio"/> Shelter <input type="radio"/> Evacuate			<input type="radio"/> Yes <input type="radio"/> No	
			<input type="radio"/> Shelter <input type="radio"/> Evacuate			<input type="radio"/> Yes <input type="radio"/> No	
			<input type="radio"/> Shelter <input type="radio"/> Evacuate			<input type="radio"/> Yes <input type="radio"/> No	
			<input type="radio"/> Shelter <input type="radio"/> Evacuate			<input type="radio"/> Yes <input type="radio"/> No	
			<input type="radio"/> Shelter <input type="radio"/> Evacuate			<input type="radio"/> Yes <input type="radio"/> No	
			<input type="radio"/> Shelter <input type="radio"/> Evacuate			<input type="radio"/> Yes <input type="radio"/> No	

B3 Resident Contact Log



Time	Resident name	Resident ID	Shelter / Evacuate	Number of people		Assistance or transportation required?	Comments
				Inside	Outside		
			<input type="radio"/> Shelter <input type="radio"/> Evacuate			<input type="radio"/> Yes <input type="radio"/> No	
			<input type="radio"/> Shelter <input type="radio"/> Evacuate			<input type="radio"/> Yes <input type="radio"/> No	
			<input type="radio"/> Shelter <input type="radio"/> Evacuate			<input type="radio"/> Yes <input type="radio"/> No	
			<input type="radio"/> Shelter <input type="radio"/> Evacuate			<input type="radio"/> Yes <input type="radio"/> No	
			<input type="radio"/> Shelter <input type="radio"/> Evacuate			<input type="radio"/> Yes <input type="radio"/> No	
			<input type="radio"/> Shelter <input type="radio"/> Evacuate			<input type="radio"/> Yes <input type="radio"/> No	
			<input type="radio"/> Shelter <input type="radio"/> Evacuate			<input type="radio"/> Yes <input type="radio"/> No	
			<input type="radio"/> Shelter <input type="radio"/> Evacuate			<input type="radio"/> Yes <input type="radio"/> No	
			<input type="radio"/> Shelter <input type="radio"/> Evacuate			<input type="radio"/> Yes <input type="radio"/> No	
			<input type="radio"/> Shelter <input type="radio"/> Evacuate			<input type="radio"/> Yes <input type="radio"/> No	
			<input type="radio"/> Shelter <input type="radio"/> Evacuate			<input type="radio"/> Yes <input type="radio"/> No	
			<input type="radio"/> Shelter <input type="radio"/> Evacuate			<input type="radio"/> Yes <input type="radio"/> No	

B4 Roadblock Log



Date: _____ Responder Name: _____

Page _____ of _____ Responder Position: _____ Responders Phone No.: _____

Only emergency responders should be allowed to enter the Emergency Planning Zone (EPZ).

Vehicle Type	License plate # and province / state	Name of driver (if available)	# of people in vehicle	Time entering Zone	Time Exiting Zone	Comments (record all vehicles turned away)

B4 Roadblock Log



Vehicle type	License plate # and province / state	Name of driver (if available)	# of people in vehicle	Time entering zone	Time Exiting zone	Comments (record all vehicles turned away)



DATE: _____

TIME: _____

EVACUATION NOTICE

[Insert Company Name] has an emergency at its nearby location.

**As a safety precaution, please leave the area in a
(north / east / south / west) direction and proceed to the
Reception Centre located at**

_____.

[Insert Company Name] representatives will be available at the Reception Centre to address your questions or concerns.

For assistance, call *[Insert Company Name]* at

_____.

Thank you for your cooperation.



B6 Early Notification / Voluntary Evacuation Phone Message



Before calling, determine a safe evacuation route for the residents to travel, away from the emergency hazard area, upwind if possible, towards the reception centre.

<p>Hello, this is _____ (<i>your name</i>) _____ calling from _____ (<i>company name</i>) _____ .</p> <p>Is this the _____ (<i>name of residence / business</i>) _____ at _____ (<i>telephone number</i>) _____ ?</p> <p>_____ (<i>company name</i>) _____ is responding to a (<i>potential</i>) emergency at _____ (<i>location</i>) _____ in your area.</p> <p>You are in no danger at this time. All efforts are being made to resolve the problem and this phone call is only to inform you and provide you with an early notification.</p> <p>To help us understand and your immediate needs we need to know:</p>
<p>How many people are at your location now?</p> <p><i>Adults</i> _____</p> <p><i>Children</i> _____</p>
<p>Do you wish to leave your residence at this time?</p> <p>If Yes Please travel in a <u>north / east / south / west</u> direction to our reception centre located at: _____</p> <p>If No Please standby for further contact. Please do not use your telephone for outgoing calls as this may prevent us from contacting you with updated information or when the problem has been eliminated.</p>
<p>If you have urgent questions, please contact _____ (<i>company name</i>) _____ at _____ (<i>telephone number</i>) _____ .</p> <p>Thank you for your cooperation.</p>

(Pass on all information regarding this call to the Public Safety Group Supervisor immediately)

B6 Early Notification / Voluntary Evacuation Phone Message



B7 Shelter-In-Place Phone Message



Hello, this is _____ (*your name*) _____ of _____ (*company name*) _____.

Is this the _____ (*name*) _____ residence at _____ (*telephone number*) _____?
_____ (*company name*) _____ is responding to a (*potential*) emergency at _____ (*location*) _____ in your area.

For your safety, it is extremely important that you, and those with you, stay indoors until the potential hazard no longer exists, or you are advised to evacuate.

To help us understand your immediate needs, we need to know:

How many people are at your location now?

Adults _____

Children _____

Is there anyone in your household that you cannot contact to inform them of the situation and advise them to get in doors or stay out of the area?

Yes No

If Yes *Whom?* _____

Location of the person(s) _____

We will send someone to find them as soon as possible.

Do you have children in school at this time?

Yes No

If Yes *What school?* _____

Children's names _____

We will contact the school to ensure the safety of your children. Buses will be directed to leave the area immediately. If school is in session, your children will be redirected to the reception centre by their regular bus driver when the school day is over.

Do you have the "Shelter-in-Place" instructions previously provided to you by _____ (*company name*) _____?

Yes No

If Yes Please follow the Shelter-in-Place instructions located inside the resident pamphlet.

If No *Verbally walk the resident through the Shelter-in-Place instructions on the next page.*

Do you understand what I have told you?

Is there an alternate number we can contact you at? _____

If you have any urgent questions, please contact _____ (*company name*) _____ at _____ (*telephone number*) _____.

Thank you for your cooperation.

(Pass on all information regarding this call to the Public Safety Group Supervisor immediately)



Shelter-In-Place Instructions

For your safety:

- Immediately gather everyone indoors and stay there
- Close and lock all windows and outside doors
 - If convenient, tape the gaps around the exterior door frames
- Leave open all inside doors
- Extinguish indoor wood burning fires
 - If possible, close flue dampers
- Turn off appliances or equipment that either:
 - Blows out or uses indoor air, such as:
 - Bathroom and kitchen exhaust fans
 - Built-in vacuum systems
 - Clothes dryers
 - Gas fireplaces and gas stoves
 - Sucks in outside air, such as:
 - Heating, ventilation and air conditioner (HVAC) systems for apartments, commercial or public facilities
 - Fans for heat recovery ventilators or energy recovery ventilators (HRV / ERV)
- Turn down furnace thermostats to the minimum setting and turn off air conditioners
- Avoid using the telephone, except for emergencies, so that you can be contacted by company emergency response personnel
- Call the company emergency numbers you have been provided:
 - If you are experiencing symptoms or smelling odours (so that we can address your concerns and adjust our response priorities)
 - If you have contacted fire, police or ambulance (so that we can coordinate our response)
- Stay tuned to local radio and television for possible information updates
- Do not leave your residence, even if you see people outside, until you are told to do so
- After the hazardous substance has passed through the area you will receive an “all-clear” message from the company emergency response personnel. You may also receive, if required, instructions to:
 - Ventilate your building by opening all windows and doors; turning on fans and turning up thermostats. During this time the air outside may be fresher and you may choose to leave your building while ventilating.
 - Once the building is completely ventilated return all equipment to normal settings & operation.
- Do not leave your sheltered location or attempt to start any vehicle until a company representative advises you that the area is safe.

If you are unable to follow these instructions, please notify company emergency response personnel.

B8 Evacuation Phone Message



Before calling, determine a safe evacuation route for the residents to travel, away from the emergency hazard area, upwind if possible, towards the reception centre.

Hello, this is _____ <i>(your name)</i> _____ of _____ <i>(company name)</i> _____.	
Is this the _____ <i>(name)</i> _____ residence at _____ <i>(telephone number)</i> _____?	
_____ <i>(Company name)</i> _____ is responding to a <i>(potential)</i> emergency at _____ <i>(location)</i> _____ in your area.	
For your safety, it is extremely important that you and your family leave your residence immediately and travel in a <i>north / east / south / west</i> direction to our reception centre located at: _____	
To help us understand your immediate needs, we need to know:	
How many people are at your location now?	
<i>Adults</i> _____	
<i>Children</i> _____	
Is there anyone in your household that you cannot contact to inform them of the situation and advise them to evacuate away from the area?	
<input type="checkbox"/> Yes <input type="checkbox"/> No	
If Yes	<i>Whom?</i> _____
	<i>Location of the person(s)</i> _____
We will send someone to find them as soon as possible.	
Do you have children in school at this time?	
<input type="checkbox"/> Yes <input type="checkbox"/> No	
If Yes	<i>What school?</i> _____
	<i>Children's names</i> _____
We will contact the school to ensure the safety of your children. Buses will be directed to leave the area immediately. If school is in session, your children will be redirected to the reception centre by their regular bus driver when the school day is over.	
Do you require evacuation / transportation assistance?	
<input type="checkbox"/> Yes <input type="checkbox"/> No	
If Yes	We are sending someone to assist you. Please stay indoors and close all doors and windows until a Rover or the local police arrive to evacuate you.
If No	<i>Provide the resident with:</i>
	<input type="checkbox"/> <i>Directions to safely travel to the reception centre</i>
	<input type="checkbox"/> <i>A list of items to bring with them to the reception centre (medications, cell phone, etc.)</i>
	<input type="checkbox"/> <i>An idea of how long they may be expected to stay at the reception centre</i>
	<input type="checkbox"/> <i>The option to bring their house pets to the reception centre</i>
Please contact _____ <i>(company name)</i> _____ if you are unable to make it to the reception centre for any reason. Please keep your phone line free so that we can contact you if necessary.	
Is there an alternate number we can contact you at? _____	
A company representative at the reception centre will address any questions you may have and will make arrangements for your temporary accommodations. Do you understand everything I have told you? Are you leaving immediately?	
If you have any urgent questions, please contact _____ <i>(company name)</i> _____ at _____ <i>(telephone number)</i> _____.	
Thank you for your cooperation.	

(Pass on all information regarding this call to the Public Safety Group Supervisor immediately)



C1 Preliminary Media Statement



Date:(YY/MM/DD)	Responder Name:
Responder Position:	Responder Phone No.:

This is the information I can give you so far:

At (time – 24hr local clock) on (date), a(n) (fire, explosion, gas release, spill) occurred at the Company's (location name) site, located (distance) kilometres (east / west / north / south) of (nearest town or city).

Presently, (number of personnel) workers are being treated for injuries. The names and condition of the injured cannot be released until their families have been contacted.

The (well site, plant, pipeline, office, drilling location) has been (shut down, isolated, or is still flowing).

Company staff have been activated and are directing emergency response procedures to protect the public, our workers and the environment.

The cause of the (fire, explosion, gas release, spill) is not yet known and no estimate of damage is available. As information becomes available, news releases will be issued from the Information Office.

Any further inquiries should be directed to the Emergency Support Team, who will issue a press release at a later time.

Contact:

_____ Office: _____

_____ Fax: _____

*Note: Only the **Media Spokesperson** designated by the Emergency Support Team is to provide any specific information to the public or the media. Refer to page 3 of Section 3: Communications & Media for the generic media statement to be used by all other response personnel.*







Appendices

Appendix A: ERP Scope, Training and Plan Maintenance.....	1
Scope	1
Plan Objectives.....	1
Purpose	1
HSE Policy.....	3
Training Requirements.....	5
Plan Maintenance	6
Appendix B: Incident Command Post (ICP)	9
Communication Methods Between Command Posts - Saskatchewan.....	9
ICP Activation and Setup	10
Appendix C: Toxic Gases.....	12
Hydrogen Sulphide (H ₂ S)	12
Sulphur Dioxide (SO ₂).....	18
Appendix D: Key Elements of the Incident Command System (ICS)	23
Management by Objectives.....	23
Unity and Chain of Command.....	23
Organizational Flexibility	24
Span of Control.....	24
Common Terminology.....	24
Incident Action Plan (IAP)	24
Integrated Communications.....	24
Establishment and Transfer of Command.....	25
Resources Management	25
Summary of Responsibilities	25
Appendix E: Land Descriptions	26
Dominion Land Survey (DLS) System	26
National Topographic System (NTS)	27
Appendix F: ERP Reference Material.....	28
Acronyms.....	28
Glossary of Terms.....	29



This page is intentionally left blank



Appendix A: ERP Scope, Training and Plan Maintenance

Scope

This plan defines the emergency response process related to all hazards affecting petroleum operations. This Emergency Response Plan (ERP) outlines the process for an Alert/Minor, Level-1, Level-2, or Level-3 emergency for any jurisdiction or incident type.

Plan Objectives

The primary objective of this Emergency Response Plan (ERP) is to define the incident management system and organizational structure, process and tools to respond effectively to all incidents regardless of size or complexity. It has been designed to be intuitive and have natural process flow utilizing the Incident Command System (ICS) and to comply with applicable regulations, standards, and industry best practices.

Purpose

This ERP clearly defines emergency response team roles, functions and duties to protect people, environment, and assets during an incident. This plan clarifies the following:

- Overall Incident Command System (ICS) response organization.
- Incident Command System (ICS) Roles and responsibilities.
- Guidance to determine the Alert or Emergency Level.
- Mechanisms to activate the ERP.
- Notification /communication requirements to stakeholders (public /government /responders).
- Documentation tools for accurate records management of events and decisions during an event.
- Guidance for post-emergency actions.

The intent of this Emergency Response Plan (ERP) is to define effective measures in place to:

- Notify and protect the workers and the public.
- Minimize environmental impact.
- Minimize asset and property loss.
- Regain steady state of operations.
- Minimize emergency response time.
- Maximize response effectiveness.
- Coordinate with government agencies and stakeholders.
- Minimize business and reputational impact.

This manual outlines the framework, tools and reference materials to facilitate a prompt, safe, efficient and properly managed response to all incidents regardless of size or complexity. Therefore this plan provides employees and contractors with practical tools that will guide them through the Preparedness and Response principles of Emergency Management.

Emergency Management Process Flow

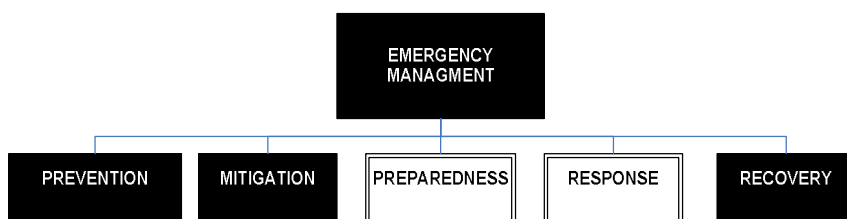



CORPORATE HEALTH, SAFETY AND ENVIRONMENTAL (HSE) POLICY

Steel Reef Infrastructure Corp.'s HSE culture is built on a foundation of value through:

- **Visible leadership** and commitment to a safe workplace, from senior management to the front-line;
- Ensuring all workers **understand the workplace risks**, are well-trained to manage those risks, and communicate consistently as a team;
- Expecting individuals to **take responsibility** for their own safety as well as for the safety of others.

It is the goal of Steel Reef Infrastructure Corp. to ensure that practical and effective measures are used to:

- Protect the health and safety of the company's employees, contractors, and the public.
- Safeguard the environment.
- Comply with all relevant Health, Safety and Environmental (HSE) and Damage Prevention legislation.
- Commit to continuously improve its HSE performance.

Everyone who works for Steel Reef Infrastructure Corp. (Steel Reef) shares the responsibility for workplace health and safety. Management and Supervisors have an additional responsibility to lead by example and are actively involved in the communication and implementation of the Company's HSE and Damage Prevention Program activities. Management will also ensure that the necessary equipment, training and procedures required for compliance with applicable legislation are provided.

All personnel are expected to comply with the rules and procedures as identified in applicable legislation and company documentation, as well as participate in the development of the Company HSE and Damage Prevention Program initiatives. Workers who knowingly violate safety rules will face disciplinary action.

Everyone has the right and responsibility to identify and refuse unsafe work. All hazards, potential hazards, incidents, and near-misses that occur on a Steel Reef worksite are expected to be reported. Workers will not face disciplinary action for reporting hazards, potential hazards, incidents, and near-misses.

A joint effort by management, employees and contractors is expected from all involved to maintain good and continuously improving safety, health and environmental performance.

Austin Voss
Chief Operating Officer

22-January-2019

Date



Appendix A: ERP Scope, Training and Plan Maintenance, continued

Training Requirements

Frequency / Action	As Required	Semi-Annually	Annually*	Every Three (3)	Every Five (5) Years***
Training					
Employee Orientation New / Transfer	✓				
On-the-job Training	✓				
Response Discussion During Pre-Job Meetings	✓				
Drills	✓				
Tabletop Exercise			✓ one of these exercises		
Communication / Partial Mobilization Exercises					
Major (Full Scale) Exercise	✓ Start-up of facility or transmission line (OGC)			✓	✓
Post Incident (Actual) Review	✓				
ERP Review / Self Audit		✓			

* Must be held annually.

** CSA Z246.2-18, CER, OGC & AER requires Major Exercises be held every three (3) years.

*** Environment & Climate Change Canada (ECCC) requires Major Exercises be held every five (5) years for facilities with E2 required substances.



Appendix A: ERP Scope, Training and Plan Maintenance, continued

Plan Maintenance

Responsibility

The licensee is responsible to ensure that an ERP is created for all provincial and federally regulated oil and gas activities (i.e. sour operations, HVP pipelines, cavern storage facilities, etc.), they are maintained regularly, and any updates are disseminated to the regulatory agency and other plan holders as required. In order for this to occur the following responsibilities are designated:

- Each individual plan holder is responsible for ensuring their assigned manuals are current, all updates are applied / downloaded / inserted, and any errors or omissions are reported to a supervisor.
- Each Area Manager is responsible for ensuring that a semi-annual review of their ERP is conducted. The ERP Revision Request Form is located in this section and can be used to track this information and provide documentation in the case of an ERP assessment.
- Any requests for revisions to this plan should be forwarded to the applicable Area Manager for review. These revisions will be discussed with the company's Emergency Response Program Coordinator and H₂Safety Services Inc. Any significant changes including those resulting from exercises and incidents will require immediate updates sent out to all plan holders; less significant changes will be implemented during the ERP's next annual update.
- The company's Emergency Response Program Coordinator is responsible for ensuring that the plans and distribution lists are updated, training is performed, and new projects are included in the plan. Information in this plan will be verified and updated at least once a year.
- Old manuals must be sent to H₂Safety Services Inc. or destroyed. If a plan holder no longer requires their manual (job changes, position changes, etc.), it must be returned to the company's Emergency Response Program Coordinator to be tracked, reassigned, or destroyed.

The licensee must distribute changes in information that are instrumental to implementing the ERP to all required plan holders.

Errors identified in the ERP by the regulatory agency, licensee, and other party must be corrected immediately upon identification.

Modifications to New or Existing Operations

The licensee must submit a supplement for review and approval to the regulatory agency for all newly added wells, pipelines, well / pipeline tie-ins, facilities and operating areas prior to commencement of operations if there are new surface developments within the Emergency Planning Zone. For example, the EPZ for a new pipeline tie-in does not fall entirely within the existing Emergency Planning Zone and impacts a new residence / public facility / trapper cabin / etc. that was not previously included in the Emergency Response Plan. The licensee must conduct a public involvement program for all new members of the public. Before any new or major modifications to an existing facility / pipeline are brought on-stream, any additions or changes will be added to the Emergency Response Plan. If required, a site specific Emergency Response Plan will be developed. Meetings to review response plan requirements must be held before major facility modifications are commissioned.



Appendix A: ERP Scope, Training and Plan Maintenance, continued

ERP Revision Request Form

Plan Holder Name / Title / Company: _____

ERP Name: _____

Manual Number: _____

If any of the following items have changed, please check the box beside it and provide a description of the change in the space provided:

- Company information
- Mapping information
- Resident contact information
- Response staff information or capacity changes
- Facility additions, such as well or pipeline tie-ins
- Other

Description of the change:

Please attach additional pages and/or support documentation as required.

Please return the completed checklist to:

H₂Safety Services Inc.
210, 7260 – 12 Street SE
Calgary, AB T2H 2S5
Email: erp@h2safety.ca
Fax: 403-313-9180



Appendix B: Incident Command Post (ICP)

Communication Methods Between Command Posts - Saskatchewan

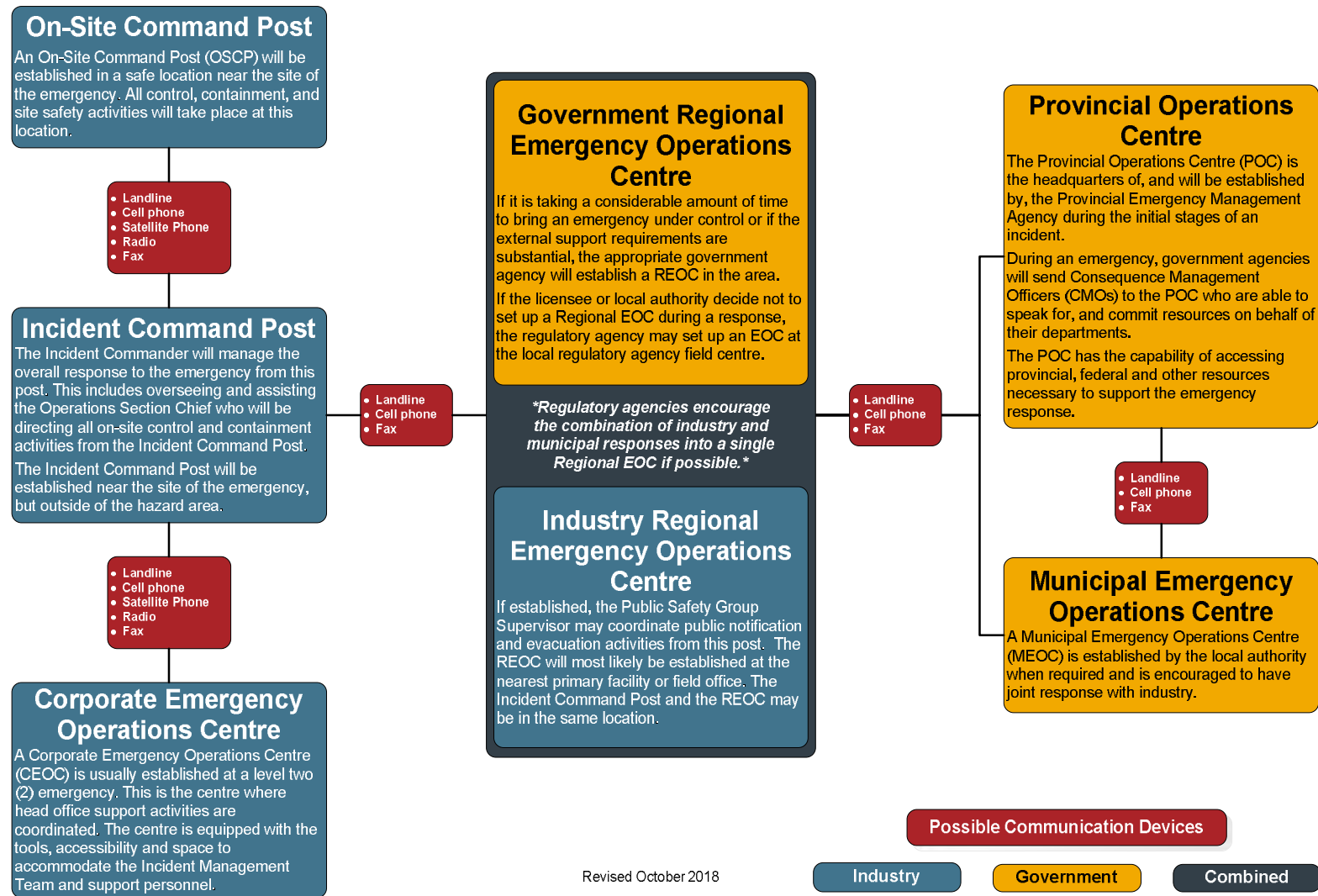

Revised October 2018



Appendix B: Incident Command Post (ICP), continued

ICP Activation and Setup

The Incident Command Post is activated by the Incident Commander.

The following tasks must be addressed once the ICP has been activated:

Position	Task
Incident Commander	<ul style="list-style-type: none"><input type="checkbox"/> Establish briefings with the Field Response Team (FRT).<input type="checkbox"/> Ensure staffing is adequate for the task(s).<input type="checkbox"/> Consider the time difference, if applicable, and determine how time will be communicated throughout the incident.
Safety Officer	<ul style="list-style-type: none"><input type="checkbox"/> Ensure the room / floor / building is secure.<input type="checkbox"/> Ensure a safe work area, i.e. remove clutter or cords causing slips, trips, falls, etc.
Information Officer	<ul style="list-style-type: none"><input type="checkbox"/> Notify the receptionist that there is an incident. Provide details of what message should be given out to the public and media, as well as where to direct incoming calls.<input type="checkbox"/> Ensure inbound and outbound calls received or made are centrally logged.<input type="checkbox"/> Ensure responders have their office phones forwarded to their cell phones.
Logistics / IT Support	<ul style="list-style-type: none"><input type="checkbox"/> Turn on all computers; ensure the relevant systems are operational and that they all have internet/email access.<input type="checkbox"/> Bring up any ERP related electronic tools (ie; H₂CommandCentre) and ensure they are working and that they can all be displayed on various projectors / screens as required.<input type="checkbox"/> Check that printers are connected to the computers and working. Print a test page to confirm.<input type="checkbox"/> Check that the fax machine is setup and working.<input type="checkbox"/> Check that any phone conferencing systems are set up and working.<input type="checkbox"/> Ensure that telephone lines are available and active.<input type="checkbox"/> Ensure TVs are working properly and set up to local news or CNN.<input type="checkbox"/> Obtain any additional equipment as required.
Logistics / Security	<ul style="list-style-type: none"><input type="checkbox"/> Ensure the room/floor/building is secure. Arrange for additional security if required.<input type="checkbox"/> If the location of the Incident Command Post is closed to general staff, provide a list of staff needing access clearance to the meeting area.<input type="checkbox"/> The following supplies should be available: notepaper, pens, printer cartridges and paper, documentation forms, dry erase markers, staplers and staples, spare power bars and extension cords, etc.<input type="checkbox"/> Arrange for refreshments (coffee, food, water, etc.) for those working there, as well as sleeping space if required.<input type="checkbox"/> Ensure there are sufficient tables and chairs for the team.



Appendix B: Incident Command Post (ICP), continued

ICP Activation and Setup, continued

Position	Task
Planning / Documentation	<ul style="list-style-type: none"><input type="checkbox"/> Determine which emergency response plans and other ERP tools are needed and pull them out to be readily accessible.<input type="checkbox"/> Determine what laminated maps and charts are going to be utilized and put them up on the wall with dry erase markers. Set up the white boards and roles chart.<input type="checkbox"/> Ensure clocks are displaying the correct time, including any clocks with a different time zone.<input type="checkbox"/> As each person arrives: provide them with a vest, provide them with a print out of the Initial Emergency Report Form, ensure they synchronize their watches and ensure they check in with their assigned supervisor.<input type="checkbox"/> As team members arrive, write their name in the appropriate position on the Field Response Team Assignment Chart.<input type="checkbox"/> Pass out documentation forms and provide an overview of the documentation process.<input type="checkbox"/> Ensure the latest contact list for Field Response Team members are available.<input type="checkbox"/> Begin documenting all actions, decisions and major events. Start-up H₂CommandCentre if available.<input type="checkbox"/> Continually update the laminated maps and charts as information becomes available (Field Response Team Assignment Chart, Emergency Status Board, etc.).<input type="checkbox"/> Post a schedule of events, including shift changes and status updates.

Incident Command Post Briefings

Once the ICP has been activated and team members arrive, the Incident Commander or Deputy needs to conduct an initial briefing to provide the team with the status of the situation, establish operational periods for the ICP, establish a meeting schedule for both a planning meeting and periodic briefings and outline broad goals to guide the ICP throughout the emergency.

In addition to periodic briefings for status updates, the Incident Commander also has to conduct a meeting once the approved Incident Action Plan is in place. This meeting will outline the planned objectives and tasks and will ensure that resources required for implementation of the action plan are in available or en route.

At the end of each operational period, all departing members of the Field Response Team will be debriefed and must brief their replacements.

Documentation

It is critical to ensure that all ICP documentation is compiled, properly stored and readily available after the event. Proper documentation will aid in investigations, inquiries, debriefs and support for financial claims and budgets. Everything that happens during the Response/Recovery Operations should be recorded at the ICP. The forms at the back of this manual are designed to aid in this process.



Appendix C: Toxic Gases

Hydrogen Sulphide (H₂S)

Background

Hydrogen sulphide (H₂S) is a flammable, colourless gas with a characteristic odour of rotten eggs that people can smell at low levels. It is also known as hydrosulphuric acid and sewer gas. H₂S occurs naturally in crude petroleum, natural gas, volcanic gases and hot springs. It can also result from bacterial breakdown of organic matter. Industrial sources include emissions from industrial paper plants; combustion of coal, fuel oil and natural gas (including gas flares); kraft paper mills; tanneries; and emissions from sewers and waste treatment facilities. Cigarette smoke is also a source of hydrogen sulphide.

H₂S is released primarily as a gas and spreads in the air. Its residence time in the atmosphere ranges from about one day to more than 40 days, depending on ambient temperature and other atmospheric variables, including humidity, sunshine and presence of other pollutants. The decreased temperatures and decreased levels of hydroxyl ions in northern regions in winter increase the residence time. When released H₂S gas is ignited, it will change into sulphur dioxide (SO₂), be carried into the atmosphere and dispersed over a larger area at lower concentrations.

Signs and Symptoms

Exposure to hydrogen sulphide may cause irritation to the eyes, nose or throat. It may also cause difficulty in breathing for some asthmatics. Brief exposures to high concentrations of hydrogen sulphide can cause a loss of consciousness and possibly death. In most cases, the person appears to regain consciousness without any other effects. However, in some individuals, there may be permanent or long-term effects such as headaches, poor attention span, poor memory and poor motor function. No health effects have been found in humans exposed to typical environmental concentrations of hydrogen sulphide (0.00011-0.00033 ppm).

Acute Exposure Effects

The effects on humans will vary depending on the duration and H₂S concentration of exposure. The health effects of acute exposure to H₂S are shown in the following table. Acute exposure reflects a range from a few seconds up to several weeks.

Hydrogen Sulphide Toxicity Table (BC Regulations)

Concentration (ppm)	Effects
Less than 1	Most people smell "rotten eggs".
3 – 5	Odour is strong.
20 – 150	Nose and throat feel dry and irritated. Eyes sting, itch or water and "gas eye" symptoms may occur. Prolonged exposure may cause coughing, hoarseness, shortness of breath and runny nose.
150 – 200	Sense of smell is blocked (olfactory fatigue).
200 – 250	Major irritation of the nose, throat and lungs, along with headache, nausea, vomiting and dizziness. Prolonged exposure can cause fluid buildup in the lungs (pulmonary edema), which can be fatal.
300 – 500	Symptoms are the same as above, but more severe. Death can occur within 1-4 hours of exposure.
Above 500	Immediate loss of consciousness. Death is rapid, sometimes immediate.

Adapted from Hydrogen Sulfide in Industry, WorkSafe BC February 2010



Appendix C: Toxic Gases, continued

Acute Health Effects of Hydrogen Sulphide (AB Regulations)

Concentration in Air (ppm)	Description of Potential Health Effects
1	A noticeable odour that may be offensive to some individuals. People may temporarily experience mild symptoms of discomfort, including nausea, headache, and irritability due to the odour. Asthma symptoms may worsen.
10 – 20	An obvious offensive odour. Temporary eye irritation may occur after a single exposure and last several hours. Symptoms include mild itchiness, dryness, increased blink reflex and slight watering. Some people may experience headaches, nausea and vomiting. Symptoms of asthma, bronchitis or other forms of chronic respiratory disease may worsen.
50	A strong, intense offensive odour that may irritate eyes and breathing passages. Eyes may be itchy, stinging, and red with increased blinking, tearing and tendency to rub eyes. Breathing passages could feel tingly or sting, with increased tendency to clear throat and cough. Symptoms of pre-existing respiratory disease may worsen. No permanent injury to eyes or breathing passages is expected unless exposure is prolonged. Odour-sensitive individuals may experience headaches, nausea, vomiting and diarrhea.
100	Initially there is a strong objectionable odour that lessens with prolonged exposure due to olfactory "fatigue." Eyes and breathing passages are often irritated within one hour of exposure. Eyes may be sore, stinging, burning, tearing, redness, swelling of eyelids, and possible blurred vision. Respiratory irritation may include sore throat, cough, soreness or stinging of breathing passages, and wheezing. The symptoms of asthma, bronchitis or other forms of chronic respiratory disease will worsen. Odour may cause headache, nausea, vomiting and diarrhea.
250	There may or may not be an odour present due to olfactory paralysis. Eyes and breathing passages will become irritated within minutes of exposure, and the irritation will worsen with longer exposure. The outer surface of the eyes and inner eyelids will be inflamed, red and sore. Eyes will begin watering and tearing immediately and vision may be blurred. Eyes may be permanently harmed if exposure is prolonged. Respiratory irritation will include sore throat, cough, difficulty breathing, soreness of chest, and wheezing. Asthma symptoms will worsen. People may experience "systemic" effects, including headache, nausea and vertigo depending on duration of exposure.
500	No odour is present due to olfactory paralysis. Severe irritation and possible permanent injury to the eyes and breathing passages within 30 minutes of exposure. Lung and breathing passage damage may cause 'chemical pneumonia' following exposure if the exposure was prolonged. Systemic effects involving the central nervous system may occur within one hour of exposure and include headache, anxiety, dizziness, loss of coordination and slurred speech. People may lose consciousness or collapse suddenly, and die if exposure persists.



Appendix C: Toxic Gases, continued

Acute Health Effects of Hydrogen Sulphide (AB Regulations), continued

Concentration in Air (ppm)	Description of Potential Health Effects
750	No odour is present due to olfactory paralysis. Central nervous system effects will be most obvious, and could include anxiety, confusion, headache, slurred speech, dizziness, stumbling, loss of coordination, and other signs of motor dysfunction. People may lose consciousness, collapse suddenly and possibly die, if exposure continues for more than a few minutes. Lung and breathing passage damage will likely cause 'chemical pneumonia' among survivors.
1000	Immediate "knock-down" and loss of consciousness. Death within moments to minutes. Immediate medical attention needed if victim is to survive.

Adapted from: Technical Advisory Committee on Public Health and the Oil and Gas Industry, Environmental Public Health Manual for Oil and Gas Activities in Alberta, 2007

Source: Alberta Health Services, Environmental Public Health

<http://www.albertahealthservices.ca/assets/wf/eph/wf-eh-alberta-health-acute-exposure-health-effects-of-hydrogen-sulphide-and-sulphur-dioxide.pdf>



Appendix C: Toxic Gases, continued

Chronic Exposure Effects of Hydrogen Sulphide

Chronic effects from H₂S exposure is a developing area of research. Chronic exposure may inflame and irritate the upper respiratory tract.

Medical treatment for hydrogen sulphide exposure

(Please note: This information was provided by a medical source other than the Provincial Regional Health Authorities. See Hydrogen Sulphide (H₂S) Guidelines - Revised November 2000)

Guidelines for in Hospital Assessment/Treatment of Possible Hydrogen Sulphide Exposure

This is provided to assist medical staff in assessing a worker who has a possible or actual H₂S exposure.

Section I provides information on H₂S

Section II summarizes possible health effects, which should be evaluated at the time of presentation

Section III depicts a summary of possible clinical management

Section IV provides a guideline regarding return to work (RTW) considerations

I. Hydrogen sulphide

H₂S is a colourless gas. It is heavier than air and tends to flow in ditches, trenches and low-lying areas.

H₂S is clearly recognizable in small concentrations at around one part per million (ppm) by its characteristic rotten egg smell.

At concentrations of about 150 ppm in the air, or after prolonged exposure to lower concentrations, the olfactory sense is paralyzed and the presence of H₂S can no longer be detected by odour.

II. Health effects of hydrogen sulphide

H₂S can be rapidly fatal. It acts by paralyzing the respiratory control centre in the brain and by inhibiting cellular respiration.

Hydrogen sulphide is a mucous-membrane and respiratory-tract irritant. Pulmonary edema, which may be immediate or delayed, can occur after exposure to high concentrations.

Acute exposure may include the following symptoms and signs:

Central Nervous System

CNS injury is immediate and significant after exposure to hydrogen sulphide. At high concentrations, only a few breaths can lead to loss of consciousness, coma, respiratory paralysis, seizures, and death. CNS stimulation may precede CNS depression. Stimulation manifests as excitation, rapid breathing, and headache; depression manifests as impaired gait, dizziness, and coma, possibly progressing to respiratory paralysis and death. In addition, decreased ability to smell occurs at 100 to 150 ppm.

Respiratory

Inhaled Hydrogen sulphide initially affects the nose and throat. Low concentrations (50 ppm) can rapidly produce irritation of the nose, throat, and lower respiratory tract. Pulmonary manifestations include cough, shortness of breath, and bronchial or lung hemorrhage. Higher concentrations can provoke bronchitis and cause accumulation of fluid in the lungs, which may be immediate or delayed for 24 hours or more. Lack of oxygen may result in cyanosis.



Appendix C: Toxic Gases, continued

Medical Treatment for Hydrogen Sulphide Exposure, continued

Cardiovascular

High dose exposure may cause insufficient cardiac output, irregular heartbeat and conduction abnormalities.

Renal

Although very unlikely, transit renal effect may include blood, casts, and protein in the urine. Renal failure as a direct result of hydrogen sulphide toxicity has not been described, although it may occur secondary to cardiovascular compromise.

Gastrointestinal

Symptoms may include nausea and vomiting.

Dermal

Prolonged or massive exposure may cause burning, itching, redness and painful inflammation of the skin.

Ocular

Eye irritation may result in inflammation (i.e. kerato-conjunctivitis) and clouding of the eye surface. Symptoms include blurred vision, sensitivity to light, and spasmodic blinking or involuntary closing of the eyelid.

Potential Sequelae

Inflammation of the bronchi can be a late development. Survivors of severe exposure may suffer psychic disturbances and permanent damage to the brain and heart.

III. Approach to the worker with suspected hydrogen sulphide exposure

Although this document refers only to H₂S, it is important for the clinician to keep in mind the possibility of co-exposure to numerous other agents. Sulphur dioxide may have been present if there has been combustion of hydrogen sulphide. Sulphur dioxide does not cause loss of consciousness but is a respiratory tract irritant. Therefore, the management of sulphur dioxide intoxication is similar to that for hydrogen sulphide. Other agents capable of causing asphyxia include carbon monoxide (toxic asphyxia) as well as a wide array of gases that act as simple asphyxiants (carbon dioxide, methane, nitrogen, etc.) by displacing oxygen. Finally, other conditions (MI, syncope, seizure, etc.) that may cause sudden collapse must be investigated and managed as appropriate.

History

The history is the key to the diagnosis of hydrogen sulphide (or other industrial) intoxication. There are two facets to the history in such cases:

Exposure history: This attempts to define, in qualitative terms, the likelihood of, and amount of exposure to hydrogen sulphide. This should include questions about work processes, the presence of a rotten egg odour and inquiring as to effects in co-workers. If possible, this should be supplemented by Industrial Hygiene information, which might include the triggering of alarms for hydrogen sulphide and historical data on air measurements. For suspected exposures, the workplace can often provide useful estimates regarding the level of exposure, although such data may require several days to reconstruct.

Clinical history: The physician should attempt to establish the presence of as many of the symptoms as possible associated with H₂S exposure. Determining the presence of respiratory tract irritation (conjunctivitis, rhinitis, tracheitis) is of particular importance since this symptom distinguishes hydrogen sulphide from several other asphyxiants and serious toxicity is unlikely in the absence of this symptom at presentation.

Investigations

There are no specific tests in routine clinical use to establish hydrogen sulphide intoxication. Rather, testing is aimed at characterizing the sequels of intoxication, as well as to rule out other causes for the presentation.



Appendix C: Toxic Gases, continued

Medical Treatment for Hydrogen Sulphide Exposure, continued

Treatment

Treatment is entirely supportive in nature and includes supplemental oxygen, managing eye and skin exposure as a chemical burn and maintenance of circulatory status. Although nitrite therapy has been advocated as an antidote, there is little evidence to support its use and as it is potentially dangerous it is not recommended.

On arrival - check blood gases and assess for lactic acidosis. Take chest film and repeat as necessary keeping in mind the delayed possibility of pulmonary edema. ECG may assist as arrhythmias and bradycardia are not uncommon. Temporary T wave depression may occur and ECG may mimic infarction.

For the unconscious patient, give oxygen using mechanical ventilation with positive end expiratory pressure.

Assess for associated musculo-skeletal and internal traumatic injury.

Maintain circulating fluid volume, but be alert for delayed onset of pulmonary edema.

At times, strong physical restraint may be required. Keep the patient as inactive as possible.

A pulmonary function test should be done near time of discharge and, if abnormal should be repeated at appropriate intervals thereafter.

If symptoms and/or exposure history are strongly clinically suggestive, because of the possibility of delayed pulmonary edema, adequate monitoring and follow-up for at least 24 hours is essential.

IV. Guidelines for Return to Work (RTW)

Three possible scenarios may be considered by the attending medical personnel:

Possible exposure, without symptoms

Possible exposure, with symptoms (that are compatible with H₂S)

Known exposure including "knockdown", with symptoms that require medical treatment and/or hospitalization.

In each scenario, a clinical decision about appropriate medical investigations, treatment, follow-up evaluation, and timing of return-to-work (RTW) will have to be made. It is emphasized that with scenarios (1) and (2), it may be preferable to either monitor the employee in the hospital or as an outpatient (with follow-up examination) for 24-48 hours prior to RTW.



Appendix C: Toxic Gases, continued

Sulphur Dioxide (SO₂)

Background

Sulphur Dioxide (SO₂) belongs to the family of sulphur oxide gases (SO_x). Sulphur is prevalent in raw materials including crude oil and coal, as well as in ore that contains common metals. Sulphur oxide gases form when fuels containing sulphur are burned and when gas is processed or metals are extracted from ore. Like other sulphur oxide gases, SO₂ dissolves in water or water vapour to form acid, and interacts with other gases and particles in the air to form sulphates and other products.

Sulphur dioxide is a colourless gas that is about 2.5 heavier than air. It has a sweet pungent odour, and can be detected by taste and smell at concentrations as low as 300 parts per billion (ppb). Acids that are formed when SO₂ (and nitrogen oxides) react with other substances in the air may be carried great distances before falling to earth as rain, fog, snow or dry particles. Acid rain damages forests and crops, changes the chemical make-up of soils, and increases the acidity of lakes and streams. Continued long-term exposure will affect the natural variety of plants and animals in an ecosystem. As well as contributing to smog, SO₂ emissions cause aesthetic damage and accelerate the decay of building materials and paints.

General guidelines dictate evacuation where SO₂ concentrations reach 5 ppm averaged over a 15 minute period. However, as a precaution, evacuation will be established under the criteria when the SO₂ level reaches 1 ppm for two to three hours, or averages 0.3 ppm over twenty-four hours.

Signs and Symptoms

Sulphur dioxide causes a wide variety of health and environmental impacts because of the way it reacts with other substances in the air. Acute and chronic exposure to SO₂ affects the respiratory system. Acute exposure effects, with increasing exposure, include irritation of the eye, nose and throat, choking, coughing, bronchitis and pneumonia. Exposure to low concentrations can aggravate chronic pulmonary diseases, such as asthma and emphysema. Co-exposure to cold or dry air may further exacerbate the respiratory effects of SO₂ on sensitive asthmatics. Particularly sensitive groups include children, the elderly and those with existing heart or lung disease.

Sulphur Dioxide Toxicity Table (BC Regulations)

Concentration (ppm)	Effects
0.13	24 hour level (MWLAP Level B Criteria).
0.34	One hour average evacuation level (MWLAP Level B criteria).
2	Eight hour occupational Exposure Limit (BC WCB)
3 – 5	Odour threshold.
5	15 minute Occupational Exposure Limit (BC WCB)
8 – 12	Throat irritation, coughing, constriction in chest, tearing and smarting of the eyes.
10 – 50	5 – 15 minutes exposure produces increased irritation of eyes, nose, and throat, choking, coughing, and in some cases wheezing due to narrowing of the airways (which increases the resistance of the air flow).
150	Short-term endurance lost due to the severe eye irritation and because of the effects on the membranes of the nose, throat, and lungs.
500	Highly dangerous after exposure of 30 – 60 minutes.

Adapted from the Canada Safety Council Data Sheet "Sulphur Dioxide" No. B-4 Oil and Gas Commission November 2003.



Appendix C: Toxic Gases, continued

Acute Health Effects of Sulphur Dioxide (AB Regulations)

Concentration (ppm)	Acute Health Effects
0.1	Transient bronchoconstriction ¹ in sensitive exercising asthmatic individuals that ceases when exposure ceases. ²
0.3 – 1	Possible detection by taste or smell.
0.75	Transient lung function changes in healthy, moderately exercising, non-asthmatic individuals.
1 - 2	Lung function changes in healthy non-asthmatics. Symptoms in asthmatics would likely increase in severity. There may be a shift to clinical symptoms from changes detectable only via spirometry.
3	Easily detected odour.
6 – 12	May cause nasal and throat irritation.
10	Upper respiratory irritation, some nosebleeds.
20	Definitely irritating to the eyes; chronic respiratory symptoms develop; respiratory protection is necessary.
50 – 100	Maximum tolerable exposures for 30-60 minutes.
Greater than 100	Immediate danger to life (NIOSH recommendation).

¹ At low levels, bronchoconstriction was generally observed as changes in airway conductance detectable by spirometry rather than as clinical symptoms.

² It should be noted that clinical studies on humans are generally designed to elicit a response and consequently subject study volunteers to challenging conditions such as exercising, mouth breathing, cold, dry air, etc. Real-life responses in asthmatics should be viewed as being individual-specific dependent on severity of asthma, whether the individuals are medicated or not, how cold and/or dry the air is, mouth breathing (vs. nose breathing, which can act as an effective scrubber mechanism) and exercise.

Adapted from: Technical Advisory Committee on Public Health and the Oil and Gas Industry, Environmental Public Health Manual for Oil and Gas Activities in Alberta, 2007

Source: Alberta Health Services, Environmental Public Health

<http://www.albertahealthservices.ca/assets/wf/eph/wf-eh-alberta-health-acute-exposure-health-effects-of-hydrogen-sulphide-and-sulphur-dioxide.pdf>



Appendix C: Toxic Gases, continued

Medical treatment for sulphur dioxide exposure

(Please note: This information was provided by a medical source other than the Provincial Regional Health Authorities. See Sulphur Dioxide (SO₂) Guidelines - Revised July 2001)

Guidelines for in Hospital Assessment/Treatment of Possible Sulphur Dioxide Exposure

This is provided to assist medical staff in assessing a worker who has a possible or actual SO₂ exposure.

Section I provides information on SO₂

Section II summarizes possible health effects which should be evaluated at the time of presentation

Section III depicts a summary of possible clinical management

Section IV provides a guideline regarding return to work (RTW) considerations.

I. Sulphur Dioxide

SO₂ is a colourless gas with a pungent odour detectable by the human nose at concentrations of about 0.5 to 0.8 ppm.

SO₂ is highly soluble in water resulting in the formation of sulphurous acid.

Approximately 90% of inhaled SO₂ is absorbed in the upper respiratory tract.

Asthmatics and individuals with underlying bronchial hyperactivity may be more susceptible to low level exposure to SO₂.

II. Health Effects of Sulphur Dioxide

SO₂ causes almost immediate coughing with significant exposure.

SO₂ causes irritation of the conjunctive and nasal mucosa at levels between 5 and 10 ppm.

Exposures of SO₂ as low as 8 ppm has been associated with symptoms of cough, phlegm, wheezing and exertional dyspnea.

Acute high-dose exposures leading to severe injury are unusual, parenchyma lung damage occurs above 50 ppm.



Appendix C: Toxic Gases, continued

Medical treatment for sulphur dioxide exposure, continued

Acute exposure may include the following symptoms and signs:

Respiratory

Inhaled SO₂ is a moderate to strong respiratory irritant. Reddening of the throat and nose may occur. Repeated exposure to 10 ppm has caused nosebleeds. Sensitivity varies among people, short exposure to low concentrations may produce a reversible decrease in lung function, and symptoms may include chest tightness.

Exposure to high concentrations of SO₂ has caused severe airways obstruction, hypoxia and pulmonary edema. The effects of pulmonary edema include coughing and shortness of breath which can be delayed until hours or days after the exposure; these symptoms are aggravated by physical exertion. Survivors of high concentration exposures may suffer chemical bronchopneumonia and bronchiolitis obliterans, which can be fatal after a few days. Delayed chemical pneumonitis and bronchial asthma can also result.

Dermal

The gas will react with moisture on the skin and cause irritation (redness, itching).

Ocular

Eye irritation may result in smarting of the eyes and tearing. In severe cases (high concentrations in a confined area), SO₂ has caused temporary corneal burns.

Potential Sequelae

Survivors of high concentration exposures may suffer chemical bronchopneumonia and bronchiolitis obliterans, which can be fatal after a few days. Delayed chemical pneumonitis and bronchial asthma can also result.

III. Approach to the worker with suspected Sulphur Dioxide Exposure

Although this document refers only to SO₂, it is important for the clinician to keep in mind the possibility of co-exposure to numerous other agents.

History

The history is the key to the diagnosis of SO₂ (or other industrial) intoxication. There are two facets to the history in such cases:

Exposure history: This attempts to define, in qualitative terms, the likelihood of, and amount of exposure to sulphur dioxide. This should include questions about work processes, the presence of an odour and inquiring as to the effects in co-workers. If possible, this should be supplemented by industrial hygiene information which might include the triggering of alarms for sulphur dioxide and historical data on air measurements. For suspected exposures, the workplace can often provide useful estimates regarding the level of exposure, although such data may require several days to reconstruct.

Clinical history: The physician should attempt to establish the presence of as many of the symptoms as possible associated with SO₂ exposure.

Investigations

There are no specific tests in routine clinical use to establish sulphur dioxide intoxication. Rather, testing is aimed at characterizing the sequels of intoxication as well as to rule out other causes for the presentation.



Appendix C: Toxic Gases, continued

Medical treatment for sulphur dioxide exposure, continued

Treatment

Treatment is entirely supportive in nature and includes supplemental oxygen, managing eye and skin exposure as a chemical burn and maintenance of respiratory status.

On arrival - check blood gases. Take chest film and repeat as necessary keeping in mind the delayed possibility of pulmonary edema.

Oxygen should be delivered by nasal cannula or mask, or if pulmonary injury leads to severe hypoxia by mechanical ventilation.

If bronchospasm occurs, bronchodilators may be of value.

A pulmonary function test should be done near time of discharge and, if abnormal, should be repeated at appropriate intervals thereafter.

Conjunctival irritation should be treated with copious irrigation with saline and the eyes examined with fluorescein for corneal defects.

Assess for associated musculo-skeletal and internal traumatic injury.

Prophylactic antibiotics should be avoided.

If symptoms and/or exposure history are strongly clinically suggestive, because of the possibility of delayed pulmonary edema, adequate monitoring and follow-up for at least 24 hours is essential.

IV. Guidelines for Return to Work (RTW)

Three possible scenarios may be considered by the attending medical personnel:

Possible exposure, without symptoms;

Possible exposure, with symptoms (that are compatible with SO₂) or

Known exposure, including "knockdown", with symptoms that require medical treatment and/or hospitalization.

In each scenario, a clinical decision about appropriate medical investigations, treatment, follow-up evaluation and timing of return-to-work (RTW) will have to be made. It is emphasized that with scenarios (2) and (3), it may be preferable to either monitor the employee in the hospital or as an outpatient (with follow-up examination) for 24 - 48 hours prior to RTW.



Appendix D: Key Elements of the Incident Command System (ICS)

Management by Objectives – Objectives are ranked by priority, should be as specific as possible, must be attainable and if possible given a working time-frame. Objectives are accomplished by first outlining strategies (general plans of action), then determining appropriate tactics (how the strategy will be executed) for the chosen strategy

Unity and Chain of Command – Each individual takes direction from and reports to only one designated supervisor; this is called Unity of Command. Higher level personnel have authority over lower level personnel; the lower level personnel are subordinate to and take direction from higher level personnel. Orders and instructions travel down the chain of command from one supervisor to each subordinate. This is called Chain of Command.

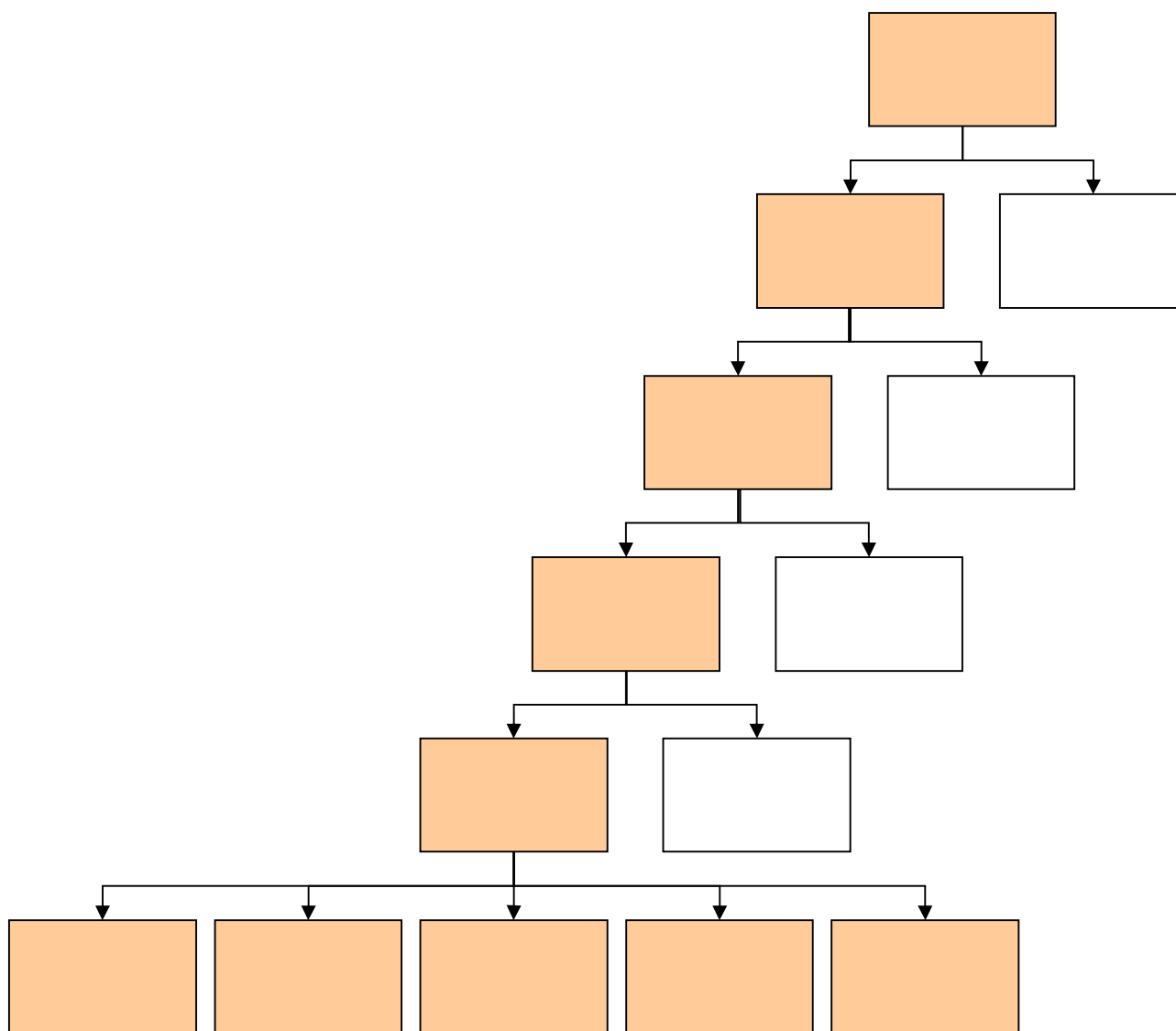

Appendix D: Key Elements of the Incident Command System (ICS), continued

Organizational Flexibility – Only positions that are required at the time should be assigned. In most cases, very few positions will need to be assigned.

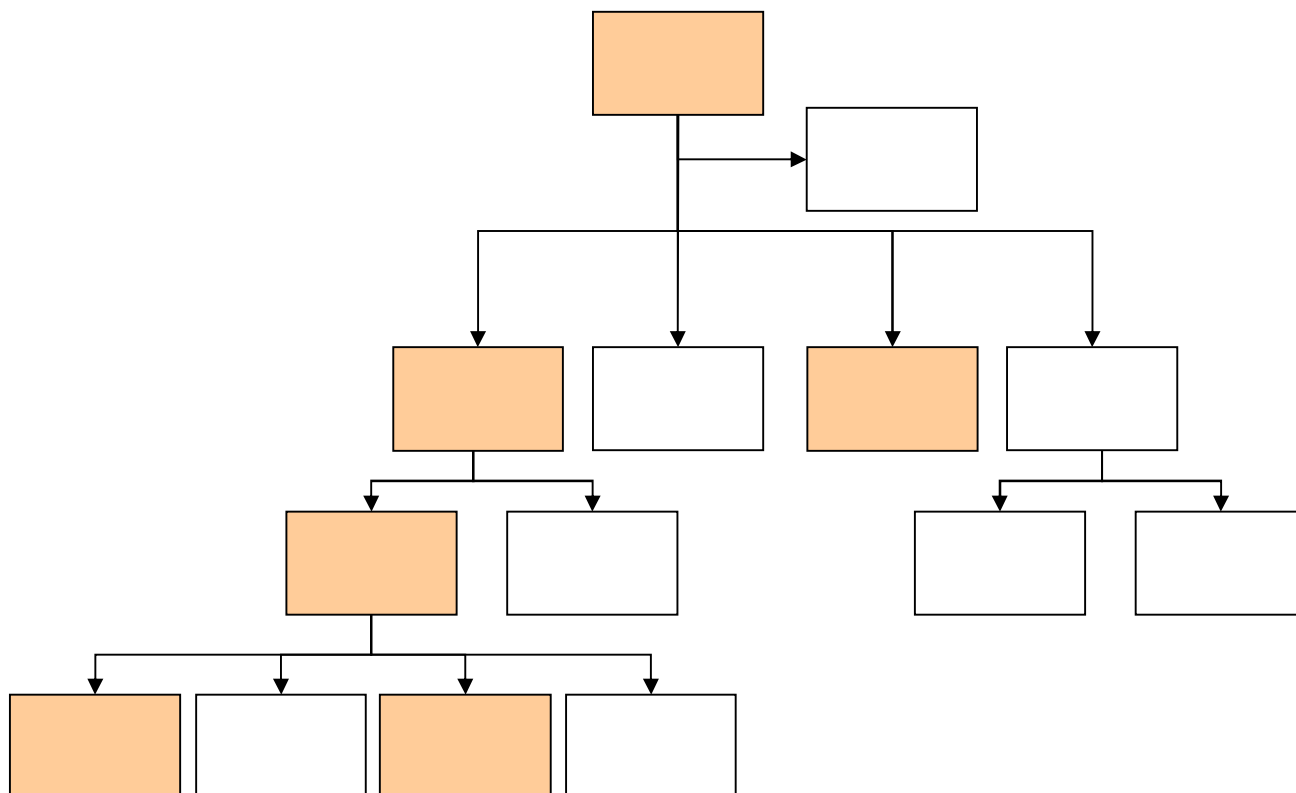

Span of Control – ICS requires that any single person's span of control (number of people reporting to them) should be between three and seven, with five being ideal.

Common Terminology – When different organizations are required to work together, the use of common terminology is essential.

Incident Action Plan (IAP) – Every incident must have a written or oral Incident Action Plan. The following information is part of an Incident Action Plan and must be communicated to the rest of the organization:

- Objectives, strategies and tactics outlined by the Incident Commander.
- Resources assignments – what resources do we have and what are they doing? What resources are on order and what are they going to do?
- A description of the ICS organizational structure – what positions will be filled?
- Supporting materials – incident map, communications plan, evacuation plan, stick diagrams, etc.

Integrated Communications – The use of a common communications plan is essential for ensuring effective communication during an incident.



Appendix D: Key Elements of the Incident Command System (ICS), continued

Establishment and Transfer of Command – The highest ranking authority arriving on-scene at an incident will assume the role of the Incident Commander. That person will continue to be the Incident Commander until there is a formal transfer of command. A transfer of command briefing usually consists of:

- Reviewing a description of the incident.
- Reviewing the actions taken thus far to contain and control the incident.
- Reviewing the current ICS organizational structure.
- A summary of the resources available and ordered.

Resources Management – A resource must either be in assigned, available, or out-of-service status.

- Assigned – a resource in assigned status is currently doing whatever tasks have been assigned to it.
- Available – a resource in available status is ready to be deployed at a moments notice. Resources in available status often wait for assignments at an incident Staging Area.
- Out-of-Service – a resources in out-of-service status might be sleeping, receiving medical aid, getting repairs, etc. and is not ready for assignment.

Summary of Responsibilities

These management functions are handled by the General Staff once they have been delegated by the Incident Commander.

Command Ensures safety. Assumes overall responsibility for the incident.

The Incident Commander is responsible for the Command of the incident as well as the following management functions until they are assigned to other response personnel:

Operations Implements the Incident Action Plan (IAP) focusing on control, containment, and site safety.

Public Safety Implements the Incident Action Plan (IAP) focusing on notification and evacuation of the public.

Planning Help create and track (document) the success of the Incident Action Plan (IAP).

Logistics Secure the resources and put them in place to allow Operations to implement the Incident Action Plan.

Finance/Admin Ensures procedures are in place to allow logistics to secure the resources (spending) and track and control the expenditures.

Communications Disseminates information and liaises with external agencies.

Communications is handled by the Information Officer once one has been appointed by the Incident Commander. The Information Officer is part of the Command Staff.



Appendix E: Land Descriptions

Dominion Land Survey (DLS) System

- Each township (6 mile x 6 mile) is divided into 36 sections (1 mile x 1 mile)
- Each section is divided into 16 legal sub-divisions (L.S.D.)
- Each section is divided into four quarters (N.W., N.E., S.W., and S.E.)

The numbering of sections and L.S.D.s is shown below:

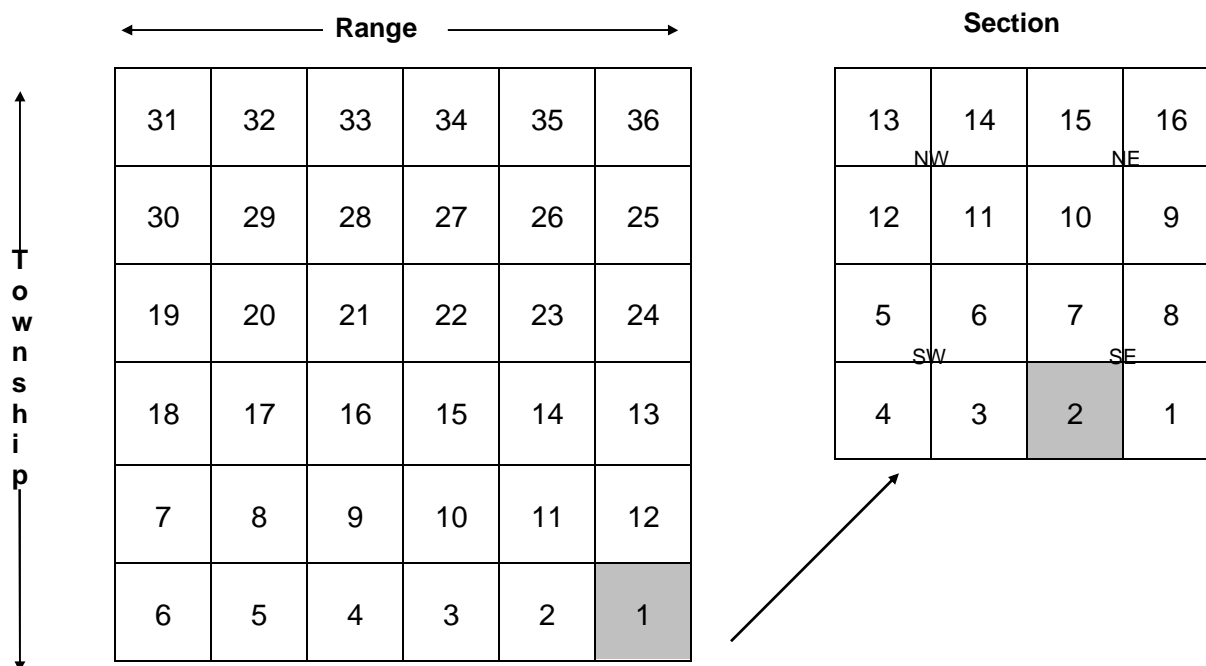

- Townships increase in number from South to North starting at the Canada - USA border
- Ranges increase in number from East to West within a Meridian. A Range is one (1) Township wide (6 miles).
- Meridians run from the North Pole to the South Pole and are spaced every four degrees. The principal Meridian in Canada originates in Central Manitoba and increases West or East from there.
- Legal land description is listed in the following order:

	<u>L.S.D</u>	-	<u>Section</u>	-	<u>Township</u>	-	<u>Range</u>	-	<u>Meridian</u>
Example	02	-	01	-	38	-	09	-	West of the 4 th



Appendix E: Land Descriptions, continued

National Topographic System (NTS)

Based on the National Topographic System (NTS), the map labelling terms are as follows:

1) Series	A rectangular area that has a width of 8 degrees of longitude and 4 degrees of latitude. There are 9 Series in British Columbia (82, 83, 92, 93, 94, 102, 103, 104, and 114).
2) Area	1/16 of a map Series that has a width of 2 degrees of longitude by 1 degree of latitude (labelled from A to P).
3) Sheet	1/16 of map Area that has a width of 30' in longitude and 15' of latitude (labelled from 1 to 16).
4) Block	1/12 of a map Sheet with a width of 7'30" in longitude and 5' in latitude (labelled from A to L).
5) Unit	1/100 of a map Block, and has a latitudinal extent of 30" and longitudinal extent of 45" (labelled from 1 to 100).
6) Quarter Unit	1/4 of a map Unit (labelled from a to d).

Note: 1 degree is equivalent to approximately 111 km in British Columbia. Degrees vary in size around the planet. They become smaller the closer they get to the poles (north or south) and very large as they reach the equator.

Example a-29-H / 93-P-9

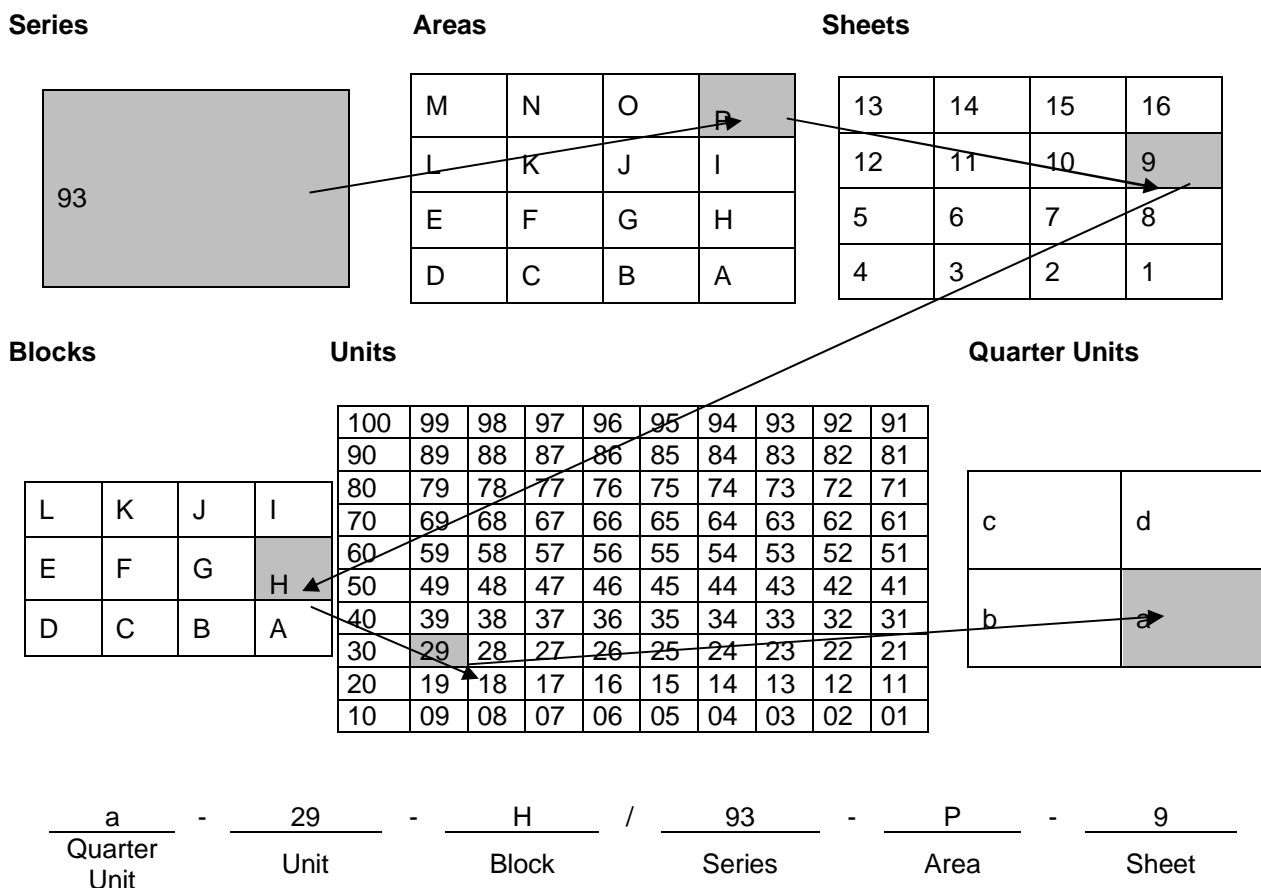



Appendix F: ERP Reference Material

Acronyms

Acronym	Meaning	Acronym	Meaning
ABSA	Alberta Boilers Safety Association	ICS	Incident Command System
AEMA	Alberta Emergency Management Agency	IIZ	Initial Isolation Zone
AER	Alberta Energy Regulator	INAC	Indigenous and Northern Affairs Canada
AH	Alberta Health	LA	Local Authority
AHS	Alberta Health Services	LBV	Line Block Valve
AT	Alberta Transportation	LEL	Lower Explosive Limit
BLEVE	Boiling Liquid Expanding Vapour Explosion	LPG	Liquefied Petroleum Gas
CANUTEC	Canadian Transport Emergency Centre	MARS	Mapping and Response System
CAPP	Canadian Association of Petroleum Producers	MD	Municipal District
CEPA	Canadian Environmental Protection Act	MEP	Municipal Emergency Plan
CER	Canada Energy Regulator	MOP	Maximum Operating Pressure
CERC	Corporate Emergency Response Centre	NGL	Natural Gas Liquids
CISD	Critical Incident Stress Debriefing	NOTAM	Notice to Airmen
CPE	Communications and Public Engagement	OGC	Oil & Gas Commission
CSA	Canadian Standards Association	OHS	Occupational Health and Safety
DFO	Department of Fisheries and Oceans	OSCAR	Oil Spill Containment and Recovery
EAZ	Emergency Awareness Zone	OSCP	On-Site Command Post
ECCC	Environment & Climate Change Canada	PAD	Protective Action Distance
EMBC	Emergency Management BC	PAZ	Protective Action Zone
EMO	Emergency Measures Organization	POC	Provincial Operations Centre
EOC	Emergency Operations Centre	PPB	Parts Per Billion
EPZ	Emergency Planning Zone	PPE	Personal Protective Equipment
ER	Ministry of Energy and Resources	PPM	Parts Per Million
ERAC	Emergency Response Assistance Canada	RCMP	Royal Canadian Mounted Police
ERP	Emergency Response Plan	RD	Rural District
ESD	Emergency Shut Down	REOC	Regional Emergency Operations Centre
ESDV	Emergency Shut-Down Valve	RHA	Regional Health Authority
ETA	Estimated Time of Arrival	RM	Rural Municipality
FH Order	Fire Hazard Order	SABA	Supplied Air Breathing Apparatus
FNIHB	First Nations and Inuit Health Branch – Health Canada	SCBA	Self-Contained Breathing Apparatus
GEOC	Government Emergency Operations Centre	SDS	Safety Data Sheet
HPZ	Hazard Planning Zone	SHA	Saskatchewan Health Authority
HVAC	Heating Ventilation Air Conditioning	SO ₂	Sulphur Dioxide
HVP	High Vapour Pressure	STARS	Shock Trauma Air Rescue Society
HVPL	High Vapour Pressure Liquid	TDG	Transportation of Dangerous Goods
H ₂ S	Hydrogen Sulphide	WCSS	Western Canadian Spill Service
IAP	Incident Action Plan	WHMIS	Workplace Hazardous Materials Information System



Appendix F: ERP Reference Material, continued

Glossary of Terms

Adjacent to

Within 25 m.

Air Quality Monitoring

Measurement of atmospheric concentrations of a hazardous substance, such as H₂S or SO₂.

Alberta Energy Regulator (AER)

The AER ensures the safe, efficient, orderly, and environmentally responsible development of hydrocarbon resources over their entire life cycle. This includes allocating and conserving water resources, managing public lands, and protecting the environment while providing economic benefits for Albertans.

Alert (Alberta specific)

An incident that can be handled on-site by the licensee through normal operating procedures and is deemed to be a very low risk to members of the public.

Auto-ignition temperature

All NGL products are flammable and will flash at extremely low temperatures. An open flame or spark is not necessary to cause ignition. Any hot surface which exceeds the auto-ignition temperature of a product can cause a fire if the vapours reaching the hot surface are within their flammable range.

Best practices

A technique or methodology that, through experience and research, has proven to reliably lead to a desired result. A commitment to using the best practices in any field is a commitment to using all the knowledge and technology at one's disposal to ensure success.

Body of water

Streams, lakes, and rivers.

Boiling Liquid Expanding Vapour Explosion (BLEVE)

Boiling Liquid Expanding Vapour Explosion, which is associated with natural gas liquids and high vapour pressure liquids.

Boiling point

This is the temperature that a liquid changes to a gas. NGL products change to a gas at extremely low temperatures and will absorb heat from the surrounding environment during the phase change. Therefore, caution must be used when working with NGLs because contact with flesh can reduce the temperature of the flesh to the NGL boiling point and cause severe frostbite.

British Columbia Oil and Gas Commission (OGC)

The OGC is the lead agency for all regulated oil and gas related activities within British Columbia.

British Columbia Emergency Management (EMBC) (*British Columbia specific*)

Aids local governments in analyzing hazards and risks, develop and test emergency plans, train and organize emergency staff and volunteers. EMBC also manages all agencies in the event of an emergency or disaster, which cannot be handled locally.

Businesses

Industrial operators, retail outlet operators, suppliers, residents, outfitters, foresters and other entities that normally operate within the Emergency Planning Zone, but do not necessarily reside in the Emergency Planning Zone.



Appendix F: ERP Reference Material, continued

Glossary of Terms, continued

Closure order (*British Columbia specific*)

When the OGC believes that, because of hazardous conditions in a field or at a well, it is necessary or expedient to close an area and to shut out all persons except those specifically authorized, the commission may make an order in writing setting out and delimiting the closed area. For Alberta see Fire Hazard (FH) Order.

Corporate Emergency Response Plan

This Emergency Response Plan is to facilitate a co-ordinated response by company executive and management personnel to an emergency situation, which may affect the company or its affiliated companies. The Corporate Emergency Response Plan is an integral part of all site-specific company Emergency Response Plans and procedures.

Critical Incident Stress Debriefing (CISD)

Critical Incident Stress Debriefing is a specially structured counselling process between the debriefers and those who are directly involved and/or impacted by an incident.

Critical sour well (*Alberta specific*)

A well with an H₂S release rate greater than 2.0 m³/s or wells with lower H₂S release rates in close proximity to an urban centre as defined in ID 97-6: Sour Well Licensing and Drilling Requirements.

Emergency

A present or imminent event outside the scope of normal operations that requires prompt coordination of resources to protect the health, safety, and welfare of people and to limit damage to property and the environment.

Emergency Operations Centre (EOC)

An Emergency Operations Centre is a designated facility in a suitable location (i.e. head office, regional office, etc.) established by the permit holder to support Incident Command and to manage the larger aspects of an emergency. In a high-impact emergency, there may be a number of EOCs established to support the response. They may include the Incident Command Post, regional and corporate EOCs, a municipal EOC (MEOC), and the provincial government EOC (POC).

Emergency Awareness Zone (EAZ) (*British Columbia specific*)

A distance outside of the EPZ where public protection measures may be required due to poor dispersion of the hazard. This area is twice the radius of the Emergency Planning Zone (EPZ).

Emergency Planning Zone (EPZ)

The geographical area that surrounds a well, pipeline or facility containing hazardous product that requires specific emergency response planning by the licensee.

Emergency Response Plan (ERP)

A comprehensive plan to protect the public that includes criteria for assessing an emergency situation and procedures for mobilizing response personnel and agencies and establishing communication and coordination among the parties.

Emergency Support Team (EST)

Provides advice and logistical support to the Field Response Team and Incident Commander in particular. The team is comprised of head office personnel and any contract emergency experts.

EOC Director

The EOC Director activates the Corporate Emergency Operations Centre with staff to provide advice and support to the Incident Commander (Field Response Team).



Appendix F: ERP Reference Material, continued

Glossary of Terms, continued

EOC Director, continued

Note: If the emergency happens outside an area that has a site specific Emergency Response Plan, only then will the EOC Director assume or appoint the role of Incident Commander and dispatch a Field Response Team to the incident site.

ERCBH2S (*Alberta specific*)

A software program that calculate site-specific EPZs using thermodynamics, fluid dynamics, atmospheric dispersion modelling and toxicology.

Evacuation

Organized, phased, and supervised withdrawal of members of the public from dangerous or potentially dangerous areas to safe areas.

Tactical Evacuation – A measure to immediately move people to a safe area as part of emergency response and operations. Does not require approval from local authority but the local authority may enact an evacuation order, if required, and local authority must be advised if a tactical evacuation has occurred.

Planned Evacuation – An evacuation coordinated by local government authority that can authorize evacuation alerts and orders.

Explosive Limits (Lower and Upper)

Each gaseous hydrocarbon substance has a minimum (Lower Explosive Limit or LEL) and a maximum (Upper Explosive Limit or UEL) percentage in air below or above which combustion will not take place. Explosive limit and flammability limit are used interchangeable. The terms "Too Lean" and "Too Rich" are used for levels outside of the explosive range.

Facility

Any building, structure, installation, equipment, or appurtenance that is connected to or associated with the recovery, development, production, handling, processing, treatment, or disposal of hydrocarbon-based resources or any associated substance or wastes. This does not include wells or pipelines.

Field Response Team (FRT)

Company and contractor personnel directly involved in controlling the incident at the emergency site and from the EOC.

Fire Hazard (FH) Order (*Alberta specific*)

An order issued by the AER during an emergency to restrict public access to a specified area.

Functional Exercise

As described in CAN/CSA Z246.2-18, an activity designed to evaluate capabilities and multiple functions using simulated response. A functional exercise will simulate the deployment of resources and rapid problem solving. Participants will evaluate management of the command and coordination centres and assess the adequacy of emergency response plans and resources.

Gathering system

The network of pipelines, pumps, tanks, and other equipment that carries oil and gas to a processing plant or to other separation equipment.

Hazard

A situation with potential to harm persons, property, or the environment.



Appendix F: ERP Reference Material, continued

Glossary of Terms, continued

Hazard Planning Zone (HPZ) (British Columbia specific)

A geographical area (a) determined by using the hazard planning distance as a radius, and (b) within which persons, property or the environment may be affected by an emergency. Defined in Emergency Management Regulation.

Hazardous product

A substance released in quantities that may harm persons, property, or the environment.

High Vapour Pressure Liquids (HVPLs)

HVPLs have a vapour pressure greater than 240 kPa at 38°C (34.8 PSIG @ 100°F) and include ethane, propane, butane, and pentanes plus, either as a mixture or as a single component.

Note: Comparisons

Gasoline - Vapour pressure between 55 and 100 kPa at 38°C (8 - 14.5 PSIG @ 100°F).

Condensate - Often a component of a propane/butane mixture, has a vapour pressure of 59 to 72 kPa at 38°C (8.6 - 10.4 PSIG @ 100°F).

High Vapour Pressure (HVP) plume dispersion geometry

An uncontrolled release of NGL product on flat terrain will form a vapour plume as it disperses. If the vapour plume formed at the leak site has not been ignited, it will most likely reach its maximum size within the first half hour of the leak occurrence. Two unique features of an NGL plume are:

The downwind edge of the plume tends to spread out significantly forming a broad frontal edge.

Under certain conditions, the plume will travel upwind for a short distance.

High Vapour Pressure (HVP) pipeline

A pipeline system conveying hydrocarbons or hydrocarbon mixtures in the liquid or quasi-liquid state with a vapour pressure greater than 110 kilopascals absolute at 38°C. Some examples are liquid ethane, ethylene, propane, butanes, and pentanes plus.

High Vapour Pressure (HVP) products

HVP products have a vapour pressure greater than 240 kPa at 38°C (34.8 PSIG at 100°F) and include ethane, propane, butane and pentanes plus, either as a mixture or as a single component. A leak from a vessel or pipe containing HVP products can result in a BLEVE.

Hydrogen sulphide (H₂S)

A naturally occurring gas found in a variety of geological formations and also formed by the natural decomposition of organic matter in the absence of oxygen. H₂S is colourless, has a molecular weight that is heavier than air, and is extremely toxic. In small concentrations, it has a rotten egg smell and causes eye and throat irritations. Depending on the particular gaseous mixture, gas properties, and ambient conditions, a sour gas release may be:

Heavier than air (dense), so it will tend to drop towards the ground with time,

Lighter than air (buoyant), so it will tend to rise with time, or

About the same weight as air (neutrally buoyant), so it will tend to neither rise nor drop but with time disperse.

Hydrogen sulphide (H₂S) release rate

The rate that sour gas escapes into the atmosphere is often calculated for sour gas wells. It is usually defined in cubic metres per second (m³/s). The size of the emergency planning zone is estimated from the H₂S release rate.



Appendix F: ERP Reference Material, continued

Glossary of Terms, continued

Hydrogen sulphide (H₂S) release volume

The volume of sour gas that escapes into the atmosphere is often calculated for facilities that have a defined retention volume, usually defined in cubic metres. Emergency planning zone sizes are often estimated using the volume of H₂S that may be released from a facility. More sophisticated models may also incorporate the rate at which the release could occur and the nature of the gas and the atmospheric conditions when determining the emergency planning zone size.

Hyper-susceptible

A person or persons who may be abnormally reactive to a given exposure to toxins and whose reaction may occur in orders of magnitude greater than that of the susceptible population. Hypersusceptibles include those persons with impaired respiratory function, heart disease, liver disease, neurological disorders, eye disorders, severe anemia, and suppressed immunological function.

Ignition

Process of setting a hydrocarbon release on fire.

Ignition Team

Consists of at least two personnel trained in plume ignition.

Incident

An unexpected occurrence or event that requires action by emergency personnel to prevent or minimize the impacts on people, property, and the environment.

Incident classification

A system that examines the risk level to members of the public following an incident and assigns a level of emergency based on the consequence of the incident and the likelihood of the incident escalating.

Incident Command Post (ICP)

A designated place where the Incident Commander and staff is located. The ICP should be located outside of the hazard area, but close to the incident. The ICP may be a vehicle, trailer, fixed facility or any location suitable to accommodate the function.

Incident Commander

Manages the overall response to emergency incidents. The Incident Commander is responsible for: developing objectives, strategies and tactics that guide the response; assigning personnel to fill necessary positions; ensuring the safety of all personnel; keeping internal and external stakeholders updated; coordinating with other response agencies.

Incident Command System (ICS)

A standardized, on-scene, all-hazard incident management system. The Incident Command System (ICS) is flexible in that it can be adapted for large and small incidents.

Initial Isolation Zone (IIZ)

An area in close proximity to a continuous hazardous release where indoor sheltering may provide limited protection due to proximity of release.

Incident Management System

A system used to coordinate preparedness and incident management.

Isolating the release

Ensuring access to the hazard area is controlled.



Appendix F: ERP Reference Material, continued

Glossary of Terms, continued

Level 1 Emergency (*Alberta specific*)

There is no danger outside the licensee's property, there is no threat to the public, and there is minimal environmental impact. The situation can be handled entirely by licensee personnel. There will be immediate control of the hazard. There is little or no media interest.

Level 1 Emergency (*British Columbia specific*)

There is no immediate danger to the public or environment as no H₂S has been released; the emergency is confined to the lease or company property.

Level 2 Emergency (*Alberta specific*)

There is no immediate danger outside the licensee's property or the right-of-way, but there is the potential for the emergency to extend beyond the licensee's property. Outside agencies must be notified. Imminent control of the hazard is probable but there is a moderate threat to the public and/or the environment. There may be local and regional media interest in the event.

Level 2 Emergency (*British Columbia specific*)

There is potential risk to the public or environment, as the emergency could extend beyond company property. However, control is still possible.

Level 3 Emergency (*Alberta specific*)

The safety of the public is in jeopardy from a major uncontrolled hazard. There are likely significant and ongoing environmental impacts. Immediate multi agency municipal and provincial government involvement is required.

Level 3 Emergency (*British Columbia specific*)

An immediate danger to the public or environment exists; control of the situation has been lost.

Licensee

The responsible duty holder as specified in legislation.

Liquid to gas expansion

NGL products will expand greatly when released to the atmosphere. For example, propane expands 272 times its liquid volume. Other products expand at different rates, but all have a high gas to liquid ratio.

Liquefied Petroleum Gas (LPG)

Mixture of heavier, gaseous hydrocarbons (butane and propane), liquefied as a portable source of energy.

Local Authority

A local authority is considered to be:

- 1) The council of a city, town, village or municipal district;
- 2) in the case of an improvement district or special area, the Minister of Municipal Affairs;
- 3) for a national park, the park superintendent or the park superintendent's delegate;
- 4) the settlement council of a Métis settlement; or
- 5) the band council of a First Nations Reserve.

Local State of Emergency

See State of local emergency.

Lower Explosive Limit (LEL)

The lowest concentration of gas or vapour (per cent by volume in air) that explodes if an ignition source is present at ambient temperatures.



Appendix F: ERP Reference Material, continued

Glossary of Terms, continued

Manitoba Growth, Enterprise & Trade – Petroleum Branch

The Manitoba Growth, Enterprise & Trade – Petroleum Branch administers The Mines and Minerals Act and related regulations governing the exploration, development, production, transportation and storage of crude oil and natural gas.

M.D.

Municipal District

Major (full-blown) exercise

As described in CAN/CSA Z246.2-18, a multi-agency, multi-jurisdictional activity involving actual deployment of resources in a coordinated response, as if a real emergency had occurred. The full-scale exercise includes the mobilization of units, personnel, and equipment. Participants will assess plans and procedures and evaluate coordinated responses under crisis conditions.

Maximum Operating Pressure (MOP)

The maximum licensed operating pressure for a vessel or pipeline or a section of it.

Ministry of Energy and Resources (ER)

MER is the lead regulatory agency for the upstream petroleum industry in Saskatchewan.

Mobile air quality monitoring

Use of sophisticated portable equipment to track substances such as H₂S or SO₂ at very low parts per billion atmospheric concentrations.

Municipality

See local authority.

Municipal Emergency Operations Centre (MEOC)

The centre from which responsible municipal officials manage and support emergency operations within their jurisdiction, as well as formulate protective actions and provide public information. The centre has adequate workspace, maps, status boards, and communications capability.

Municipal Emergency Plan (MEP)

The emergency plan of the local authority.

Natural Gas Liquids (NGL)

These are hydrocarbons liquefied under pressure in field facilities or in gas processing plants. Natural gas liquids include ethane, propane, butane and pentanes plus and normally occur as a mixture of these compounds.

Physical Properties of NGL Products:

Colour - NGL products are colourless except when they include a condensate component, which gives them a light-yellow appearance. Releases during winter conditions can discolour snow. NGL products may appear as a white cloud when released to the atmosphere. This white cloud is formed by the condensing of moisture in the air.

Odour - Most NGL products have a mild petroleum odour. During pipeline transport NGL products are almost odourless.

Vapour Density - A measure of the mass per unit volume of the vapour (i.e. kg/m³). All NGL products transported by the company have a vapour density greater than air or a relative vapour density greater than 1.0.



Appendix F: ERP Reference Material, continued

Glossary of Terms, continued

NAV Canada

Canada's civil air navigation services provider, with operations coast to coast. NAV Canada provides air traffic control, flight information, weather briefings, aeronautical information services, airport advisory services, and electronic aids to navigation.

Notice to Airmen (NOTAM)

An order issued by Transport Canada restricting access to airspace in a defined area.

Notification

The distribution of project-specific information to participants that may be directly and adversely affected by the proposed energy development.

Odour complaint

A report that someone smells an offensive odour (may be sour gas) in the area.

Oil Spill Containment and Recovery Unit (OSCAR)

Trailer containing oil spill equipment for containment and recovery.

On-site command post (OSCP)

An emergency operations centre established in the immediate vicinity of the incident to provide immediate and direct response to the emergency and initially staffed by licensee personnel.

Partially controlled flow

A restricted flow of product at surface that cannot be shut off at the licensee's discretion with equipment on-site.

Personal consultation

Consultation through face-to-face visits or telephone conversations with all requisite individuals.

Petroleum industry

Refers to all petroleum industry operations.

Plume (gas plume)

An elongated mobile column of gas or smoke.

Protective Action Zone (PAZ)

An area downwind of a hazardous release where outdoor pollutant concentrations may result in life threatening or serious and possibly irreversible health effects on the public.

Protective Action Distance (PAD)

The distance from the incident to the EPZ outer boundary.

Provincial Operations Centre (POC)

An operations centre with the capacity to accommodate representatives from each government department.

Public

The group of people who may be or are impacted by an emergency (e.g., employees, contractors, neighbours, emergency response organizations, regulatory agencies, the media, appointed or elected officials, visitors, customers, etc., as appropriate).



Appendix F: ERP Reference Material, continued

Glossary of Terms, continued

Public facility (*Alberta specific*)

A public building, such as a hospital, rural school, or major recreational facility, situated outside of an urban centre that can accommodate more than 50 individuals and/or that requires additional transportation to be provided during an evacuation.

Public protection measures

The use of sheltering, evacuation, ignition, and isolation procedures to mitigate the impact of a hazardous release on members of the public.

Public Safety Group Supervisor

Member of the field response team. Individual charged with the responsibility of co-ordinating the evacuation or shelter of people in the emergency hazard Area. The Public Safety Group Supervisor reports to and may be located in the same location as the Incident Commander.

Publicly used development (*Alberta specific*)

Places where the presence of 50 individuals or less can be anticipated (e.g., places of business, cottages, campgrounds, churches, and other locations created for use by the non-resident public).

Publicly used facility (*British Columbia specific*)

Places where the presence of people can be anticipated. Examples include places of business, cottages, campgrounds, churches, and other locations created for use by the public. Includes any similar development the OGC may designate as a public facility.

Publicly used facility

Places where the presence of people can be anticipated. Examples include places of business, cottages, campground, churches, and other locations created for use by the public.

Reception centre

A centre established to register evacuees for emergency shelter, to assess their needs, and, if temporary shelter is not required because evacuees will stay elsewhere, to ascertain where they can be contacted.

Regional Emergency Operations Centre (REOC)

An operations centre established in a suitable location to manage the larger aspects of the emergency that is manned jointly by government and industry staff.

Residence

A dwelling that is occupied full time or part time.

Resident

Individual living in the area at a fixed location.

Resident data record

Form used to track the contact made with residents, businesses and transients.

Response zones (*Alberta specific*)

The Initial Isolation Zone (IIZ), Protective Action Zone (PAZ) and Emergency Planning Zone (EPZ).

Roadblock Crew

Personnel responsible for controlling access to the Emergency Hazard Area, reporting to the Public Safety Group Supervisor.



Appendix F: ERP Reference Material, continued

Glossary of Terms, continued

Rover

Member of the field response team. Individual responsible for assisting in the evacuation of the Hazard Area, reporting to the Public Safety Group Supervisor. May also be directed to shut-in / shut down equipment that may cause future safety hazards.

Rover Kit

A briefcase containing maps, forms, supplies and instructions needed by the Rover to carry out their duties.

S.A.B.A.

Supplied Air Breathing Apparatus.

S.C.B.A.

Self Contained Breathing Apparatus.

Serious injury

A serious injury includes the following:

- an injury that results in death;
- fracture of a major bone;
- amputation other than a portion of a finger or toe;
- loss of sight in an eye;
- internal haemorrhage;
- third degree burns;
- unconsciousness;
- An injury that results in paralysis (permanent loss of function).

Shelter-in-Place

Remaining indoors for short-term protection from exposure to toxic gas releases.

Sour gas

Natural gas, including solution gas, containing hydrogen sulphide (H₂S).

Sour gas release

An uncontrolled release of natural gas containing hydrogen sulphide (H₂S).

Sour multiphase product (*British Columbia specific*)

Any liquid that contains H₂S in the gas phase.

Sour multiphase pipeline (*British Columbia specific*)

A pipeline that transmits a multiphase product that contains more than 10 moles of H₂S per kilomole of natural gas in the gas phase.

Sour pipeline

Pipeline that conveys gas and/or liquid that contains sour gas.

Sour production facility

Facility that processes gas and/or liquid that contains sour gas

Sour well

An oil or gas well expected to encounter during drilling formations bearing sour gas or any oil or gas well capable of producing sour gas.



Appendix F: ERP Reference Material, continued

Glossary of Terms, continued

Special needs

Those persons for whom early response actions must be taken because they require evacuation assistance, requested early notification, do not have telephones, require transportation assistance, have a language or comprehension barrier, or have specific medical needs. Special needs also include those who decline to give information during the public consultation process and any residences or businesses where contact cannot be made.

Special sour well (*British Columbia specific*)

A designation that reflects the proposed well's proximity to populated centers and its maximum potential H₂S release rate during the drilling state. The casing or open-hole flow configuration is used in arriving at this designation.

Standing well

A well that has been drilled and cased but not perforated. A company is generally allowed to leave the well as standing for up to one year.

State of local emergency

A declaration by a local authority providing the necessary authority, resources, and procedures at the municipal level to allow an emergency to be resolved effectively and efficiently.

Sulphur dioxide (SO₂)

A colourless, water-soluble, suffocating gas formed by burning sulphur in air; also used in the manufacture of sulphuric acid. SO₂ has a pungent smell similar to a burning match. SO₂ is extremely toxic at higher concentrations. The molecular weight of SO₂ is heavier than air; however, typical releases are related to combustion, which makes the gaseous mixture lighter than air (buoyant).

Surface development

Dwellings that are occupied full-time or part-time, publicly used development, public facilities, including campgrounds and places of business, and any other surface development where the public may gather on a regular basis. Surface development includes residences immediately adjacent to the EPZ and those from which dwellers are required to egress through the EPZ.

Susceptible

The subpopulation of persons who may be considered more sensitive to the effects of H₂S and SO₂, including the elderly, pregnant women, and the very young, particularly preschool-aged children.

Tabletop exercise

As described in CAN/ CSA Z246.2-18, an informal exercise generally used to review resource allocations and roles and responsibilities of personnel and to familiarize new personnel with emergency operations without the stress and time constraints of a major exercise.

Technically complete Emergency Response Plan (ERP)

A plan that meets all applicable requirements.

Telephoners

Telephoners place calls to residents as directed by the Public Safety Group Supervisor.

Threatening telephone call

Any communication that threatens the well-being of company personnel or property. A form is provided in the manual to capture data from or about a person who calls with a threatening message.

Transient

An individual that is temporarily in the area (e.g. camper, cross-country skier).



Appendix F: ERP Reference Material, continued

Glossary of Terms, continued

Trapper

The holder of a provincial licensed and registered trapline for the purpose of hunting and trapping fur bearing animals.

Uncontrolled flow

A release of product that cannot be shut off at the licensee's discretion.

Urban centre

A city, town, village, summer village, or hamlet with no fewer than 50 separate buildings, each of which must be an occupied dwelling, or any similar development.

Unrestricted country development

Any collection of permanent dwellings situated outside of an urban centre and having more than eight permanent dwellings per quarter section.

Urban density development

Any incorporated urban centre, unincorporated rural subdivision, or group of subdivisions with no fewer than 50 separate buildings, each of which must be an occupied dwelling.

Vapour pressure

The pressure exerted by the vapour when the rate of evaporation is equal to the rate of condensation of the vapour. All NGL products have vapour pressure greater than atmospheric pressure air and therefore have to be kept under pressure or else they will vaporize.

Vapour-air plume / vapour cloud

When released to atmosphere, products form a vapour-air plume that is colourless, heavier than air and has a faint gasoline odour. Depending on the product released and the atmospheric conditions, water vapour may condense to form a cloud.

Water body

Natural or manmade; contains or conveys water continuously, intermittently, or seasonally. A natural water body is any location where water flows or is present, whether the flow or the presence of water is continuous, seasonal, intermittent, or occurs only during a flood. This includes, but is not limited to, the bed and shore of a river, stream, lake, creek, lagoon, swamp, marsh, slough, muskeg, or other natural drainage, such as ephemeral draws, wetlands, riparian areas, floodplains, fens, bogs, coulees, and rills. Examples of a manmade water body include, but are not limited to, a canal, drainage ditch, reservoir, dugout or other manmade surface feature.

Well servicing

The maintenance procedures performed on a producing or injecting well after the well has been completed and operations have commenced. Well servicing activities are generally conducted to maintain or enhance well productivity or injectivity.

Workover

The process of re-entering an existing well to perform remedial action that will restore or improve the productivity or injectivity of the target formation.

STEEL REEF INFRASTRUCTURE CORP. 24 HOUR 1-866-441-6203

24 HOUR EMERGENCY NUMBER: 1-866-441-6203

KEY RESPONSE PERSONNEL

For a detailed contact list, refer to the "Response Teams Phone List" yellow tab, behind the Section 2.0: Roles and Responsibilities blue tab.

OPERATIONS SUMMARY

Steel Reef operates a pipeline known as the "South Saskatchewan Access Pipeline" (SSAP). This pipeline transports natural gas produced near the town of Portal, ND to an existing gas processing facility owned and operated by Steel Reef near the community of North Portal, SK.

The portion of the pipeline in Canada is 3.0 km (3,182 ft), and the portion in the United States is 0.076 km (250 ft) in length. As this pipeline crosses between CAN/USA, these operations are regulated by the Canada Energy Regulator (CER) and the Federal Energy Regulatory Commission (FERC).

These operations are located in the Rural Municipality of Coalfields No. 4, and in Burke County, ND.

EPZ Information

The SSAP project has a maximum licensed H₂S concentration of 3% and a calculated Emergency Planning Zone (EPZ) of 1.56 km.

Closest Urban Centre

The Village of North Portal is approximately 4.1 km west of the EPZ, with a population of +/- 143.

Hydrology

There are no waterbodies identified within the SSAP EPZ.

Highways

There are no highways / rail impacted by the EPZ.

SAFETY EQUIPMENT

If any of the above mentioned safety equipment is insufficient, Steel Reef personnel will contact a local safety company who will be asked to provide additional equipment.

AREA USERS / TRANSIENTS

Note: All numbers, unless otherwise indicated, are 24 hours.

Hunters and Trappers (Wildlife Management Zone #31)

Recreational users use the areas within the EPZ and surrounding area on an intermittent basis primarily during hunting season (August - May). Please refer to <http://www.environment.gov.sk.ca/hunting> for up-to-date maps and hunting timetables.

SURFACE DEVELOPMENT INFORMATION

MEDIA STATEMENT

Refer all media inquiries to the Media Representative in Calgary,

However, if they insist on a statement, please use:

"We are currently dealing with the situation at hand to ensure the safety of the public, our personnel, and the environment. A statement will be released by the company once the facts have been determined. If you would like to leave your business card or phone number, a company representative will provide you with more information as it becomes available."

NOTE: See Section 3.0 Communication & Media for more information on media.

GOVERNMENT AGENCIES

Note: All numbers, unless otherwise indicated, are 24 hours.

CANADA FEDERAL AGENCIES

Canada Energy Regulator (CER) Pipeline Emergency: 819-997-7887
All other Emergencies: 403-299-2773
Online Reporting System <https://apps.cer-rec.gc.ca/ers>

Air Traffic Control
NAV Canada* 866-541-4102
Transport Canada** 877-992-6853

* If flight information or a NOTAM advisory is required, contact NAV Canada.
** If a NOTAM is required for airspace closure, contact the Transport Canada Aviation Operations Centre.

CANUTEC 888-226-8832
Environment & Climate Change Canada (ECCC)
Meteorological Services 780-951-8907
Department of Fisheries & Oceans Canada (DFO) 780-422-4505

US FEDERAL AGENCIES

National Response Center (NRC) 800-424-8802
Environmental Protection Agency (EPA) - Region 8 800-227-8917

Department of Transportation - Pipeline and Hazardous Materials Safety Administration (PHMSA) 800-467-4922

National Weather Service (NWS) Admin: 301-427-9855
Bismarck, ND Admin: 701-250-4224

Federal Aviation Administration (FAA)
Great Lakes Region 866-835-5322

Bureau of Land Management - Montana/Dakotas District
North Dakota Field Office Admin: 701-227-7700

SASKATCHEWAN AGENCIES

SK Ministry of Energy and Resources (ER) - Estevan 844-764-3637

Saskatchewan Ministry of Environment - Spill Report Centre 800-667-7525

R.M. of Coalfields No. 4 Admin: 306-388-2323

Saskatchewan Health Authority (SHA) / Ministry of Health 306-519-8570

Indigenous Service Canada (ISC) 306-780-6021
First Nations & Inuit Health (FNIH) Cell: 306-737-7497

Saskatchewan Public Safety Agency (SPSA) 800-667-9660

SaskPower - Electrical Safety 306-310-2220

Technical Safety Authority of Saskatchewan Admin: 866-530-8599

Saskatchewan Water Security Agency (WSA) 844-536-9494

Saskatchewan Ministry of Highways (MOH) 888-335-7623

Saskatchewan Labour Relations & Workplace Safety (OHS) 800-567-7233

Workers' Compensation Board (WCB) 800-667-7590

NORTH DAKOTA AGENCIES

North Dakota Industrial Commission (NDIC)

Oil & Gas Division 701-328-8020

ND Department of Environmental Quality (NDDEQ) Admin: 701-328-5150
Report a Spill 833-997-7455
Out-of-State 701-328-9921

North Dakota Department of Emergency Services (NDDES) 701-328-8100
For current Local Emergency Planning Committee contacts, refer to:
<https://www.des.nd.gov/countytribal-resources>

North Dakota Department of Mineral Resources - Oil & Gas Division Admin: 701-328-8036

North Dakota Highway Patrol - Northwest Region 701-328-2447
State Radio 701-328-9921

North Dakota Department of Transportation (NDDOT) 701-328-2500
Motor Carrier Permits (oversize/overweight)

North Dakota State Fire Marshal 701-328-5555

North Dakota Workforce Safety & Insurance (WSI) 800-777-5033

B

First District Health Unit - Burke County RHA Admin: 701-852-1376

SUPPORT SERVICES

Note: All numbers, unless otherwise indicated, are 24 hours.

Mobile Air Monitoring*
Diversified Oilfield Services - Virden, MB 204-851-1092
HSE Integrated - Red Deer, AB 888-346-8260
Firemaster Oilfield Services - Red Deer, AB 877-342-3473
Safety Boss - Edmonton, AB 800-882-4967

* Dispatch support services at a Level 1 Emergency. Response time is expected to be approximately 2-3 hours from Virden, MB and 12-15 hours from Red Deer, AB.

Oilfield Fire Fighting / Safety Contractors
HSE Integrated Ltd. - Weyburn 888-346-8260
Diversified Oilfield Services - Virden, MB 204-851-1092
Carson's Safety Services - Lampman Admin: 306-487-4127
Firemaster Oilfield Services Inc. - Red Deer, AB 877-342-3473

Well Control Specialists
Capstone Blowout Recovery - Red Deer, AB 866-347-3911
International Well Control Inc. - Red Deer, AB 833-828-4892

Ignition Services
International Well Control Inc. - Red Deer, AB 833-828-4892
Capstone Blowout Recovery - Red Deer, AB 866-347-3911

Electrical and Instrumentation
PTW Energy Services - Estevan 306-634-5617
Estevan Meter Services Ltd. - Estevan 306-634-5304

Crane Services
Skylift Services - Estevan 306-634-5555
Bert Baxter Transport - Estevan 306-634-3616

Hydrovac Services
Steam-Est Industries Ltd. - Estevan 306-634-3144
Courage Oilfield Services Ltd. - Oxbow 306-483-2130

Bus Transportation
Engelheim Charter Inc. - Emerald Park 800-667-7433
South Sask Bus Lines - Moose Jaw 306-774-9883

Helicopter Companies
Heli-Lift International Inc. - Yorkton 306-783-5438
Heli Source Ltd. - Regina 855-876-5716

Emergency Response Management
H₂Safety Services Inc. - Calgary 403-212-2332
Toll Free 888-216-2332

Spill Response
Matrix Solutions Inc. - Swift Current, SK 877-774-5525
Clean Harbors - Regina, SK 800-645-8265
Haztech - Regina, SK 866-919-9114

Air Traffic Control
NAV Canada* 866-541-4102
Transport Canada** 877-992-6853

* If flight information or a NOTAM advisory is required, contact NAV Canada
** If a NOTAM is required for airspace closure, contact the Transport Canada Aviation Operations Centre

Emergency Response Assistance Canada (ERAC) 800-265-0212

Oil Spill Contingency Group (OSCG) - Area 4 & 5 306-634-6277

* see website for more information (<http://saskoilspill.com/>)

EMERGENCY SERVICES

Note: All numbers, unless otherwise indicated, are 24 hours.

RCMP / Fire / Ambulance 911
STARS Air Ambulance 888-888-4567

Hospitals
St. Joseph's Hospital - Estevan 306-637-2400
Galloway Health Centre - Oxbow 306-483-2956
Weyburn General Hospital 306-842-8400

Saskatchewan Poison Control 306-454-1212

Reception Centres
North Portal Community Hall 306-927-5050
302 Belfast Street, North Portal, SK

Royal Canadian Legion Admin: 306-634-3135
1317 4 Street, Estevan, SK

Carnduff Education Complex Admin: 306-482-3491
506 Anderson Avenue, Carnduff, SK





South SK Access Pipeline - Sour Gas Pipelines

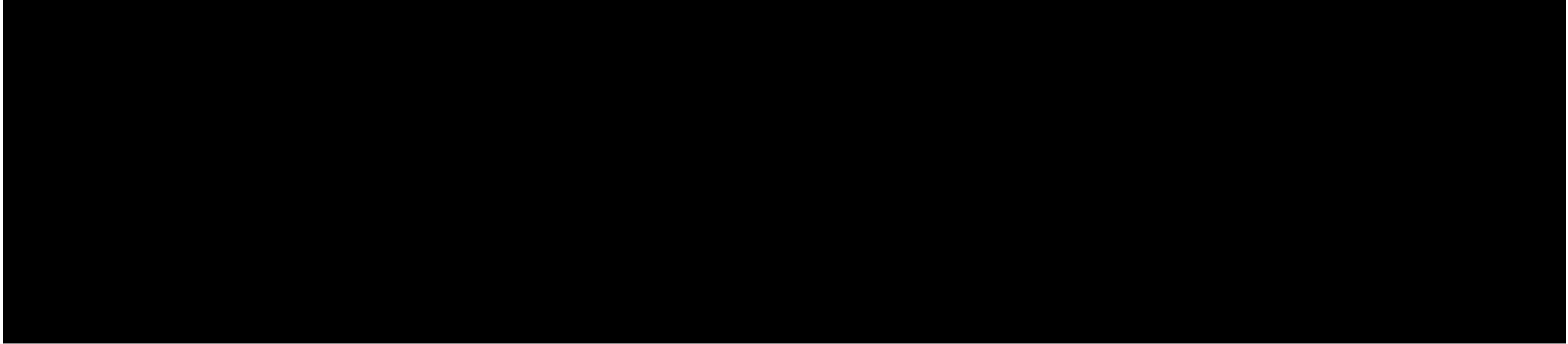



South SK Access Pipeline (SSAP) CER Regulated Pipelines

Emergency Contact Information

<p>For Emergencies involving inter-provincial pipelines, the Canada Energy Regulator is the primary management agency – they will be contacted by the Transportation Safety Board.</p> <p>**A pipeline is CER-regulated due to the fact that it crosses a provincial or federal border. **</p>		
<p>This must be your first call</p>		
<p>Transportation Safety Board (TSB) – for pipeline incidents</p>	24 Hr Incident Line	819-997-7887
	Facsimile	819-953-7876
	Email	PipelineNotifications@tsb.gc.ca
<p>Call the TSB 24 Hr Incident Line when an incident meets the Immediately Reportable Events (see page 2 for criteria) for all Canada Energy Regulator (CER) regulated pipelines and facilities.</p> <p style="text-align: center;">Both the phone notification and the input of information into the CER’s Online Event Reporting System (OERS): https://apps.cer-rec.gc.ca/ers/home/index are required to occur as soon as possible and no later than three hours of the incident being discovered. For all other events (non-immediate) companies are only required to input the information via the OERS.</p>		
<p>Secondary Calls</p> <p>Contact as needed AFTER contacting the TSB and CER.</p>		
<p>SK Ministry of Energy & Resources (ER)</p>	24 Hr	844-764-3637
<p>North Dakota Industrial Commission (NDIC)</p>	24 Hr	701-328-8020
<p>Hazardous occurrences (under Part XVI of the Canada Oil and Gas Occupational Safety and Health Regulations) and incidents requiring medical evacuations are to be reported to the CER immediately.</p>		
	<p>Canada Energy Regulator</p>	<p>Régie de l’énergie du Canada</p>



Definition of an Emergency

CAN /CSA Z246.2-18 defines an emergency as “an event or imminent event, outside of the scope of normal operations that requires prompt coordination of resources to protect people, the environment, and property”.

Emergencies can result from numerous causes including pipeline and equipment failure, human error and natural perils such as tornadoes, hurricanes, floods, or earthquakes and terrorism or other criminal activities. Multi-hazard emergencies such as an earthquake causing pipeline breaks, fires and explosions, which result in injury and further property damage, can also occur.

Companies must consider all probable emergencies and have applicable procedures in place to deal with potential effects and threats to people, property and the environment, as determined through a formal hazard assessment.

CER Immediately Reportable Events (Significant Incident)

Section 52 of the Onshore Pipeline Regulations (OPR) requires companies to notify the CER of all incidents relating to the construction, operation, or abandonment of their pipelines.

A significant incident is an acute event that results in:

1. death;
2. missing person (as reportable pursuant to the *Canada Oil and Gas Drilling and Production Regulations (DPR)* under the *Canada Oil and Gas Operations Act (COGOA)* or the *Oil and Gas Operations Act (OGOA)*);
3. a serious injury (as defined in the OPR or TSB regulations);
4. a fire or explosion that causes a pipeline or facility to be inoperative;
5. a LVP hydrocarbon release in excess of 1.5m³ that leaves company property or the right of way;
6. a rupture; or
7. a toxic plume as defined in CSA Z662.

Note: A “rupture” is an instantaneous release that immediately impairs the operation of a pipeline segment such that the pressure of the segment cannot be maintained.

Companies are required to report a death or serious injury to a person only where the death or injury is a result of an occurrence that relates to the construction, operation, or abandonment of a “pipeline”. Whether a death or injury is related to the construction, operation, or abandonment of a pipeline will depend on whether the person who was killed or injured was working at the time of the incident and/or whether the work was a cause or contributing factor to the incident. It is important to note that, unlike the Canada Labour Code (CLC), the OPR does not differentiate between different types of “persons”. Therefore, companies must report all deaths or serious injuries to any person that occur relating to pipeline construction, operation, or abandonment regardless of whether or not that person was directly employed by the company.

The definition of “serious injury” in the OPR is not exhaustive and contains multiple injuries that qualify as serious, including “the fracture of a major bone”. The CER uses the following definition of “major bone”: skull, mandible, spine, scapula, pelvis, femur, humerus, fibula, tibia, radius, and ulna.

TSB Immediately Reportable Events

Call the TSB as soon as possible after discovery of any of the following occurrences:

- An occurrence that results in;
 - a death;
 - a serious injury (as defined in the OPR or TSB regulations);
 - an unintended or uncontrolled LVP hydrocarbon release in excess of 1.5 m³ that leaves company property or occurs on or off the right of way;
 - an unintended or uncontrolled sweet natural gas or HVP release >30,000 m³;



- any unintended or uncontrolled release of sour natural gas or hydrogen sulfide;
- a significant adverse effect on the environment (a release of any chemical or physical substance at a concentration or volume sufficient to cause an irreversible, long-term, or continuous change to the ambient environment in a manner that causes harm to human life, wildlife, or vegetation)
- a fire, ignition, or explosion that poses a threat to the safety of any person, property, or the environment.
- A rupture:
 - an instantaneous release that immediately impacts the operation of a pipeline segment such that the pressure of the segment cannot be maintained.
- A Toxic Plume:
 - a band of service fluid or other contaminant (e.g. hydrogen sulfide or smoke) resulting from an incident that causes people, including employees, to take protective measures (e.g. muster, shelter-in-place or evacuation).

Where an event meets any of the above definitions, companies are required to notify the TSB Reporting Hotline at (819) 997-7887. Subsequently, the company is required to input the details required by both the TSB (see TSB regulations) and the CER into the OERS. The phone notification and the input of information into OERS are required to occur as soon as possible and no later than three hours of the incident being discovered. The goal of the initial phone notification is to allow the relevant agencies to mobilize a response to an incident, if required. Note that OERS will automatically determine whether the event meets the definition of an “Incident that Harms People or the Environment”, however the company will be responsible for specifically indicating whether the incident meets the definitions of “Rupture” and “Toxic Plume”.

For all other events that do not meet any of the definitions in this section, companies are not required to phone the TSB Reporting Hotline but must report the event as soon as possible and no later than twenty-four hours after the event was discovered.

Multiple Incident Types

It is possible that a single occurrence may result in multiple incident types. If multiple incident types occur as a result of a single occurrence, companies are expected to report those incident types under a single incident report.

Examples of situations where this might be the case include but are not limited to:

- A pipeline rupture (occurrence) where there is a release of gas (incident type) and an explosion (incident type);
- An industrial accident (occurrence) that causes a death (incident type), a serious injury (incident type) and a fire (incident type);
- An operational malfunction (occurrence) that causes an overpressure (incident type) and a release of product (incident type); or
- An operational malfunction (occurrence) that causes several concurrent or immediately consecutive overpressures (incident types).

In cases where an incident has occurred, and a second incident occurs during the response to the initial incident (e.g. a fire occurs during the clean-up of a spill), the second incident is considered distinct and should be reported separately.

The events that are reportable using the online reporting system are:

- incidents under the OPR, PPR, and DPR/*Oil and Gas Drilling Regulations*;
- emergency burning or flaring under the PPR;
- hazard identification under the PPR;
- suspension of operations under the PPR;
- near-misses under the DPR;



- serious accidents or incidents under the *Canada Oil and Gas Geophysical Operations Regulations/Oil and Gas Geophysical Operations Regulations*;
- emergencies or accidents under the *Canada Oil and Gas Installation Regulations/Oil and Gas Installation Regulations*; and
- accidents, illnesses, and incidents under the *Canada Oil and Gas Diving Regulations/Oil and Gas Diving Regulations*.

In the event that OERS is unavailable, companies are directed to report events to the TSB Reporting Hotline at 819-997-7887.

Reporting Timelines

Section 52 of the OPR requires companies to immediately notify the CER of any incident. Section 52 of the OPR also requires the submission of a Preliminary Incident Report (PIR) and a Detailed Incident Report (DIR) “as soon as is practicable”. Generally, companies’ initial notification of an incident will satisfy the PIR requirements. The information required for a DIR must be submitted within 12 weeks of reporting an incident. For complex incidents, companies may request an extension for submission of a DIR.

The CER and the TSB have adopted a single window reporting approach. However, in some areas, the TSB reporting requirements are somewhat different than the CER requirements. For additional details on the TSB reporting requirements, companies should refer to the TSB website (<http://www.bst-tsb.gc.ca/eng/incidents-occurrence/index.asp>).

Transportation Safety Board of Canada
Place du centre, 4th Floor
200 Promenade du Portage
Hull, Quebec K1A 1K8
Facsimile 819-953-7876

Supporting Information

The table below indicates the location of CER supporting documentation in this emergency response plan.

Supporting Information	Found in
CER Distribution	Foreword: Distribution List Page 3
Company 24/7 Emergency Number	Area Specific Information: Binder Cover
Area Map of CER Regulated Facilities	Area Specific Information
TSB Roles & Responsibilities	Section 5: External Agencies Federal Roles Chart
CER Roles & Responsibilities	Section 5: External Agencies Federal Roles Chart
Safety data sheets (SDS)	Area Specific Information
Health and Safety Plan	Please refer to the company's Health & Safety Plan located at the corporate head office.



Emergency Preparedness & Response Policy

Emergency Management Expectations

An effective emergency management program includes being prepared for emergencies, responding in the event of an emergency and ensuring that operations are able to continue safely and can recover in a timely, efficient manner.

Emergency management is critical to ensuring that people, the environment, the public, the organization's assets and reputation are protected in the event of an unanticipated hazard event, be it natural, technological or human-induced.

Emergency Management Preparedness

Emergency preparedness is a continuous process of all-hazards planning and coordination in order to effectively minimize the adverse effects and consequences inherent in any emergency incident. Through the use of such tools as exercises, proactive resource management and capability analysis, preparedness is one of the key pillars with which to ensure the adaptation of comprehensive approaches for the company's emergency management strategy. The emergency management process must include the following:

- Hazard Risk and Vulnerability Assessment
- Public Involvement
- Communications Planning
- Situational Awareness
- Crisis Management Plans
- Emergency Response Plans
- Emergency Management Resources
- Competence, Training and Awareness
- Exercises and Drills
- Record Keeping
- Distributions Lists (Internal and External)
- Continuous Improvement

Emergency Response Plans should contain:

- Communication procedures
- Emergency contacts
- Evacuation and Rescue plans
- Equipment locations and supply companies
- Spill response and containment (where required)
- Meet regulatory requirements
- Event classification
- Activation and Stand Down Levels
- Guidelines for medical emergencies
- Defined roles and responsibilities
- Maps and Emergency Planning Zones
- Mutual Aid Understandings (where applicable)

Confidential ERPs will be available at the field Incident Command Post and the Corporate Emergency Response Centre.



Extended Emergencies

In an extended emergency, company responders will develop an Incident Action Plan utilizing forms found within ERP, which may include:

- ICS Form 201 – Incident Briefing
- ICS Form 202 – Incident Objectives
- Form A1 – Initial Emergency Report
- Form A4 – Incident Action Plan (IAP) Checklist

Emergency Response, Continuity and Recovery

In the event of an emergency, each business unit shall determine the level of emergency as per established protocols and respond according to their respective emergency response plans. Response includes the mobilization and ongoing management of resources, people, equipment and assets to manage the effects of an incident; functions inclusive of the Incident Command System (ICS), the company's primary response platform.

Each business unit shall establish, implement and maintain procedures for communicating information related to emergency management, including:

- Communication of plans and procedures to employees, operating partners, contractors, the supply chain, regulators and local communities; and
- Emergency and crisis communications to stakeholders, including emergency responders, regulators, the media, family members and the public.

Emergency Management Monitoring, Assessment and Continuous Improvement

Lessons learned and knowledge generated from monitoring results should be used to develop "improved practices", which are then shared widely. After emergencies or disasters occur, a systematic approach is used to learn lessons from the experience, increase effectiveness and improve emergency management practices and processes.

Manual Updating Procedures and Schedule

The company's Corporate and Site-Specific ERPs are to be updated annually and submitted to the CER on or before April 1st of each year, or when significant changes (either operational or identified from exercises/incidents and resulting debriefs) occur or are identified. If an update occurs outside of the January 1st to April 1st period, a letter must be submitted to the CER indicating that there have been no changes to operations since the ERP was last submitted. ERP updates are performed by a third-party company (H2Safety), whose expertise in the field provides company personnel with the education, training, and resources to excel in Emergency Response. Approvals for ERP updates will be carried out by the company's Emergency Management Coordinator.



Debriefing

Internal Debriefing

The Incident Commander, in consultation with the Lead Agency and/or other regulatory body, will order "Return to Normal" status.

- All response team members and on-site personnel, including contract personnel and emergency services, will be notified.
- All previous contacts including public, workers, landowners, government and industrial operators must also be notified of the end of the emergency.
- Ensure a media statement is prepared and delivered by Senior Management.
- Debriefing meeting(s) with company personnel (including insurance, legal, and human resources as appropriate) must be conducted.
- Debriefing meeting(s) to review effectiveness of the Emergency Response Plan must be conducted. Feedback and comments as a result of the debrief must be incorporated into the ERP revision and procedures. This feedback should be submitted to the ERP provider.
- Debriefing meeting(s) with residents, landowners, Lead Agency and other government agencies and all other impacted parties may be conducted.
- Document all "Return to Normal" activities.
- Complete response debriefing for all response teams. Submit, in writing, response findings and recommendations to the Incident Commander when applicable, which will be submitted to the overall report writer.

Public Debriefing

When the public has been impacted, company operations should provide the public information as soon after the emergency as possible, to answer any questions or concerns. This should be done by a senior company representative, a trained Media Advisor, or by the Incident Commander.

After an emergency, a number of additional items should be considered:

- Debriefings, as mentioned above.
- Crisis management for company personnel and for other members of the public that may have been significantly affected by the emergency.
- If the emergency is of a level where it has impacted the public, an information center may be established within the community where the emergency occurred to answer any questions posed by the public.
- Establish a means of compensating citizens who may have had out-of-pocket expenses (such as meals and lodging costs) as a result of the emergency.
- Through the media, provide details of the investigation into the incident that are pertinent to the public, as it becomes available.

Health and Safety Plan

The company's extensive Health and Safety program is to be implemented at all times during and after an incident. Training is provided to all company employees and contractors; all information and documentation can be found in the Health and Safety Manual.

Site Specific Control Points and Response

In the event of an incident (reported from an external source and/or confirmed by a drop in pressure), an operator would be sent out to visually confirm the need to shut down operations. Operators have the ability to manually trip the ESDs at the risers on the CER line. The operator would then immediately contact his/her supervisor and the TSB, and then work with internal support and outside agencies to determine a plan of action for resolving the source of the release.

STEEL REEF INFRASTRUCTURE CORP. 24 HOUR 1-866-441-6203

24 HOUR EMERGENCY NUMBER: 1-866-441-6203

KEY RESPONSE PERSONNEL

For a detailed contact list, refer to the "Response Teams Phone List" yellow tab, behind the Section 2.0: Roles and Responsibilities blue tab.

OPERATIONS SUMMARY

Steel Reef operates a pipeline known as the Sinclair CER Regulated pipeline. This pipeline transports natural gas from oil batteries in the Sinclair area of Manitoba to an existing gas processing facility owned and operated by Steel Reef near Nottingham, SK. These operations are located in the Saskatchewan Rural Municipalities of Storthoaks No. 31 and Antler No. 61 and the Manitoba Rural Municipality of Pipestone.

EPZ Information

The Sinclair pipeline has a maximum licensed H₂S concentration of 2% and a calculated Emergency Planning Zone (EPZ) of 460m.

Closest Urban District

The community of Reston, MB is located approximately 23.4 km west of the EPZ, with a population of +/- 569.

Hydrology

Jackson Creek, Graham Creek and numerous unnamed waterbodies identified within the Sinclair EPZ.

Highways

Highway 2 and Highway 13.

SAFETY EQUIPMENT

If any of the above mentioned safety equipment is insufficient, Steel Reef personnel will contact a local safety company who will be asked to provide additional equipment.

AREA USERS / TRANSIENTS

Note: All numbers, unless otherwise indicated, are 24 hours.

Users and Tappers

Recreational users use the areas within the EPZ and surrounding area on an intermittent basis primarily during hunting season (August - May). Please refer to <http://www.environment.gov.sk.ca/hunting> for up-to-date maps and hunting timetables.

SURFACE DEVELOPMENT INFORMATION

Note: Detailed surface development information can be found behind the white "Confidential Information" tab. Additionally, procedures for contacting and evacuating / sheltering affected parties, as well as procedures for isolating the EPZ, can be found in "Section 4: Emergency Response Procedures".

MEDIA STATEMENT

Refer all media inquiries to the Media Representative in Calgary, [REDACTED].
However, if they insist on a statement, please use:

"We are currently dealing with the situation at hand to ensure the safety of the public, our personnel, and the environment. A statement will be released by the company once the facts have been determined. If you would like to leave your business card or phone number, a company representative will provide you with more information as it becomes available."

NOTE: See Section 3.0 Communication & Media for more information on media.

GOVERNMENT AGENCIES

Note: All numbers, unless otherwise indicated, are 24 hours.

FEDERAL AGENCIES

Canada Energy Regulator (CER) Pipeline Emergency: 819-997-7887
All other Emergencies: 403-299-2773
Online Reporting System <https://apps.cer-rec.gc.ca/ers>

Air Traffic Control
NAV Canada* 866-541-4102
Transport Canada** 877-992-6853

* If flight information or a NOTAM advisory is required, contact NAV Canada.
** If a NOTAM is required for airspace closure, contact the Transport Canada Aviation Operations Centre.

CANUTEC 888-226-8832

Environment & Climate Change Canada (ECCC)
Meteorological Services 780-951-8907

Department of Fisheries & Oceans Canada (DFO) 780-422-4505

SASKATCHEWAN AGENCIES

SK Ministry of Energy and Resources (ER) - Estevan 844-764-3637

Saskatchewan Ministry of Environment - Spill Report Centre 800-667-7525

R.M. of Storthoaks No. 31 Admin: 306-449-2262

R.M. of Antler No. 61 Admin: 306-452-3263

Saskatchewan Health Authority (SHA) / Ministry of Health 306-519-8570

Indigenous Service Canada (ISC) 306-780-6021

Saskatchewan Public Safety Agency (SPSA) 306-787-9563

SaskPower - Electrical Safety 306-310-2220

Technical Safety Authority of Saskatchewan (TSAS) Admin: 866-530-8599

Saskatchewan Water Security Agency (WSA) 844-536-9494

Saskatchewan Ministry of Highways (MOH) 888-335-7623

Saskatchewan Labour Relations & Workplace Safety (OHS) 800-567-7233

Workers' Compensation Board (WCB) 800-667-7590

MANITOBA AGENCIES

Manitoba Economic Development, Investment & Trade 204-748-4260
Resource Development (Petroleum) 800-223-5215

R.M. of Pipestone Admin: 204-877-3327

Prairie Mountain Health (Manitoba) Admin: 204-724-8285

Emergency Management Organization (EMO) 204-945-5555

Inspection and Technical Services Branch (Boilers/Electrical) 888-389-3473

Manitoba Environment, Climate and Parks (TDG) 855-944-4888

Manitoba Transportation and Infrastructure
Brandon Office Admin: 204-726-6800

Manitoba Workplace Safety & Health (WS&H) 855-957-7233

SUPPORT SERVICES

Note: All numbers, unless otherwise indicated, are 24 hours.

Mobile Air Monitoring*

Diversified Oilfield Services - Virden, MB 204-851-1092
HSE Integrated - Red Deer, AB 888-346-8260
Firemaster Oilfield Services - Red Deer, AB 877-342-3473
Safety Boss - Edmonton, AB 800-882-4967

* Dispatch support services at a Level 1 Emergency. Response time is expected to be approximately 2-3 hours from Virden, MB and 12-15 hours from Red Deer, AB.

Oilfield Fire Fighting / Safety Contractors

HSE Integrated Ltd. - Weyburn 888-346-8260
Diversified Oilfield Services - Virden, MB 204-851-1092
Carson's Safety Services - Lampman Admin: 306-487-4127
Firemaster Oilfield Services Inc. - Grande Prairie, AB 877-342-3473

Well Control Specialists

Capstone Blowout Recovery - Red Deer, AB 866-347-3911
International Well Control Inc. - Red Deer, AB 833-828-4892

Ignition Services

International Well Control Inc. - Red Deer, AB 833-828-4892
Capstone Blowout Recovery - Red Deer, AB 866-347-3911

Electrical and Instrumentation

PTW Energy Services - Estevan 306-634-5617
Estevan Meter Services Ltd. - Estevan 306-634-5304

Hydrovac Services

Steam-Est Industries Ltd. - Estevan 306-634-3144
Courage Oilfield Services Ltd. - Oxbow 306-483-2130

Bus Transportation

Engelheim Charter Inc. - Emerald Park 800-667-7433
South Sask Bus Lines - Moose Jaw 306-774-9883

Helicopter Companies

Heli-Lift International Inc. - Yorkton 306-783-5438
Heli Source Ltd. - Regina 855-876-5716

Emergency Response Management

H₂Safety Services Inc. - Calgary 403-212-2332
Toll Free 888-216-2332

Spill Response

Matrix Solutions Inc. - Swift Current, SK 877-774-5525
Clean Harbors - Regina, SK 800-645-8265
Haztech - Regina, SK 866-919-9114

Emergency Response Assistance Canada (ERAC)

800-265-0212

EMERGENCY SERVICES

Note: All numbers, unless otherwise indicated, are 24 hours.

RCMP / Fire / Ambulance 911
STARS Air Ambulance 888-888-4567

Hospitals

Virden Health Centre 204-748-1230
Galloway Health Centre - Oxbow 306-483-2956
Southeast Integrated Care Centre - Moosomin 306-435-3303
Weyburn General Hospital 306-842-8400

Saskatchewan Poison Control

306-454-1212

Reception Centre

Carnduff Education Complex Admin: 306-482-3491
506 Anderson Avenue, Carnduff, SK
Rest'n Inn Admin: 204-877-3383
307 - 6th Avenue W, Reston, MB
Comfort Inn & Suites Admin: 204-707-6020
380 Frontage Rd, Virden, MB



SINCLAIR CER PIPELINE



Draft Date: September 14, 2022 ET	Scale: 1:60,000	Map: 13665
-----------------------------------	-----------------	------------

Revision Date: July 11, 2024 ET	UTM ZONE 13 NAD83
---------------------------------	-------------------



MAP PRODUCED BY



Sinclair - Sour Gas Pipeline

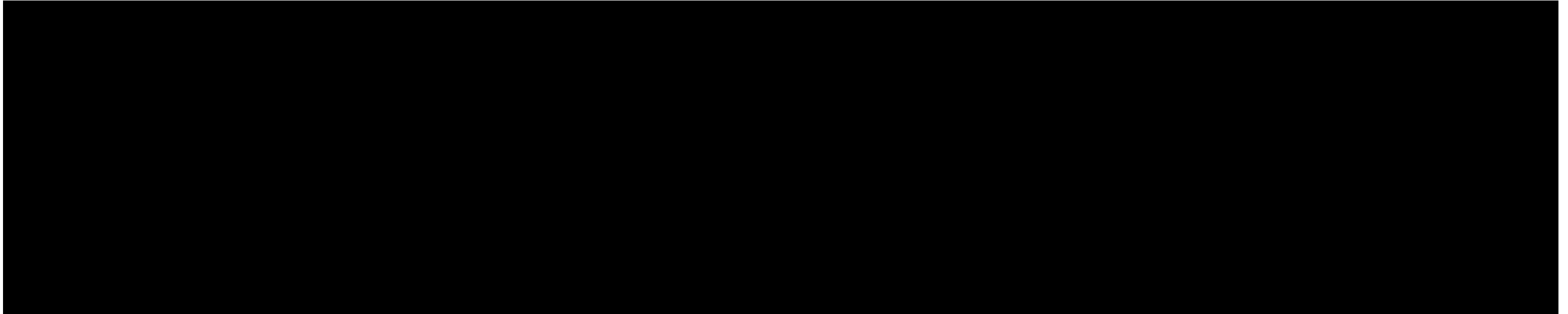



Sinclair CER Regulated Pipeline

Emergency Contact Information

<p>For Emergencies involving inter-provincial pipelines, the Canada Energy Regulator is the primary management agency – they will be contacted by the Transportation Safety Board.</p> <p>**A pipeline is CER-regulated due to the fact that it crosses a provincial or federal border. **</p>		
<p>This must be your first call</p>		
<p>Transportation Safety Board (TSB) – for pipeline incidents</p>	<p>24 Hr Incident Line</p>	<p>819-997-7887</p>
	<p>Facsimile</p>	<p>819-953-7876</p>
	<p>Email</p>	<p>PipelineNotifications@tsb.gc.ca</p>
<p>Call the TSB 24 Hr Incident Line when an incident meets the Immediately Reportable Events (see page 2 for criteria) for all Canada Energy Regulator (CER) regulated pipelines and facilities.</p> <p>Both the phone notification and the input of information into the CER’s Online Event Reporting System (OERS): https://apps.cer-rec.gc.ca/ers/home/index are required to occur as soon as possible and no later than three hours of the incident being discovered. For all other events (non-immediate) companies are only required to input the information via the OERS.</p>		
<p>Secondary Calls</p> <p>Contact as needed AFTER contacting the TSB and CER.</p>		
<p>SK Ministry of Energy & Resources (ER)</p>	<p>24 Hr</p>	<p>844-764-3637</p>
<p>MB Natural Resources & Northern Development (MNRND)</p>	<p>24 Hr</p>	<p>800-223-5215</p>
<p>Hazardous occurrences (under Part XVI of the Canada Oil and Gas Occupational Safety and Health Regulations) and incidents requiring medical evacuations are to be reported to the CER immediately.</p>		
	<p>Canada Energy Regulator</p>	<p>Régie de l’énergie du Canada</p>



Definition of an Emergency

CAN /CSA Z246.2-18 defines an emergency as “an event or imminent event, outside of the scope of normal operations that requires prompt coordination of resources to protect people, the environment, and property”.

Emergencies can result from numerous causes including pipeline and equipment failure, human error and natural perils such as tornadoes, hurricanes, floods, or earthquakes and terrorism or other criminal activities. Multi-hazard emergencies such as an earthquake causing pipeline breaks, fires and explosions, which result in injury and further property damage, can also occur.

Companies must consider all probable emergencies and have applicable procedures in place to deal with potential effects and threats to people, property and the environment, as determined through a formal hazard assessment.

CER Immediately Reportable Events (Significant Incident)

Section 52 of the Onshore Pipeline Regulations (OPR) requires companies to notify the CER of all incidents relating to the construction, operation, or abandonment of their pipelines.

A significant incident is an acute event that results in:

1. death;
2. missing person (as reportable pursuant to the *Canada Oil and Gas Drilling and Production Regulations (DPR)* under the *Canada Oil and Gas Operations Act (COGOA)* or the *Oil and Gas Operations Act (OGOA)*);
3. a serious injury (as defined in the OPR or TSB regulations);
4. a fire or explosion that causes a pipeline or facility to be inoperative;
5. a LVP hydrocarbon release in excess of 1.5m³ that leaves company property or the right of way;
6. a rupture; or
7. a toxic plume as defined in CSA Z662.

Note: A “rupture” is an instantaneous release that immediately impairs the operation of a pipeline segment such that the pressure of the segment cannot be maintained.

Companies are required to report a death or serious injury to a person only where the death or injury is a result of an occurrence that relates to the construction, operation, or abandonment of a “pipeline”. Whether a death or injury is related to the construction, operation, or abandonment of a pipeline will depend on whether the person who was killed or injured was working at the time of the incident and/or whether the work was a cause or contributing factor to the incident. It is important to note that, unlike the Canada Labour Code (CLC), the OPR does not differentiate between different types of “persons”. Therefore, companies must report all deaths or serious injuries to any person that occur relating to pipeline construction, operation, or abandonment regardless of whether or not that person was directly employed by the company.

The definition of “serious injury” in the OPR is not exhaustive and contains multiple injuries that qualify as serious, including “the fracture of a major bone”. The CER uses the following definition of “major bone”: skull, mandible, spine, scapula, pelvis, femur, humerus, fibula, tibia, radius, and ulna.

TSB Immediately Reportable Events

Call the TSB as soon as possible after discovery of any of the following occurrences:

- An occurrence that results in;
 - a death;
 - a serious injury (as defined in the OPR or TSB regulations);
 - an unintended or uncontrolled LVP hydrocarbon release in excess of 1.5 m³ that leaves company property or occurs on or off the right of way;
 - an unintended or uncontrolled sweet natural gas or HVP release >30,000 m³;



- any unintended or uncontrolled release of sour natural gas or hydrogen sulfide;
- a significant adverse effect on the environment (a release of any chemical or physical substance at a concentration or volume sufficient to cause an irreversible, long-term, or continuous change to the ambient environment in a manner that causes harm to human life, wildlife, or vegetation)
- a fire, ignition, or explosion that poses a threat to the safety of any person, property, or the environment.
- A rupture:
 - an instantaneous release that immediately impacts the operation of a pipeline segment such that the pressure of the segment cannot be maintained.
- A Toxic Plume:
 - a band of service fluid or other contaminant (e.g. hydrogen sulfide or smoke) resulting from an incident that causes people, including employees, to take protective measures (e.g. muster, shelter-in-place or evacuation).

Where an event meets any of the above definitions, companies are required to notify the TSB Reporting Hotline at (819) 997-7887. Subsequently, the company is required to input the details required by both the TSB (see TSB regulations) and the CER into the OERS. The phone notification and the input of information into OERS are required to occur as soon as possible and no later than three hours of the incident being discovered. The goal of the initial phone notification is to allow the relevant agencies to mobilize a response to an incident, if required. Note that OERS will automatically determine whether the event meets the definition of an “Incident that Harms People or the Environment”, however the company will be responsible for specifically indicating whether the incident meets the definitions of “Rupture” and “Toxic Plume”.

For all other events that do not meet any of the definitions in this section, companies are not required to phone the TSB Reporting Hotline but must report the event as soon as possible and no later than twenty-four hours after the event was discovered.

Multiple Incident Types

It is possible that a single occurrence may result in multiple incident types. If multiple incident types occur as a result of a single occurrence, companies are expected to report those incident types under a single incident report.

Examples of situations where this might be the case include but are not limited to:

- A pipeline rupture (occurrence) where there is a release of gas (incident type) and an explosion (incident type);
- An industrial accident (occurrence) that causes a death (incident type), a serious injury (incident type) and a fire (incident type);
- An operational malfunction (occurrence) that causes an overpressure (incident type) and a release of product (incident type); or
- An operational malfunction (occurrence) that causes several concurrent or immediately consecutive overpressures (incident types).

In cases where an incident has occurred, and a second incident occurs during the response to the initial incident (e.g. a fire occurs during the clean-up of a spill), the second incident is considered distinct and should be reported separately.

The events that are reportable using the online reporting system are:

- incidents under the OPR, PPR, and DPR/*Oil and Gas Drilling Regulations*;
- emergency burning or flaring under the PPR;
- hazard identification under the PPR;
- suspension of operations under the PPR;
- near-misses under the DPR;



- serious accidents or incidents under the *Canada Oil and Gas Geophysical Operations Regulations/Oil and Gas Geophysical Operations Regulations*;
- emergencies or accidents under the *Canada Oil and Gas Installation Regulations/Oil and Gas Installation Regulations*; and
- accidents, illnesses, and incidents under the *Canada Oil and Gas Diving Regulations/Oil and Gas Diving Regulations*.

In the event that OERS is unavailable, companies are directed to report events to the TSB Reporting Hotline at 819-997-7887.

Reporting Timelines

Section 52 of the OPR requires companies to immediately notify the CER of any incident. Section 52 of the OPR also requires the submission of a Preliminary Incident Report (PIR) and a Detailed Incident Report (DIR) “as soon as is practicable”. Generally, companies’ initial notification of an incident will satisfy the PIR requirements. The information required for a DIR must be submitted within 12 weeks of reporting an incident. For complex incidents, companies may request an extension for submission of a DIR.

The CER and the TSB have adopted a single window reporting approach. However, in some areas, the TSB reporting requirements are somewhat different than the CER requirements. For additional details on the TSB reporting requirements, companies should refer to the TSB website (<http://www.bst-tsb.gc.ca/eng/incidents-occurrence/index.asp>).

Transportation Safety Board of Canada
Place du centre, 4th Floor
200 Promenade du Portage
Hull, Quebec K1A 1K8
Facsimile 819-953-7876

Supporting Information

The table below indicates the location of CER supporting documentation in this emergency response plan.

Supporting Information	Found in
CER Distribution	Foreword: Distribution List Page 3
Company 24/7 Emergency Number	Area Specific Information: Binder Cover
Area Map of CER Regulated Facilities	Area Specific Information
TSB Roles & Responsibilities	Section 5: External Agencies Federal Roles Chart
CER Roles & Responsibilities	Section 5: External Agencies Federal Roles Chart
Safety data sheets (SDS)	Area Specific Information
Health and Safety Plan	Please refer to the company’s Health & Safety Plan located at the corporate head office.



Emergency Preparedness & Response Policy

Emergency Management Expectations

An effective emergency management program includes being prepared for emergencies, responding in the event of an emergency and ensuring that operations are able to continue safely and can recover in a timely, efficient manner.

Emergency management is critical to ensuring that people, the environment, the public, the organization's assets and reputation are protected in the event of an unanticipated hazard event, be it natural, technological or human-induced.

Emergency Management Preparedness

Emergency preparedness is a continuous process of all-hazards planning and coordination in order to effectively minimize the adverse effects and consequences inherent in any emergency incident. Through the use of such tools as exercises, proactive resource management and capability analysis, preparedness is one of the key pillars with which to ensure the adaptation of comprehensive approaches for the company's emergency management strategy. The emergency management process must include the following:

- Hazard Risk and Vulnerability Assessment
- Public Involvement
- Communications Planning
- Situational Awareness
- Crisis Management Plans
- Emergency Response Plans
- Emergency Management Resources
- Competence, Training and Awareness
- Exercises and Drills
- Record Keeping
- Distributions Lists (Internal and External)
- Continuous Improvement

Emergency Response Plans should contain:

- Communication procedures
- Emergency contacts
- Evacuation and Rescue plans
- Equipment locations and supply companies
- Spill response and containment (where required)
- Meet regulatory requirements
- Event classification
- Activation and Stand Down Levels
- Guidelines for medical emergencies
- Defined roles and responsibilities
- Maps and Emergency Planning Zones
- Mutual Aid Understandings (where applicable)

Confidential ERPs will be available at the field Incident Command Post and the Corporate Emergency Response Centre.



Extended Emergencies

In an extended emergency, company responders will develop an Incident Action Plan utilizing forms found within ERP, which may include:

- ICS Form 201 – Incident Briefing
- ICS Form 202 – Incident Objectives
- Form A1 – Initial Emergency Report
- Form A4 – Incident Action Plan (IAP) Checklist

Emergency Response, Continuity and Recovery

In the event of an emergency, each business unit shall determine the level of emergency as per established protocols and respond according to their respective emergency response plans. Response includes the mobilization and ongoing management of resources, people, equipment and assets to manage the effects of an incident; functions inclusive of the Incident Command System (ICS), the company's primary response platform.

Each business unit shall establish, implement and maintain procedures for communicating information related to emergency management, including:

- Communication of plans and procedures to employees, operating partners, contractors, the supply chain, regulators and local communities; and
- Emergency and crisis communications to stakeholders, including emergency responders, regulators, the media, family members and the public.

Emergency Management Monitoring, Assessment and Continuous Improvement

Lessons learned and knowledge generated from monitoring results should be used to develop "improved practices", which are then shared widely. After emergencies or disasters occur, a systematic approach is used to learn lessons from the experience, increase effectiveness and improve emergency management practices and processes.

Manual Updating Procedures and Schedule

The company's Corporate and Site-Specific ERPs are to be updated annually and submitted to the CER on or before April 1st of each year, or when significant changes (either operational or identified from exercises/incidents and resulting debriefs) occur or are identified. If an update occurs outside of the January 1st to April 1st period, a letter must be submitted to the CER indicating that there have been no changes to operations since the ERP was last submitted. ERP updates are performed by a third-party company (H2Safety), whose expertise in the field provides company personnel with the education, training, and resources to excel in Emergency Response. Approvals for ERP updates will be carried out by the company's Emergency Management Coordinator.



Debriefing

Internal Debriefing

The Incident Commander, in consultation with the Lead Agency and/or other regulatory body, will order "Return to Normal" status.

- All response team members and on-site personnel, including contract personnel and emergency services, will be notified.
- All previous contacts including public, workers, landowners, government and industrial operators must also be notified of the end of the emergency.
- Ensure a media statement is prepared and delivered by Senior Management.
- Debriefing meeting(s) with company personnel (including insurance, legal, and human resources as appropriate) must be conducted.
- Debriefing meeting(s) to review effectiveness of the Emergency Response Plan must be conducted. Feedback and comments as a result of the debrief must be incorporated into the ERP revision and procedures. This feedback should be submitted to the ERP provider.
- Debriefing meeting(s) with residents, landowners, Lead Agency and other government agencies and all other impacted parties may be conducted.
- Document all "Return to Normal" activities.
- Complete response debriefing for all response teams. Submit, in writing, response findings and recommendations to the Incident Commander when applicable, which will be submitted to the overall report writer.

Public Debriefing

When the public has been impacted, company operations should provide the public information as soon after the emergency as possible, to answer any questions or concerns. This should be done by a senior company representative, a trained Media Advisor, or by the Incident Commander.

After an emergency, a number of additional items should be considered:

- Debriefings, as mentioned above.
- Crisis management for company personnel and for other members of the public that may have been significantly affected by the emergency.
- If the emergency is of a level where it has impacted the public, an information center may be established within the community where the emergency occurred to answer any questions posed by the public.
- Establish a means of compensating citizens who may have had out-of-pocket expenses (such as meals and lodging costs) as a result of the emergency.
- Through the media, provide details of the investigation into the incident that are pertinent to the public, as it becomes available.

Health and Safety Plan

The company's extensive Health and Safety program is to be implemented at all times during and after an incident. Training is provided to all company employees and contractors; all information and documentation can be found in the Health and Safety Manual.

Site Specific Control Points and Response

In the event of an incident (reported from an external source and/or confirmed by a drop in pressure), an operator would be sent out to visually confirm the need to shut down operations. Operators have the ability to manually trip the ESDs at the risers on the CER line. The operator would then immediately contact his/her supervisor and the TSB, and then work with internal support and outside agencies to determine a plan of action for resolving the source of the release.